

Application System/400™

SC41-9755-00

**Programming:
System/38 Environment
Programmer's Guide and Reference**

Version 2

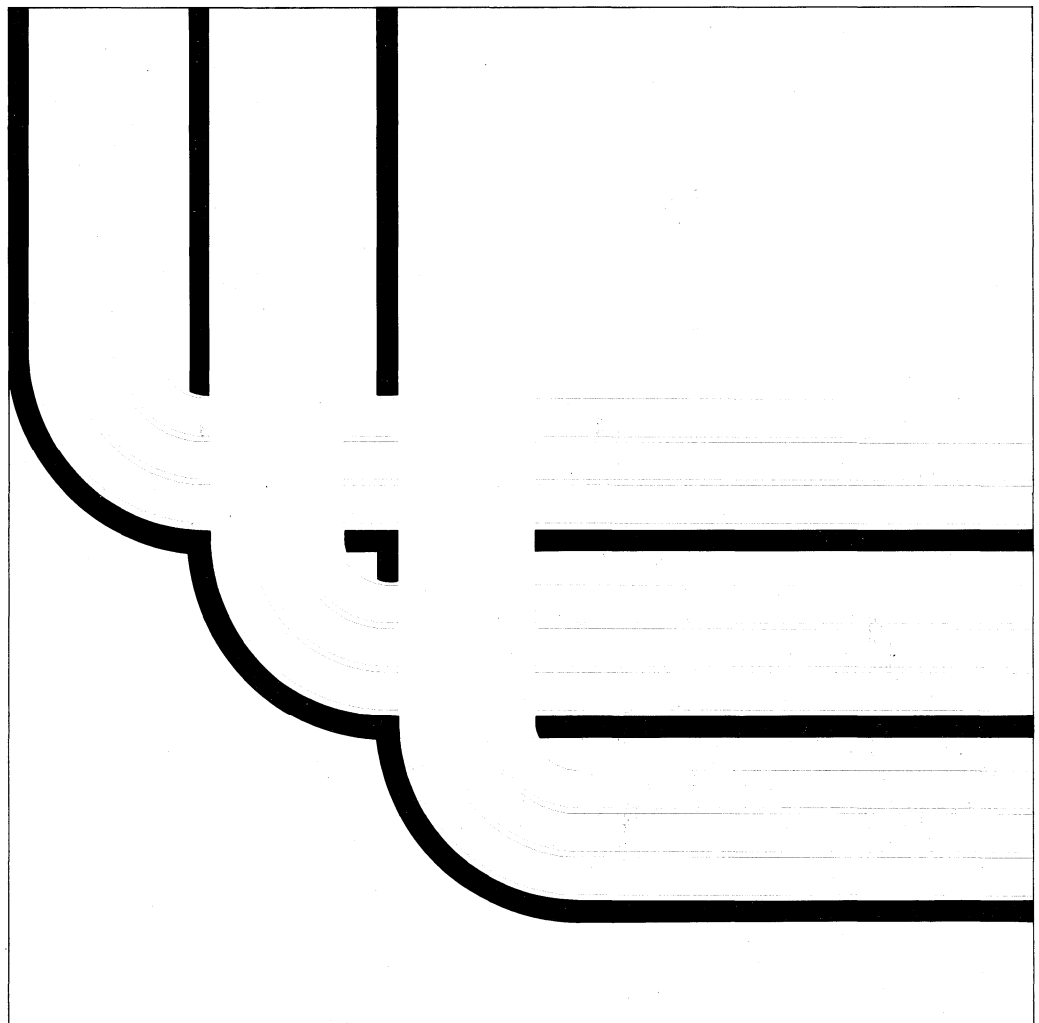

System and Application Support

Take Note!

Before using this information and the product it supports, be sure to read the general information under "Notices" on page v.

First Edition (May 1991)

This edition applies to the licensed program IBM Operating System/400, (Program 5738-SS1), Version 2 Release 1 Modification 0, and to all subsequent releases and modifications until otherwise indicated in new editions. Make sure you are using the proper edition for the level of the product.

Order publications through your IBM representative or the IBM branch serving your locality. Publications are not stocked at the address given below.

A form for readers' comments is provided at the back of this publication. If the form has been removed, you may address your comments to:

Attn Department 245
IBM Corporation
3605 Highway 52 N
Rochester, MN 55901-7899

When you send information to IBM, you grant IBM a non-exclusive right to use or distribute the information in any way it believes appropriate without incurring any obligation to you or restricting your use of it.

© Copyright International Business Machines Corporation 1991. All rights reserved.

Note to U.S. Government Users — Documentation related to restricted rights — Use, duplication or disclosure is subject to restrictions set forth in GSA ADP Schedule Contract with IBM Corp.

Contents

Notices	v	APPC
Programming Interface	v	Pass-Throu
About This Manual	vii	Object Distr
What the Manual Contains	vii	SNADS
What the Manual Does Not Contain	vii	Interchangi
Who Should Use This Manual	vii	Mixed File
		Interchangi
		Alerts
		Interchangi
		Interchangi
Chapter 1. Migration to the System/38		Chapter 6.
Environment	1-1	Applicatio
Operational Differences	1-1	Automating
The Migration Aid	1-2	List by Func
Moving Objects without the Migration Aid	1-2	APF
Restoring the System/38 Objects on the		CL
AS/400 System	1-3	CL Progr
Significant Changes	1-3	Comman
How the System/38 Environment Is Defined	1-5	Commitn
What Is the System/38 Environment?	1-6	Data Des
How Should You Operate the System?	1-10	Database
Object Attributes and Source Types	1-10	Message
Example	1-14	Program
Migrating Multiple System/38s to a Single		Return C
AS/400 System	1-15	Languag
		COBOL
		Report P
Chapter 2. Changes Needed after Migration	2-1	Chapter 7.
Operating System/400 Program	2-1	What You S
Utilities and Other Licensed Programs	2-61	You Migr
Languages	2-65	Before Res
		Migration o
		Handling
		What Shoul
Chapter 3. Converting from the System/38		Appendix A
Environment to the OS/400 Program	3-1	Command
Overview	3-1	Command I
CL Programs and Job Streams	3-1	Appendix B
Files and Data Management Changes	3-3	Appendix C
Languages	3-5	Codes
Data File Utility (DFU)	3-5	Major and I
Query	3-5	(Display a
Mass Changes of Source Types	3-5	Appendix D
Chapter 4. Changes Needed to Convert to		1. Print Dev
the OS/400 Program	4-1	
General	4-1	
Operating System/400 Program	4-1	
Utilities and Other Program Products	4-16	
Languages	4-17	
Chapter 5. Coexistence with an AS/400		
System	5-1	
Interchanging Media	5-1	
Interchanging Save File Data	5-1	
Exchange ID	5-1	

From One Library to Another	D-3 D-7	Converting to AS/400 System	E-2
Getting from AS/400 System	E-1	Glossary	G-1
		Bibliography	H-1
		Index	X-1

Notices

References in this publication to IBM products, programs, or services do not imply that IBM intends to make these available in all countries in which IBM operates.

Any reference to an IBM licensed program or other IBM product in this publication is not intended to state or imply that only IBM's program or other product may be used.

IBM may have patents or pending patent applications covering subject matter in this document. The furnishing of this document does not give you any license to these patents. You can send license inquiries, in writing, to the IBM Director of Commercial Relations, IBM Corporation, Purchase, NY 10577.

The following terms, denoted by an asterisk (*) in this publication, are trademarks of the IBM Corporation in the United States and/or other countries:

Application System/400	AS/400
IBM	NetView
Operating System/400	OS/400
Personal System/2	PROFS
PS/2	RPG/400
SAA	SQL/400
System/370	Systems Application Architecture
400	

This publication could contain technical inaccuracies or typographical errors.

This manual may refer to products that are announced but are not yet available.

This publication contains examples of data and reports used in daily business operations. To illustrate them as completely as possible, the examples include the names of individuals, companies, brands, and products. All of these names are fictitious and any similarity to the names and addresses used by an actual business enterprise is entirely coincidental.

This manual contains small programs that are furnished by IBM as simple examples to provide an illustration. These examples have not been thoroughly tested under all conditions. IBM, therefore, cannot guarantee or imply reliability, serviceability, or function of these programs. All programs contained herein are provided to you "AS IS". THE IMPLIED WARRANTIES OF MERCHANTABILITY AND FITNESS FOR A PARTICULAR PURPOSE ARE EXPRESSLY DISCLAIMED.

Programming Interface

The *System/38 Environment Programmer's Guide/Reference* discusses migration from the System/38 to the OS/400 System/38 environment, conversion to the OS/400 program, and coexistence with the AS/400 system. This manual contains no programming interfaces for customers.

About This Manual

What the Manual Contains

This manual discusses the implications inherent to migration from a System/38 to the OS/400 System/38 environment, conversion from the System/38 environment to the OS/400 program, and coexistence with the AS/400 system.

- Migration to the System/38 environment

Once you have migrated to the System/38 environment, these items need to be addressed:

- Documentation of changes from System/38

Changes exist between the AS/400 system and System/38. Some of the changes are due to hardware differences and some provide an easier to use and more consistent system. An overview is provided in Chapter 1 and further details are described in Chapter 2.

- Migration Aid

The Migration Aid assists in the migration from System/38 to the AS/400 system. An overview is presented in Chapter 1.

- System/38 environment

This is special support on the AS/400 system that allows you to run most of your System/38 applications unchanged. The System/38 environment and recommendations for its operation are described in Chapter 1.

- Conversion from the System/38 environment to the OS/400 program

The System/38 environment allows you to operate on the AS/400 system, but you cannot effectively use many of the new AS/400 system functions. Chapter 3 describes how to convert your applications to the OS/400 program. Chapter 4 provides the details of the changes to consider and some of the new functions you can use in converting to the OS/400 program.

- Coexistence with the AS/400 system

Coexistence means an AS/400 system and another system can operate together either by interchanging media or by a communications line. Two forms of coexistence should be considered:

- Communications and interchange with an AS/400 system

For example, you might need to send data from a System/38 to an AS/400 system or vice versa. You might want to exchange media or be tied together through a communications line. If you replace a System/38 with an AS/400 system, the systems you are communicating with might need to make some changes. The considerations for interchange are discussed in Chapter 5.

- Maintaining source code for System/38

For example, assume you have both a System/38 and an AS/400 system and want to maintain applications for both. The OS/400 program allows you to write and develop the System/38 applications on the AS/400 system. Chapter 6 addresses the maintaining of these applications.

What the Manual Does Not Contain

You may need to refer to other IBM manuals for more specific information about a particular topic. The *Publications Guide*, GC41-9678, provides information on all the manuals in the AS/400 library.

For a list of related publications, see the "Bibliography" on page H-1.

Who Should Use This Manual

The information in this manual is directed at users who want to maintain the System/38 applications on the AS/400 system, users who have completed the migration using the Migration Aid and are converting objects to operate in the Operating System/400 (OS/400) System/38 environment, and systems operators who are oper-

| ating in a coexistence mode with the AS/400
| system.

| In regard to the OS/400 System/38 environment,
| you should be familiar with the following
| System/38 operational considerations:

- | • Existing devices and their configurations
- | • File structures and relationships
- | • Existing libraries and associated objects
- | • Programs to be modified
- | • Data files and documents affected

- | • Basic System/38 commands
- | • Security procedures and functions
- | • System structure and related utilities

| If you plan to operate in a coexistence mode or
| to maintain the System/38 applications, you
| should be familiar with the communications
| requirements of your system and the required
| objects. Based on information presented in this
| manual, you may need to make changes to
| associated files, procedures, and objects.

Chapter 1. Migration to the System/38 Environment

To assist in the migration, the AS/400* system supports the System/38 environment, which allows you to run most of your existing programs without change. The System/38 environment provides:

- Easy transition from System/38 to the new AS/400 system
- Interchange of the System/38 applications with new AS/400 system functions
- Maintenance of the System/38 applications on the AS/400 system

This chapter provides an overview of the OS/400* System/38 environment and functional considerations for operating in it. Major differences between the System/38 and the System/38 environment include:

Hardware differences: The processing unit and some of the attached devices differ between System/38 and the AS/400 system.

Operational differences: Operational differences are the result of such things as hardware differences, changes for consistency, changes for ease of use, or changes caused by a different command syntax.

Programming differences: Some programming differences are caused by hardware differences. The primary place for change is in the applications used to operate and manage the system (for example, save and restore). Most end user applications will see few, if any, changes. The major changes are described in this chapter and further details are in Chapter 2.

Operational Differences

You can use the System/38 environment to run most programs that were written for System/38.

The major differences between the System/38 environment and the AS/400 system are:

Syntax change: The syntax for a qualified name differs as follows:

System/38 environment	CALL	PGM(PGMX.LIBY)
OS/400	CALL	PGM(LIBY/PGMX)

The AS/400 system support is designed to allow for conversion of both System/38 and System/36. System/36 allows a period within an object name. To enable a conversion of the System/36 objects, a period is valid in the AS/400 system names. This requires that a new syntactical character '/' be used as a separator (slash instead of period).

Note that only the qualified name syntax differs. If you use an unqualified name, the syntax looks identical.

System/38 environment	CALL	PGM(PGMX)
OS/400	CALL	PGM(PGMX)

Command name changes: Several command names have been changed to provide for better consistency between systems (such as, the use of verbs like STR and END). (See Appendix A for a complete list.) Some of the changes include:

System/38 Environment	AS/400 System
CNLJOB	ENDJOB
CNLSPLF	DLTSPLF
EDT SRC	STRSEU
ENTDBG	STRDBG
RPLLIBL	CHGLIBL
STPCTLR CY	ENDCTLR CY
TRMSBS	ENDSBS

Keyword changes: In some cases, keywords on the System/38 commands have been dropped or parameter values have been changed. For example, the PWRDWN SYS ADRRGN parameter has been dropped because address regeneration is no longer needed. For most commands, the System/38 environment allows these dropped parameters to be specified, but they are ignored if the command is run.

Default changes: In some cases, command parameters have different default values. For example, on SBMJOB, the default for the INLLIBL parameter on the OS/400 program is *CURRENT, instead of *JOB D in the System/38 environment.

Commands supported only in the System/38 environment: For example, the IDU Query and data file utility (DFU) functions from System/38 are supported only in the System/38 environ-

ment. New AS/400 functions are similar to the functions provided by Query and DFU on System/38.

New functions: Command help information is only available for OS/400 commands. New commands and functions exist that are only available on the OS/400 program.

The Migration Aid

Transferring files and objects to the AS/400 system is made easier through the use of the Migration Aid. A brief description of its functions and features is included to provide users maintaining the System/38 applications on the AS/400 system and users operating in a coexistence mode an understanding of the migration tasks performed by this utility.

The Migration Aid assists in migrating your System/38 objects to the AS/400 system. Part of the utility operates on System/38 and part on the AS/400 system. You are able to migrate one or more libraries at a time or individual objects. Audit trail, summaries, and exception reports are provided.

The System/38 Migration Aid identifies functions that do not operate on the AS/400 system. These functions must be reviewed and changed before you can successfully operate in the System/38 environment.

The Migration Aid assists in converting your device configuration (this includes device, controller, and line descriptions) and user profiles. For the majority of your objects, the Migration Aid runs a save operation from System/38 and a restore operation on the AS/400 system. To migrate a program object, the program must include the program template. See "Save and Restore" on page 2-35 for a complete discussion of the program template. The Migration Aid assists in identifying a library's nonobservable programs; that is, those programs that do not have a template. If the program template has been removed, the source must be used on OS/400 to re-create the program. System/38 PASCAL programs must always be re-created from the source.

The device configuration objects saved by the Migration Aid are restored on the AS/400 system

using the Migration Aid. The utility maps the configuration objects into the new AS/400 internal format. The device configurations for unsupported devices (for example, the diskette magazine device) are ignored by the Migration Aid.

The definition of how security authorizations operate has changed from System/38 to the AS/400 system. The Migration Aid migrates the authorizations from the System/38 version to minimize the changes you need to consider. This special migration function is only available with the Migration Aid. See "Security" on page 2-36.

In addition, the Migration Aid migrates the Personal Services/38 objects (except for group calendars).

However, the Migration Aid does not migrate all objects from System/38. You need to make a manual conversion of such things as:

- Some system values
- Network attributes
- Job accounting journal
- System network architecture distribution services (SNADS) configuration
- User auxiliary storage pools (ASPs)
- Checksums

The Migration Aid does not identify every difference between System/38 and the System/38 environment. Some operational differences (for example, different function keys are used) are only seen when they are used interactively. In addition, you might need to scan some of your source and objects to look for specifics described in Chapter 2.

The Migration Aid does not migrate the IBM licensed programs. AS/400 licensed programs must be installed on the AS/400 system.

See the *System/38 to AS/400 Migration Aid User's Guide and Reference* for details.

Moving Objects without the Migration Aid

The Migration Aid assists in identifying the functions not supported on the AS/400 system. Some of this can also be determined using this manual and scanning your source and objects.

The Migration Aid provides important assistance for migrating security and device configurations and Personal Services/38 objects. With these exceptions, the major function performed is a save operation on System/38 and a restore operation on the AS/400 system.

You cannot do a hardware transfer of the disk units and use the information that was on the System/38 disk units. You can use the 9332 or the 9335 Disk Units on the AS/400 system, but you must do a save on System/38, initialize the disk units, and then use the restore command on the AS/400 system.

The restore function on the AS/400 system converts the objects saved from a System/38 save command (for example, SAVLIB).

Program objects can be restored only if they include the program template. See "Save and Restore" on page 2-35 for a complete discussion of the program template.

Tape media written from a SAVSYS operation on System/38 can be used to restore user profiles, but authorities (see "Security" on page 2-36) are not converted. The device configuration and authorities information can be migrated only using the Migration Aid functions on both System/38 and the AS/400 system.

You must be careful in restoring the library QGPL saved from System/38 because you will overlay the shipped AS/400 defaults. Instead, you should restore only selected objects with the RSTOBJ command or restore your System/38 QGPL library into another library on the AS/400 system. You should not restore the library QUSRSYS. See the recommendations in Chapter 7.

Restoring the System/38 Objects on the AS/400 System

When System/38 objects are restored on the AS/400 system, some changes occur. (See Chapter 2 for details.)

Programs must include the program template and are converted to a new internal format (see "Save and Restore" on page 2-35).

Database access paths that were saved from System/38 are restored (not rebuilt), assuming the requirements for restoring access paths are met. These are essentially the same requirements that exist on System/38 for restoring access paths. The *Backup and Recovery Guide* contains these requirements in the chapter that discusses the save and restore operations.

Significant Changes

The following are the major differences between System/38 and the System/38 environment, which gives you an idea of the types of changes needed to successfully migrate to the System/38 environment. A more detailed explanation of these differences and others is given in Chapter 2.

Hardware differences: See the *Migrating from System/38 Planning Guide* for a list of the supported devices. Some of the major devices and differences are also discussed in this section. The following hardware differences must also be considered:

- The 62PC internal drive and the 3370 external drives are not supported. The 9332 and 9335 Disk Units are supported.
- The 3410 and 3411 tape devices that attach to System/38 are not supported.
- The System/38 console device does not exist. A work station device (it need not be dedicated) must be used as the console.
- The hardware control panel differs significantly.
- The diskette magazine device is not supported. A single-slot diskette device is optionally available.
- System-attached printers are not supported. Only work station printers are supported.
- The 5251 Model 1 and Model 2 (12-by-80 display stations) are not supported.
- The 5252 (dual display station) is not supported.
- The double-byte character set (DBCS) Printers 5224 Model 12 and 5225 Models 11 and 12 are not supported.
- Basic uninterruptible power supply (UPS) is supported but not as defined in the

System/38 Uninterruptible Power Supply Planning Guide. The full UPS is still supported, but the approach has been changed.

- The PC Support/400 product does not support:
 - Attachment through the 5294 remote controller. The 5394 remote controller must be used.
 - Asynchronous attachment through the 5208 or through the RolmBridge. A direct attachment to the asynchronous controller must be used.

For details of PC Support/400 see the manual *PC Support/400 DOS Installation and Administration Guide*.

- The 5424 card device is not supported.
- The RPQ for the System/370* channel is not supported.
- The 56Kb DDSA line is not supported.

Operational changes: These changes do not necessarily affect programs, but may require some retraining.

- Hardware-related changes exist (such as those due to the new operator control panel and new tape units).
- System displays and printed output have been changed. Most of the system displays adhere to the Systems Application Architecture* guidelines for Common User Access (CUA). Command keys have been redefined. Many displays allow for the entry of commands and parameters.
- System menus exist to assist with operating the system.
- The command prompter has been changed to allow easier entry of parameters. For complex commands, a small number of parameters are shown first, and the values entered are used to determine which of the other parameters are shown.
- The service aspects of the system have significantly changed. More functions are available to assist, you such as diagnosing problems, communicating with IBM, and receiving programming changes.
- IBM-supplied message text has been changed.

- Some commands have different defaults. For example, the SBMJOB command in the System/38 environment uses the RTGDTA parameter as a default to QCMD38 instead of *JOBID.
- Several functions default to simplify system operations for a small configuration with a small number of end users. To achieve System/38 compatibility, you need to change certain defaults. For example, the system is shipped at a security level that allows a sign-on without a password.
- If password protection is desired, the two-level sign-on (both user name and password) is the only method supported. The single-level sign-on option (password only) is not supported.
- The CSNAP commands on System/38 are not supported.

Programming changes: Significant programming changes that must be considered include:

- Programming changes related to hardware changes. For example, the optional diskette device supports only a single slot instead of multiples, and no system printers exist. Therefore, print images and the CLNPRT command have no meaning.
- Programming changes related to operational changes. For example, if you have programs that use CPYSPLF to copy the output of system printed output to database files, the format of the printed output has been changed in many cases.
- The CRT and CHG device configuration commands have been totally replaced. The System/38 commands do not work even in the System/38 environment.
- Neither the System/38 Text Management licensed program nor the editor from Personal Services/38 is supported. AS/400 Text Management/38 is available to allow most of these same functions. The documents created using any of the text functions can be migrated to OfficeVision/400 documents with some changes made in the document and in the method of working with the document.

For information on the differences between System/38 Text Management and OfficeVision/400, see "Text Management

5714-WP2” on page 2-65 and the *Using OfficeVision/400* Word Processing*. For more information on migrating documents to OfficeVision/400, see the *System/38 to AS/400 Migration Aid User's Guide and Reference*.

- All personal computers and PS/2*s using PC Support/400 must be upgraded to DOS level 3.3 or higher.
- Deletions and changes have been made to system values and network attributes. Some of these are not migrated by the Migration Aid. See the *System/38 to AS/400 Migration Aid User's Guide and Reference* for a sample program that can be used as a model for moving these values to the new system. Those that are not migrated must be manually reentered on the AS/400 system.
- Some programming changes are due to security changes. A change has been made in how authorizations are processed (see “Security” on page 2-36).
- The defaults for SBMJOB have changed for both the System/38 and the OS/400 programs (see “Work Management” on page 2-60).

How the System/38 Environment Is Defined

The System/38 environment is implemented as an attribute of a program or a file. If you run a program that has the System/38 environment attribute, the program uses System/38 command syntax, command definitions, and function.

When System/38 objects are restored on the AS/400 system, some are marked as a System/38 environment object. You can enter the System/38 syntax using the source entry utility (SEU). You can create the System/38 environment objects on the AS/400 system.

You can run both the System/38 environment and OS/400 programs in any combination.

OS/400 PGMA

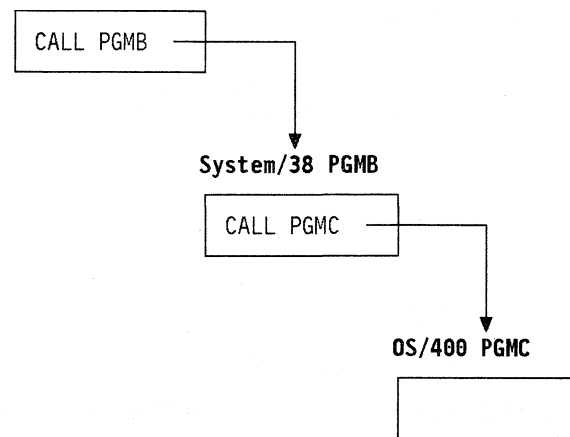

You can use file types from either System/38 or the AS/400 system while a program is running. For example, an OS/400 or a System/38 program can access a System/38 environment file, an OS/400 file, or both.

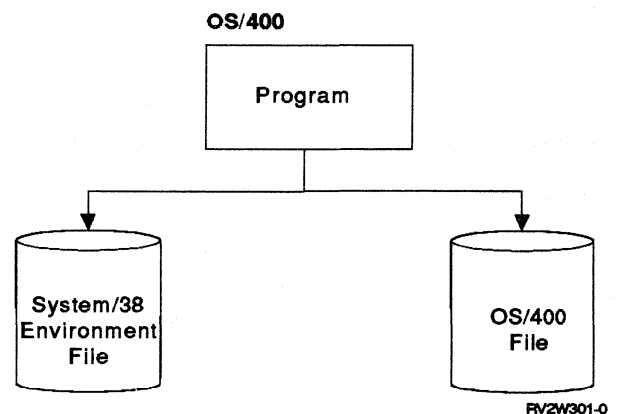

When you operate from a command entry display or the Programmer Menu on System/38, you are entering data to a program. In most cases, this data is in the form of a command. The same is true when you submit a batch job. The command becomes input data to a routing step program.

You cannot pass data in the form of a command to an application program unless it has been specifically written to process commands. If you write a program to process commands, the program must be specifically written to adhere to the syntax rules required (for example, required keywords, or how qualified names are specified). System/38 environment and OS/400 command-processing programs operate with a similar approach. You must ensure that you are

entering the data in the proper syntax for a System/38 environment program as opposed to an OS/400 program.

The Programmer Menu (QPGMMENU) does not have a System/38 environment version. You can request to operate on System/38 type source and create System/38 environment objects. However, when you enter a command on the command line, it must use OS/400 syntax. The new programming development manager also accepts only OS/400 syntax.

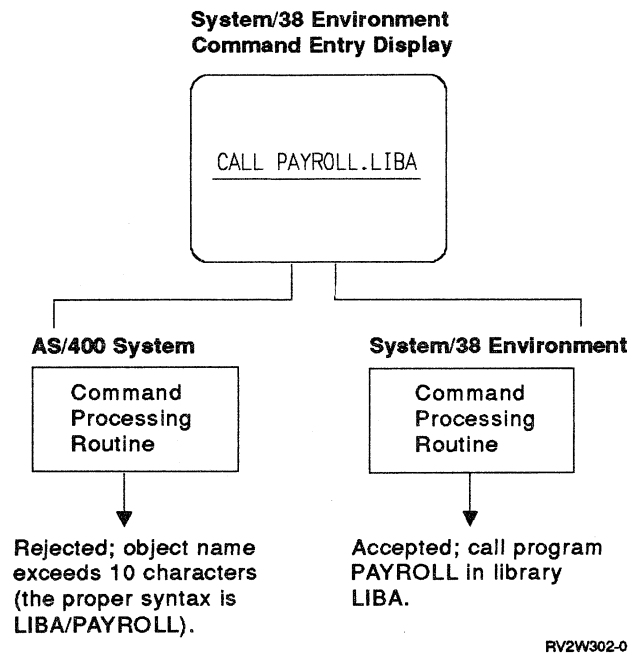

RV2W302-0

Duplicate IBM programs exist so that commands can be entered in either syntax. For example:

System/38 Environment	AS/400 System
QCL	QCMD
QCAEXEC	QCMDEXC
QCACHECK	QCMDCHK
--	QPGMMENU

What Is the System/38 Environment?

The System/38 environment commands are shipped in library QSYS38, while OS/400 commands are shipped in library QSYS. The QSYS38 library contains IBM command definitions for all of the System/38 environment capabilities and not just System/38 Control Program Facility (CPF) commands. For example, the System/38 environment command CRTRPGPGM is in QSYS38 and not in the QRPG library.

Consider the DLTPGM command. It has a command definition object in both QSYS38 and QSYS. Both commands use the same command processing program, which is in QSYS. The TRMSBS command definition object is in QSYS38, but the command in the OS/400 program has been renamed to ENDSBS, which is in QSYS. Both command definitions use the same command processing program that is in QSYS.

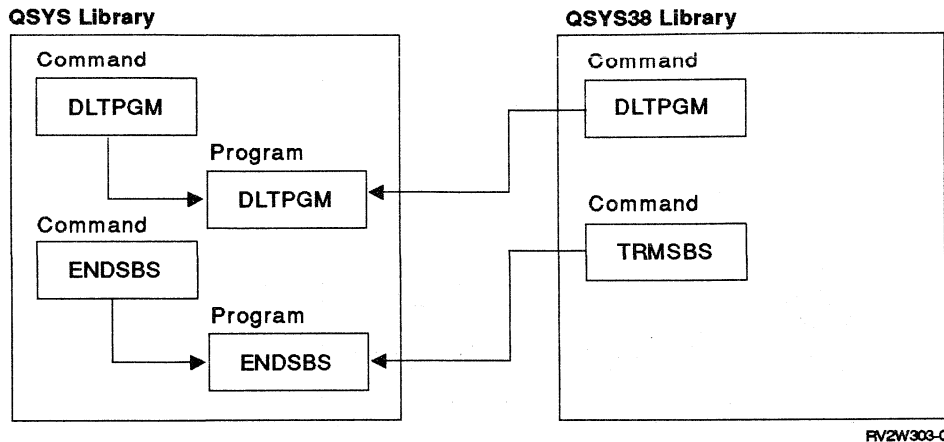

The attribute (the AS/400 system or the System/38 environment) of the running program is passed to the command analyzer. This tells the command analyzer how to map the parameters so the same command processing program can be used. For example, if you say:

```
System/38 environment  DLTPGM  PGM(PGMX.LIBY)
OS/400                 DLTPGM  PGM(LIBY/PGMX)
```

The command analyzer converts the parameter data so that the command processing program sees a common value of:

```
'PGMX      LIBY      '
```

The command definition statements appear the same for a qualified name (for example, the QUAL statements occur in the same order). For more information on command definition statements, see "Command Definition" on page 2-2.

The command help function presents the qualified names in the sequence of the command definition QUAL specifications. Consequently, the qualified name is shown on the prompter as:

```
Program to be deleted . . . _____
Library name . . . . . *LIBL _____
```

If you are typing information into the SEU, the type of source you are entering (System/38 or OS/400 program) determines the form in which the data is passed back to SEU from the prompter. There are different source types for the OS/400 program (for example, source type

CLP) and the System/38 environment (for example, CLP38).

Qualified names in the form of FIELD.FILE are also used on System/38 (for example, the OPNQRYF command). This syntax has also been changed to FILE/FIELD.

If you have replaced some of the IBM commands with your own version, you need to use the QUSER38 library. You should place your own version of the IBM System/38 commands in the QUSER38 library (see also "Command Definition" on page 2-2).

If you run a program with the System/38 environment attribute (or operate from a System/38 command entry function), the system attempts to find the command definition first in the QUSER38 library. If it does not exist, it checks the QSYS38 library. If the command cannot be found in either the QUSER38 or QSYS38 libraries, the library list (including QSYS) is used.

On System/38, if you wanted to replace the IBM version of the DLTPGM command, you placed the command in a specific library and changed the system library list so your version would be found. Neither the QUSER38 nor QSYS38 library should be in the job's library list. Only QSYS38 is shipped by the system. You must create QUSER38 if you require it. On the AS/400 system, you place the commands you need in the QUSER38 library and do not change the library list. If the command cannot be found in either of these libraries, the library list (including QSYS) is used.

System/38 Approach

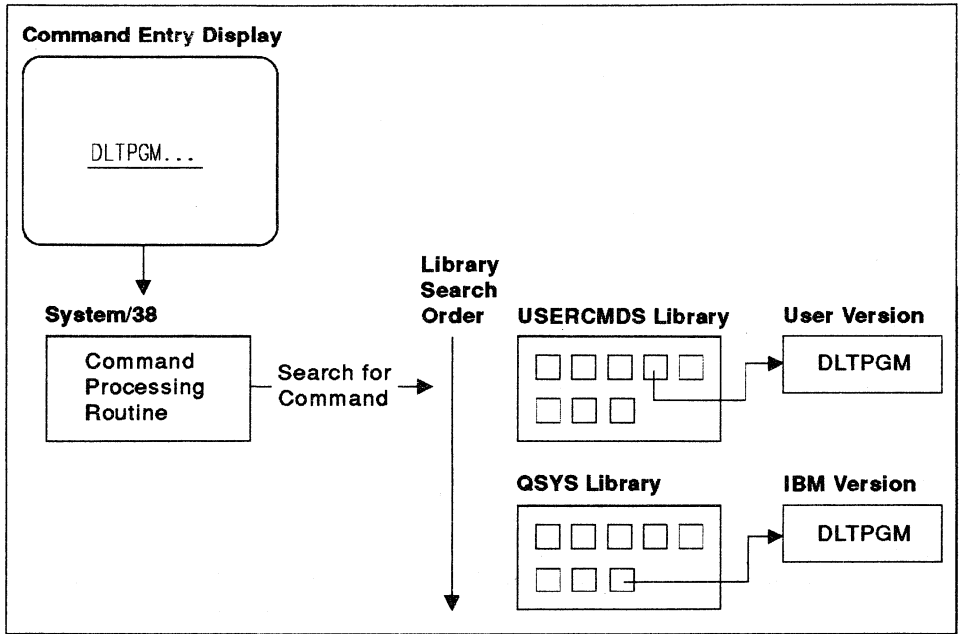

System/38 Environment Approach

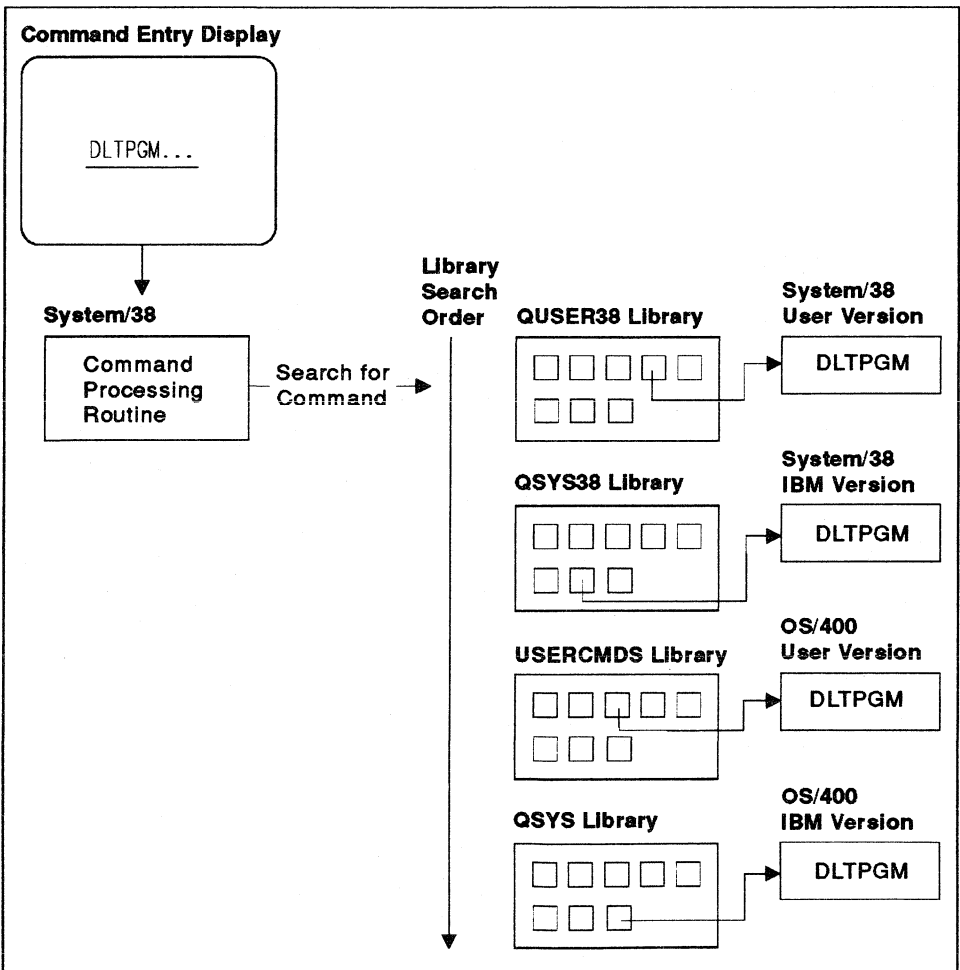

RV2W304-0

Figure 1-1. Command Processing on System/38 and in the System/38 Environment

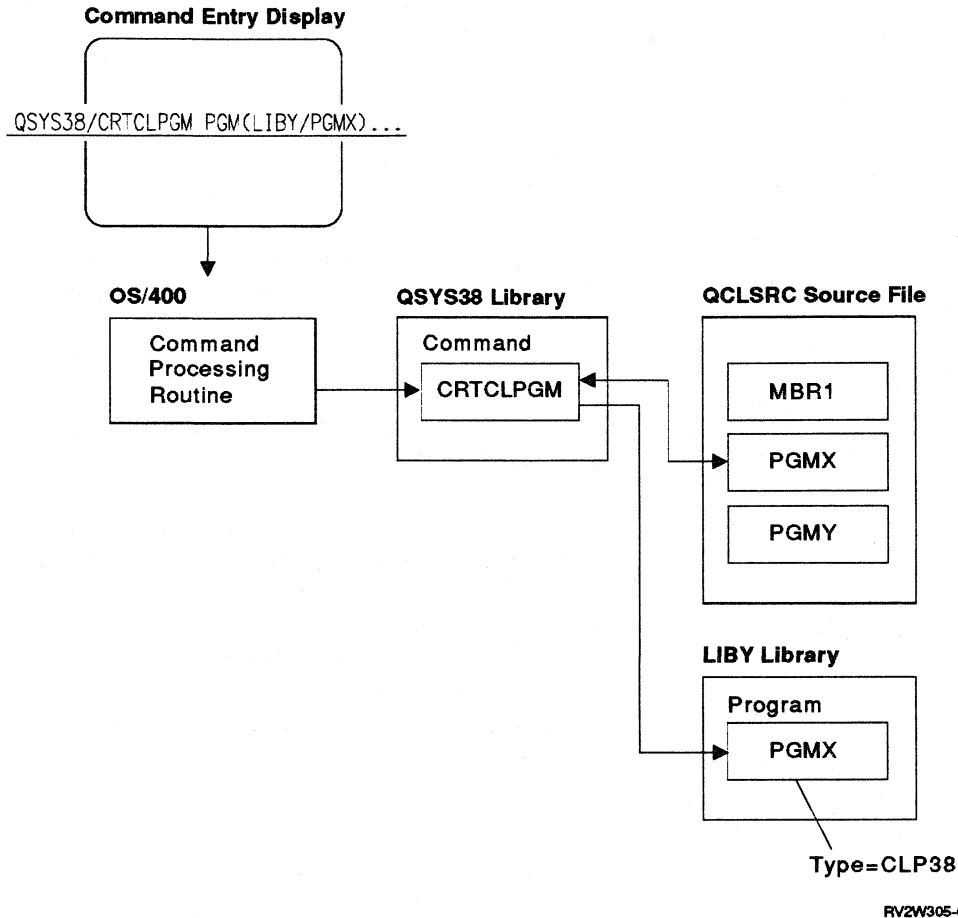

Figure 1-2. Creating a System/38 Program from the OS/400 Command Entry Display

The QSYS38 and QUSER38 libraries should not be in the library list. They are implicitly searched first by use of the System/38 environment when searching for the command.

Thus, it is possible within a System/38 environment program to use a mixture of:

- User versions of the System/38 environment commands
- System/38 environment commands
- User versions of OS/400 commands
- OS/400 commands
- User commands

Note: Even if the command is only an OS/400 command and never existed on System/38, you must still enter it in System/38 syntax (OBJ.LIB) if it is used in a System/38 environment program.

You can also enter a System/38 command into an OS/400 program using the library qualifier. You must enter the command using OS/400

syntax. For example, assume you are operating on the OS/400 Command Entry display and want to create a System/38 environment CL program. Using the CRTCLPGM command in QSYS38 causes the program to be marked as a System/38 environment program.

If you are operating in the OS/400 program or writing an OS/400 program, most IBM commands perform an identical function and, therefore, you do not need to qualify them with a specific library. Some functions (for example, System/38 Query and DFU) exist only in the System/38 environment. Commands for these functions must be library qualified if they are used in an OS/400 CL program such as:

```
QSYS38/CHGDTA ...
```

If you want to interactively enter commands using the System/38 syntax, you need to call the QCL program.

```
CALL QCL
```

The QCL program is actually located in QSYS so you do not need to use a library name. Then you enter the System/38 syntax such as:

```
CRTCLPGM PGM(PGMX.LIBY)
```

The System/38 environment support for searching QSYS38 is limited to determining which command to process. For example, if you specified the following in a System/38 environment program, the DSPOBJD command would be found in QSYS38:

```
DSPOBJD OBJ(*ALL.*LIBL) OBJTYPE(*CMD)
```

When the command runs, it uses the library list to find all the commands. Because QSYS38 is not on the library list, none of the System/38 environment commands would be found.

How Should You Operate the System?

The System/38 environment does not provide a complete system environment. You cannot totally ignore the OS/400 program. You will see only OS/400 versions of such functions as displays and messages.

The displays that allow commands to be entered (for example, the Programmer Menu) or parameters to be entered for list displays (for example, DSPOUTQ) allow only OS/400 syntax. In addition, you cannot use the new functions supplied by the OS/400 program unless you become familiar with such things as the new syntax and command names. Command entry functions should be done in the OS/400 program.

Attempting to operate solely as you did on System/38 is feasible only to a degree. If you attempt to switch back and forth between the System/38 environment command entry and the OS/400 environment command entry, you can become confused. Because the syntax, some of the command names, and some of the function keys differ, it is not desirable to switch frequently.

This manual assumes that you are operating the system using OS/400 support. You will probably have to run and maintain programs and files that were written for System/38. You will want to convert, over time, your System/38 environment objects to the OS/400 program. The more objects you convert to the OS/400 program, the

less you will have to be concerned with different processes for entering the syntax and spelling the commands.

You may also have a need to coexist with another System/38. The AS/400 system can be used to prepare source and to test. In doing this, you will have to switch thought processes from an OS/400 approach to the System/38 environment. However, you can stay in the OS/400 environment and only use the System/38 syntax when you are operating on the System/38 source. For more details on this subject, see "Example" on page 1-14 and Chapter 5, "Coexistence with an AS/400 System."

Object Attributes and Source Types

All programs and files on the AS/400 system have an object attribute. Objects created from source have different attributes, depending on which create command was used. If created by a System/38 environment command, the objects end with a 38, as follows:

Description	AS/400 System	System/38 Environment
CL Program	CLP	CLP38
Logical file	LF	LF38
RPG	RPG	RPG38

For the complete list, see "Object Attributes and Source Types" on page 2-23.

When restoring an object to the AS/400 system that was saved from System/38, the object attribute for files (created from source) and programs is changed to reflect System/38. When you create an object on the AS/400 system, you designate by the command specified whether you are creating an OS/400 program or a System/38 program.

Note: Neither a System/38 nor an OS/400 object can be saved on the AS/400 system and restored on System/38. Only data interchange is supported from the AS/400 system to the System/38.

The attribute of the object you create is dependent on the create command used and not the environment where the create command was run. The following shows two OS/400 programs being created using both the OS/400 syntax and the System/38 syntax.

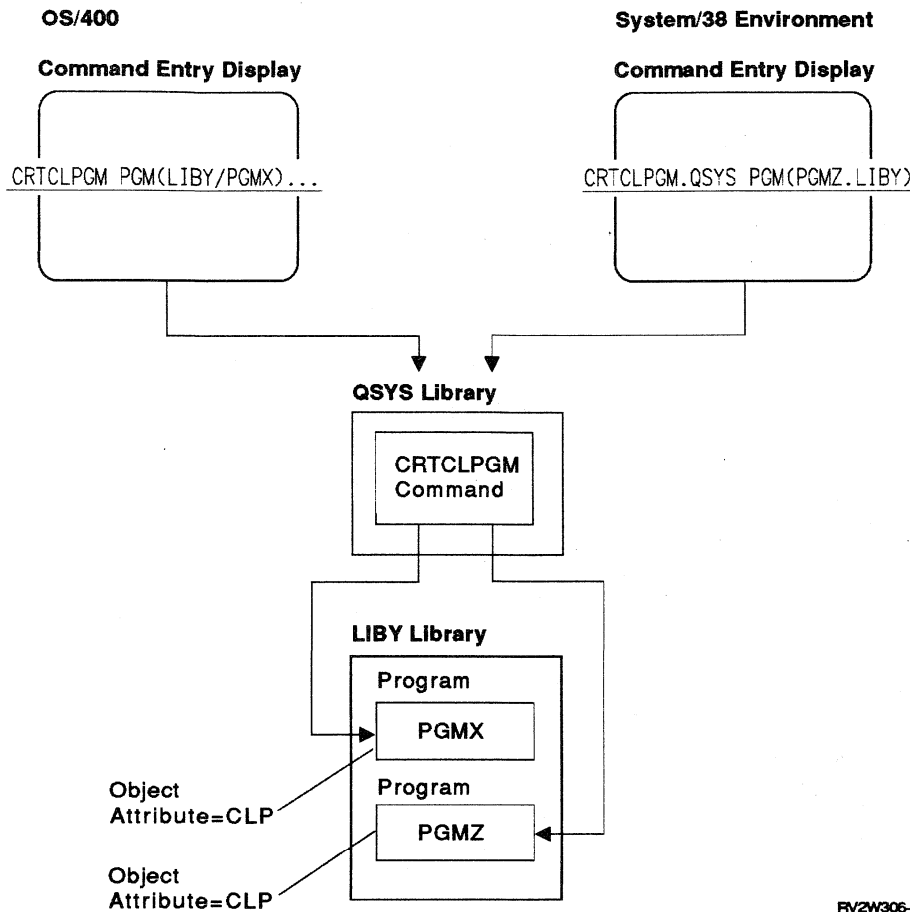

RV2W306-0

Because the System/38 environment command is qualified to library QSYS, an OS/400 object attribute is assigned.

The DSPOBJD and DSPLIB commands show the object attribute so that you can easily determine the command used to create the object. In most cases the object attribute reflects the source type used. The exceptions are:

- It is possible to create an OS/400 object attribute even though the source is System/38 using the create command in QSYS (as shown in the previous illustration). If no errors occur, an OS/400 object can be

created. The inverse is also true, in that a System/38 object attribute can be created using OS/400 source.

- If no source is used, the resulting object always appears with an OS/400 object attribute, regardless of which command was used for the create.

The source file member also contains an indication of the source type. The source types are converted when restored from System/38. DSPFD TYPE(*MBRLIST) shows you the source member type.

The following shows how objects and source are saved from System/38 and restored on the AS/400 system:

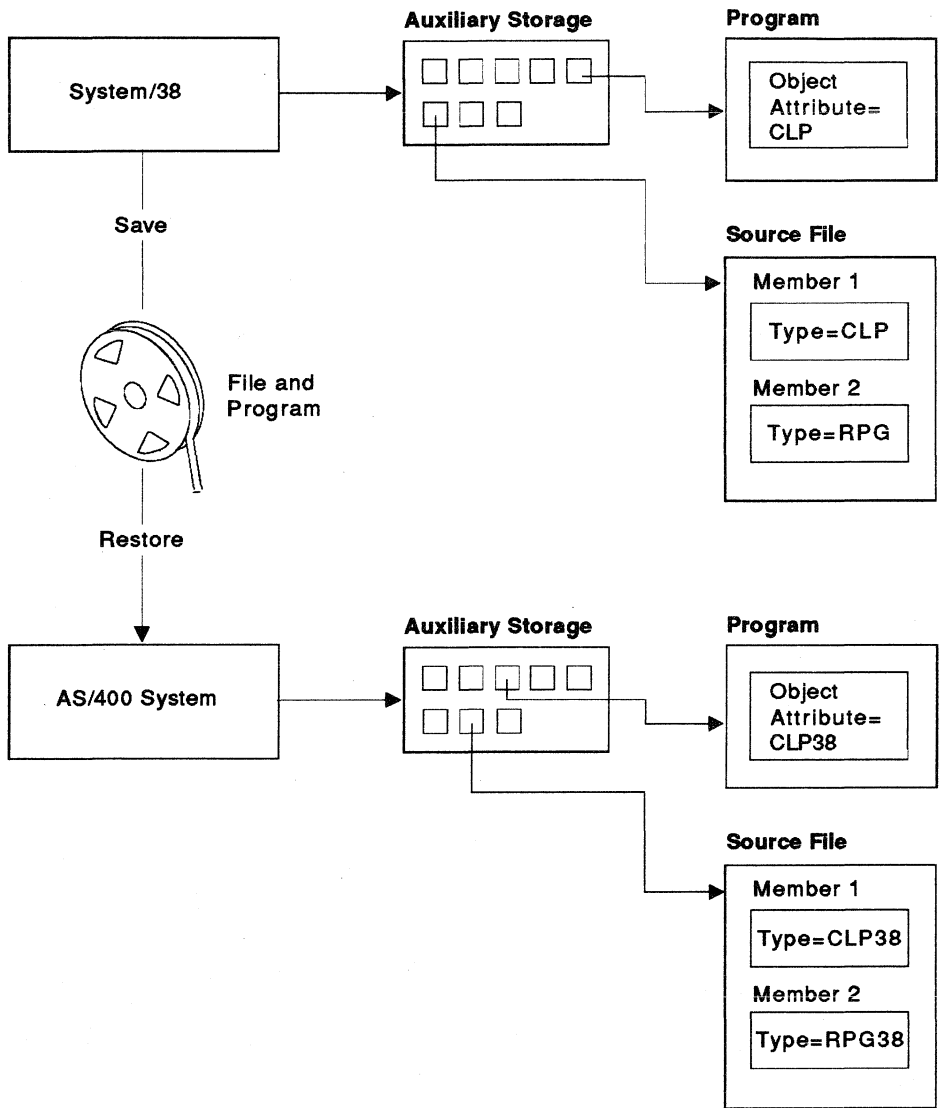

RV2W307-0

Note: Both the object attribute and the source type are changed by the restore function.

The Programmer Menu allows you to designate the source type. You can enter either the OS/400 or System/38 environment source type for the *Type* prompt. The Programmer Menu has been changed somewhat from System/38 and is shown as:

```

      Programmer Menu
      System: xxxxxxxx

Select one of the following:
  1. Start AS/400 Application Development Tools DFU
  2. Work with AS/400 query
  3. Create an object from a source file  object name, type, pgm for CMD
  4. Call a program                      program name
  5. Run a command                      command
  6. Submit a job                       (job name), ,(command)
  7. Go to a menu                       menu name
  8. Edit a source file member          (srcmbr), (type)
  9. Design display format using SDA    (srcmbr), (mode)
  90. Sign off                         (*nolist *list)

Selection ..... _      Parm .....
Type .....            Parm2 ...
Command .....

Source file .....      Source library ..... *LIBL
Object library .. *CURLIB Job description ..... *USRPRF

F3=Exit   F4=Prompt   F6=Display messages  F10=Command entry
F12=Cancel F14=Work with submitted jobs  F18=Work with output
  
```

Note: The Programmer Menu is described in this manual as it should be familiar to most of the System/38 users. However, you should also consider the new programming development manager (PDM), which is part of the AS/400 Application Development Tools.

The *Type* prompt is used for two purposes:

- If you specify the SEU function selection 8 with the determines the syntax checker that value of *Type*, the field is used. Thus, you can enter the System/38 CL source even while operating in the OS/400 program.

The SEU functions for adding, deleting, or updating a statement are identical, regardless of the type of source to be entered. SEU has essentially the same support as that which existed on System/38. The type of source you request controls which syntax checker is used to validate your statements.

In either case, if you are entering CL commands and request the command prompter, you see the OS/400 prompter format, regardless of whether you are entering an OS/400 or System/38 environment command. Only one prompter exists on the system. The OS/400 prompter support differs from System/38 and provides additional benefits over the System/38 support. In addition, online help information to explain the command and the parameters is available

when using the prompter for an OS/400 command.

If you use the prompter while using SEU, the type of source determines the syntax used for the command string to be stored in the source.

The following figure shows what occurs when you use the System/38 source while operating in the OS/400 program.

AS/400 System

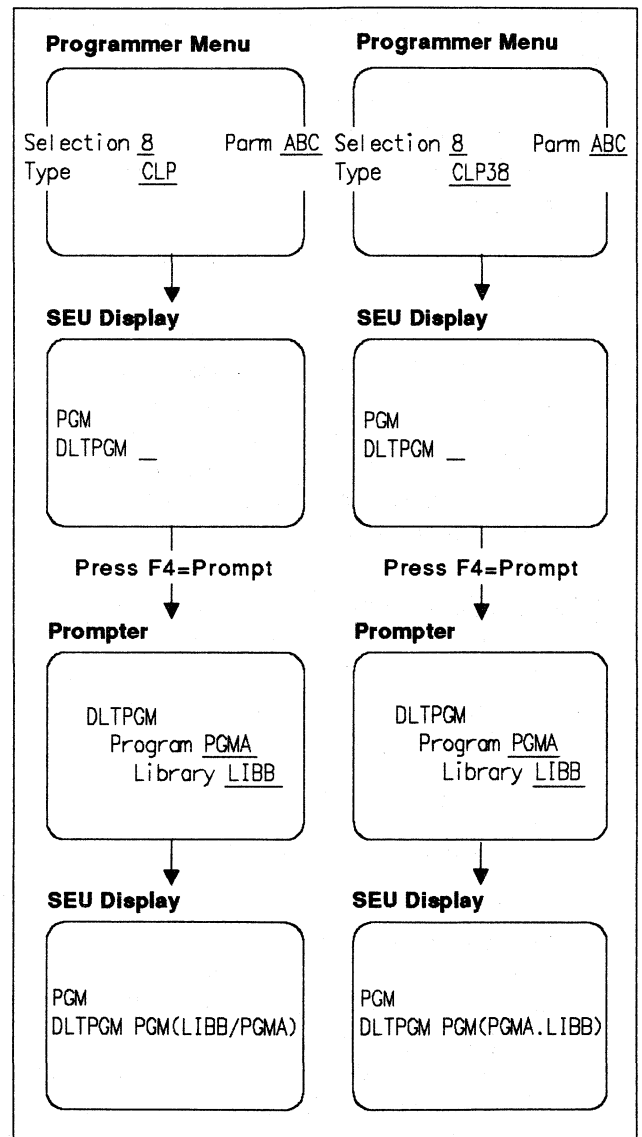

RV2W308-0

- If you specify selection 3 (Create an object from a source file), the correct create command is submitted so that the corresponding attribute (for example, CLP or CLP38) is assigned to the program.

If you do not use the Programmer Menu (or the new Application Development Tools), you must specify the proper create command. For example, if you are on the OS/400 Command Entry display, you must specify QSYS38/CRTCLPGM to create a System/38 environment CL program.

Example

The following is a series of typical tasks that a programmer might perform. The same task is shown for:

- System/38 approach
- AS/400 approach
- AS/400 approach for entering a System/38 program

Assume that you want to perform the following steps:

1. Create a library
2. Place the library on your library list
3. Create a source file in the new library
4. Enter the source for a CL program using SEU
5. Create the program in the new library
6. Submit a CPYF command to batch from the Command Entry display

System/38 Approach: If you are on System/38 (not on the AS/400 system) and are operating on the Programmer Menu, you would issue the following commands:

1. CRTLIB LIB(ABC)
2. ADDLIB LIB(ABC)
3. CRTSRCPF FILE(QCLSRC.ABC)
4. Enter SEU

You would specify Selection = 8, Parm = PGMA, Type = CLP, Source library = ABC, and Object library = ABC (normally you would change the library list of the job description used to include library ABC, but it is not needed in this example). Assume the commands entered into the source member are:

```
PGM      PARM(&FILE &LIB)
DCL      &FILE *CHAR LEN(10)
DCL      &LIB *CHAR LEN(10)
OVRDBF   FILE(INPUT) TOFILE(&FILE.&LIB)
OVRDBF   FILE(OUTPUT) TOFILE(OUTPUT.QTEMP)
CALL     PGMB /* Reads INPUT and writes
          OUTPUT */
CPYF     FROMFILE(OUTPUT.QTEMP)
          TOFILE(MASTER.&LIB)
          MBROPT(*ADD)

ENDPGM
```

5. Specify selection (Create an object from a source file) on the Programmer Menu. A batch job is submitted to create the program.
6. Press F3 to go to command entry.

Enter SBMJOB and request the prompter (for the purpose of this example, assume use of command entry and not selection 6 (Submit a job) from the Programmer Menu).

The prompt is shown for the SBMJOB command. The RQSDTA parameter must contain the CPYF command surrounded with apostrophes. For example, it might be shown as:

```
RQSDTA('CPYF FROMFILE(AAA) TOFILE(BBB)
        MBROPT(*ADD)')
```

Normally, you need to enter a JOBD value for the SBMJOB command.

AS/400 Approach: Assume you want to perform the commands using the OS/400 program. You could operate from command entry, the Programmer Menu, or the programming development manager. Assume you are operating from the Programmer Menu. You would issue the following commands:

1. CRTLIB LIB(ABC)
2. CHGCURLIB CURLIB(ABC)

Normally, you would want the library you are working with to be your current library (this is new support on the AS/400 system, which provides a default for create commands and also places the library on your library list). See "Library" on page 2-16 for more information on the current library.

3. CRTSRCPF FILE(QCLSRC)

The CRTSRCPF command places the file in library ABC. Create commands have been changed for the OS/400 program; the default places the object in the current library.

4. Enter SEU.

Specify Selection = 8 (Edit a source file member), Parm = PGMA and Type = CLP. Take the defaults for Source Library and Object Library because of the use of the CURLIB parameter in step 2. The following would be entered into the source member.

```
PGM      PARM(&FILE &LIB)
DCL      &FILE *CHAR LEN(10)
DCL      &LIB *CHAR LEN(10)
OVRDBF   FILE(INPUT) TOFILE(&LIB/&FILE)
OVRDBF   FILE(OUTPUT) TOFILE(QTEMP/OUTPUT)
CALL     PGMB /* Reads INPUT and writes
          OUTPUT */
CPYF     FROMFILE(QTEMP/OUTPUT)
          TOFILE(&LIB/MASTER)
          MBROPT(*ADD)

ENDPGM
```

Note the use of the AS/400 syntax for qualified names.

5. Use selection 3 (Create an object from a source file) on the Programmer Menu. A batch job is submitted to create the program. The default is to use the library list of the current job. Consequently, the ABC library is on the library list for the batch create step. This is not needed in this example, but normally would be if the program referred to an externally described file in library ABC.
6. Press F10 to go to command entry.

Enter SBMJOB and request the command prompt function (assume the use of command entry).

The command prompt is shown for the SBMJOB command. A new parameter named CMD assumes that you want to submit a command. It is shown on the first display. Enter CPYF and request the command prompt function for the CPYF command by pressing a function key. The CPYF prompts are shown and you enter information as required. You normally do not need to specify a job description for the SBMJOB command because of the default changes on the SBMJOB command. For

example, the library list of your current job is the default for the batch job. The JOBID default has changed to refer to the JOBID specified in the user profile.

AS/400 Approach with Entry of System/38 Environment Program:

The user is operating using the OS/400 program, but wants to create a System/38 environment program. For example, you may continue to maintain System/38 programs until you are ready to convert.

This example would be a combination of the previous ones.

Steps 1, 2, and 3 would be the same as in the AS/400 example.

Step 4 would be the same except that the source type would be CLP38. The source to be entered would be the System/38 syntax from the System/38 example.

Step 5 would duplicate the AS/400 example. Because the source type was previously set to CLP38, the correct create command would be submitted to batch.

Step 6 would be the same as in the AS/400 example.

Migrating Multiple System/38s to a Single AS/400 System

If you are going to migrate multiple System/38s to a single AS/400 system you need to consider such things as:

- Duplicate user profile names
- Duplicate library names (for example, QGPL)
- Duplicate object names
- Duplicate user IDs and office names

The Migration Aid provides some information, but you must be careful of duplicate names.

Chapter 2. Changes Needed after Migration

This chapter describes the changes necessary for a migration from System/38 to the System/38 environment on the AS/400 system. The programming and operational differences are identified in detail. Chapter 1 provided an overview and identified the hardware differences.

The chapter is divided into the following sections:

- Operating System/400* program
- Utilities and other licensed programs
- Languages

Within each section the subtopics are listed in alphabetical order.

Two additional considerations that do not fall into these general sections are:

- IBM display and printed formats have changed. The System/38 programs that process a spooled version (for example, CPYSPLF) may need to be changed.
- The multilingual support that allows different languages to be used for command prompts is not supported in the System/38 environment. Multilingual support exists only on the OS/400 program.

Operating System/400 Program

This section identifies the programming and operational differences in the Operating System/400 program.

Access Paths: The following access paths are not loaded and are rebuilt by the system as part of the restore:

- Access paths of logical files with DBCS keys that have attributes that differ from the attributes of the physical files over which they were created
- Access paths with SELECT/OMIT that reference DBCS fields

Other access paths are restored. They are not rebuilt assuming the access path was saved from System/38. Also see the discussion on

keywords in "Database" on page 2-5 for the changes to the ACCPTH keyword.

Address Regeneration: On System/38, the system assigns internal addresses and has a fixed limit to the number that can be assigned. Two address types, *Permanent* and *Temporary*, are used and both percentages of the addresses used are shown using DSPSYSSTS. On System/38, the temporary addresses are generated again at each initial program load (IPL), and you must periodically generate the permanent addresses again.

On the AS/400 system, both permanent and temporary addresses are generated at each IPL. Thus, you do not have to schedule dedicated system time to perform address generation, but you do have to do an IPL frequently enough so that the addresses are not used up. Minimal additional overhead is caused by generating these addresses at IPL.

Alerts

Format: The format of the alerts has been changed to agree with the SNA Management Services Generic Alerts. System/38 required stored screens on the System/370 (for example, NetView* Distribution Manager). For the OS/400 program, the information is sent in the alert and the screen is dynamically formatted.

Network attributes: The Alert Network attributes must be described on the AS/400 system. They are not migrated by the Migration Aid. For more details, see "Network Attributes" on page 2-22.

NetView Distribution Manager: The host system must have at least Release 2, Modification Level 0, of NetView installed.

Logging: On System/38, alerts were logged to the journal QALERT. This has been changed to a database file (QALERT in QSYS) on the OS/400 program. The QALERT journal is not migrated by the Migration Aid.

For more information about messages in general, see "Message Handling" on page 2-19.

APPC: To operate in the System/38 environment, the device configuration objects must specify APPN(*NO). For more information on operating in the System/38 environment, see also "Data Description Specifications (DDS)" on page 2-6.

Auxiliary Storage Pools (ASP): User auxiliary storage pools are not migrated. You must define them on the AS/400 system using the new dedicated service tools (DST) function. DST is also used to set each ASP threshold including the system ASP threshold that was specified on System/38 using the QAUXSTGTH system value. See "Service" on page 2-44 and the *Backup and Recovery Guide*.

BSC: See "Data Description Specifications (DDS)" on page 2-6.

Card: Card devices and card files are not supported on the AS/400 system.

Chart Format: Chart formats created by AS/400 Business Graphics Utility (BGU) contain the chart heading that is part of the chart data in System/38 BGU. AS/400 BGU chart formats contain some chart characteristics that are new on AS/400 BGU such as offset pie chart and overlapped bars.

Checksums

Definition: Checksums are not migrated. You must define them on the OS/400 program using the new DST function (see "Service" on page 2-44). The *Backup and Recovery Guide* contains more information.

Load/Source device: The Load/Source device (the device that contains the licensed internal code) cannot be in a checksum set. The Load/Source device is designated prior to restoring the system. The Load/Source device is used for unprotected storage in the same manner as the first 62PC on System/38. Either a 9332 or 9335 Disk Unit can be the Load/Source device.

A Load/Source device is defined to be an actuator or unit. Thus half of a 9335 or half of a 9332 (Model 400) can be designated as the Load/Source device.

Like devices: A new function allows a minimum of two like disk device units to make up a checksum set instead of three. If you have two disk device units in a checksum set, you are devoting approximately 50% of the space to checksum data.

Class Object: No changes.

Command Definition: No special System/38 environment support exists for command definition. You can write command definitions so the commands can be used in either the System/38 environment or the OS/400 program. Additional functions for command definition allow, for example, the prompter to respond with layered prompts based on user input (see "Prompter" on page 2-28). Other command considerations include:

Parameters: On System/38, the definition for a parameter that includes a typical qualified name (OBJ.LIB) is:

```
PARM KWD(PGM) TYPE(QUAL1) ....
QUAL1: QUAL TYPE(*NAME) /* Program */ .....
        QUAL TYPE(*NAME) /* Library */ .....
```

This allows the parameter to be entered as either:

```
System/38          PGM(PGMX)
                   PGM(PGMX.LIBY)
```

Using the command prompter, the parameter would be shown as follows:

```
Program name ..... _____
Library name ..... *LIBL _____
```

If you use the prompter for this parameter in the System/38 environment, it appears the same as on System/38.

On the OS/400 program, you would code the command definition statements in exactly the same order and the command prompt would appear the same. However, when the parameter is entered in string form, it must be coded as either:

```
OS/400      or      PGM(PGMX)
                   PGM(LIBY/PGMX)
```

Assume you are using SEU and have specified source type CLP. When you use the prompter with a specific command name, a qualified name appears as shown previously. When the

command is returned as a source statement, it is shown in OS/400 syntax form (LIB/OBJ) because the type CLP requests OS/400 syntax. If you had entered SEU specifying source type CLP38, the command would have been returned in System/38 syntax (OBJ.LIB).

For qualified names, no difference exists between System/38 and the OS/400 program for how command definition is coded. The major difference occurs in how a qualified name is keyed in string form or appears after using the prompter (using either SEU or command entry).

The command processing program should be coded to extract the qualified names using the SUBSTRING function in the same order in which the command definition is coded. This is the same as it was on System/38. In the previous example, the qualified name would be passed to the command processing program as:

```
'PGMX      LIBY      '
```

There is new support on the AS/400 system for a product library associated with the command. This allows the command user to have only the library containing the command on his library list (the library containing the command processing program is not needed). See the product library discussion in "Library" on page 2-16.

It is possible to take advantage of the product library (PRDLIB) support in command definition and have it used in the System/38 environment. For example, the System/38 environment commands for languages and utilities support this so that the individual product libraries do not have to be on the library list.

It is also possible to take advantage of the layered prompt support and use it in the System/38 environment.

Number of parameters: Some IBM command-processing programs have changed in the number of parameters they receive. If you use your own version of an IBM command-processing program, you need to reevaluate the parameter list passed from the command.

Validity checking: A validity checking program can also be specified for an IBM command. If you have specified a validity-checking program for an IBM-supplied command, you need to re-

evaluate the parameter list passed from the command.

Printed output: The name of the printed output produced by the CRTCMD command has changed from QSYSPRT to the name of the source member being created. The format of the printed output has minor changes.

Command Language: Many changes have been made to commands. (See Appendix A for a summary by command.) In some cases, the System/38 environment allows a command to exist so that it may be used for coexistence purposes (for example, maintaining source that will be used on System/38), but will not run on the AS/400 system. If you attempt to use such a command on the OS/400 program, an escape message is sent. All commands are shipped with the system. However, if the program supporting that command does not exist, an error message is displayed. Additional changes are as follows:

Syntax: No syntax differences exist between System/38 CL and the System/38 environment (a valid comment on System/38 and the specification of a qualified name are the same on System/38 as they are in the System/38 environment). However, syntax differences exist between how commands and comments are written in the System/38 environment versus on the OS/400 program. The command changes were highlighted in Chapter 1 and the details of both changes are discussed in Chapter 4.

RTVCLSRC: The RTVCLSRC command retrieves the source in the syntax that was used to create the program. For example, if the program is a CLP38 program, you receive the System/38 syntax regardless of which environment is used to run the RTVCLSRC command.

Naming: See "Naming" on page 2-22 to understand changes in how a name must be specified.

ALWRTVSRC parameter: CL programs can be successfully migrated even if ALWRTVSRC(*NO) was specified on the CRTCLPGM command.

Printed output: The name of the printed output produced by the CRTCLPGM command has changed from QSYSPRT to the name of the source member used to create the command.

Commitment Control: No coding changes. However, the number of record locks supported in a routing step has increased from 1024 to 4096.

Communications: Changes in the communications operations must be considered when operating on the AS/400 system.

Configuration: Many communications functions are specified through device configuration commands. The device configuration specifications have changed (see "Device Configuration" on page 2-7).

Errors: The error messages and device error codes that relate to hardware errors, and are predominantly sent to QSYSOPR, have changed. Some message IDs have changed.

CSNAP: No CSNAP commands exist. Some of the same function can be achieved using the device configuration THRESHOLD parameter.

References: See also the sections on:

- "Alerts" on page 5-5
- "APPC" on page 2-2
- "Data Description Specifications (DDS)" on page 2-6
- "Emulation (3270)" on page 2-11
- "Exchange ID" on page 2-12
- "LU-1" on page 2-18 LU-1
- "Object Distribution" on page 2-25
- "Pass-Through" on page 2-25
- "RA/DHCF" on page 2-28
- "Remote Location Name (RMTLOCNAME)" on page 2-28
- "Return Codes" on page 2-35
- "SNADS" on page 2-47
- "X.25" on page 2-61

Communications File: See "Data Description Specifications (DDS)" on page 2-6.

Copy File (CPYF)

Data interchange: When copying for data interchange, you must be aware of the diskette and tape differences. See "Diskette" on page 2-10 and "Tape" on page 2-58.

Large files: Better spreading of large files occurs automatically as with the restore function. This is discussed in "Save and Restore" on page 2-35.

DBCS: Copy file requires specifying FMTOPT(*MAP) or FMTOPT(*NOCHK) when copying results in DBCS mapping errors. Truncation and padding of DBCS fields maintains shift-in/shift-out pairs. Database conversion errors may occur when the data does not conform to the to-file DBCS field.

Position Errors: When copying multiple member files, processing will continue to the next member if a from-file member fails to open due to a position open error.

Distributed Data Management (DDM): DDM files can be specified as both a FROMFILE and a TOFILE. Copy file allows a remote file to be created with DDM. The *Data Management Guide* contains more information.

Console: The AS/400 system does not have a unique device for a console. The first device assigned (Bus 0, first work station controller, Port 0, and Address 0) is considered the console device. During IPL, the device description QCONSOLE that is attached to controller description QCTL is used for the console. After IPL, the name of the console device description can be determined from a system value (QCONSOLE). QCONSOLE will reflect the name of the console device currently varied on. This system value cannot be changed.

The console device must be:

- A 5250 device (for example, 5251 or 3180)
- A personal computer that uses an emulation adapter
- An ASCII 315x/316x

Note: After IPL, the system-created QCONSOLE device description and its related work station message queue still exist. If you have application programs that send messages to the QCONSOLE device, they should be changed. If no change is made, the message will be sent to the system-created work station message queue named QCONSOLE.

Cross-Reference

Object attribute and source type changes:

Several changes on the DSPFD function are associated with the object attribute changes. See "Object Attributes and Source Types" on page 2-23 for details on the attributes.

- DSPFD TYPE(*MBRLIST) display. The new source types are displayed.
- DSPFD TYPE(*MBRLIST) OUTFILE support (QAFDMBRL file). The MLSEU field contains the object attribute. Because this field is only 4 characters long, it contains entries like PF and DSPF regardless of type (for example, PF or PF38). A new field MLSEU2 is added that is 10 characters long and it contains the full attribute. The MLFILA field remains the same.
- DSPFD TYPE(*MBR) OUTFILE support (QAFDMBR file). The MBSEU field contains the new object attribute. Because this field is only 4 characters long, it contains entries like PF and DSPF regardless of type (for example, PF or PF38). A new field MBSEU2 is added that is 10 characters long and it contains the full attribute. The MBFILA field remains the same.

Any new fields are added at the end of the format to allow existing programs to operate the same way.

DSPOBJD outfile changes exist for the values in the ODOBAT field (for example, CLP38 and CLP). The ODOBTP field may contain the new value *CTLD (the System/38 value was *CUD).

DSPPGMADP outfile changes for the values in the PAATTR field (for example, CLP38 and CLP).

Other DSPFD changes: Other changes associated with the DSPFD function include:

- The QAFDCRD file for card files is not supported.
- The QAFDACCP file no longer reflects an S-type entry in the APACCP field. This is also true of the QAFDMBR file for the MBACCP field. See "Database" for more information on these fields.
- The QAFDDKT fields for DKLOC, DKSLOC, and DKELOC have been changed to the single reserved field DKLOC.

- The QAFDPRT fields PRPRTI, PRPTIL, PRTRNT, and PRTRTL have been replaced by the single field PRPRTI. The field PRLPI may contain new values.
- The value in the following DSPFD outfile fields is changed from an 'N' to a 'Y' when the database file is on an AS/400 system or on a remote System/38.

Field	Outfile	Associated Command
ATFLS	QAFDBASI	DSPFD TYPE(*BASATR)
MBFLS	QAFDMBR	DSPFD TYPE(*MBR)
PHFLS	QAFDPHY	DSPFD FILEATR(*PF)
LGFLS	QAFDLGL	DSPFD FILEATR(*LF)

Data Area: No changes.

Database

Keywords: The DDS ACCPTH keyword has a different meaning. This keyword described explicit access path sharing on System/38. On the AS/400 system, this is only used to copy the key and select and omit specification and the values for DYNSTL, FIFO, LIFO, UNIQUE and ALTSEQ to the logical file being created. (Specifying ACCPTH avoids having to key in the specifications again, but does not guarantee sharing with the file.) Implicit access-path sharing occurs by default. (After migration, you could see a file begin sharing an access path or sharing a different access path.)

Because of this change, the ACCPTHMBR keyword is ignored for the CRTLF and ADDLFM commands. The DTAMBR(*ALL) function may need to name specific members because it cannot use the ACCPTHMBR parameter value.

The DSPFD output file QAFDACCP no longer reflects an S type in the APACCP field.

FIFO sequence: A change relative to the use of first in and first out (FIFO) sequence occurs if the file is re-created as an OS/400 file. This should not affect your operations if you continue to use the System/38 file.

To assist you in changing your current DDS source, the FIFO keyword is allowed for PF38 or LF38 type files. A low-level warning is produced if FIFO is used to create a System/38 file. The intent of this is to allow you to change your source even while operating in the System/38

environment in anticipation of the conversion to OS/400 files.

For a full discussion of this change, see Chapter 4.

SQL: To conform with the IBM Structured Query Language/400 (SQL/400*) standard, the authority required to create an arrival-sequence logical file over a physical file is not the object management authority. Object management authority is still required to create a keyed logical file.

Field mapping: If a field mapping function is used (for example, converting of a field containing different decimal positions between a physical and logical file) and mapping errors are encountered, some different processing results occur. See the explanation of field mapping errors in the "Database" section of the *Database Guide*.

DBCS: Default values of DBCS-only fields (in physical files) is enclosed in shift-out and shift-in characters. They were previously all blanks.

All DBCS data inserted or updated must be valid for the given DBCS subtype or mapping errors occur.

Allowed mapping of DBCS data between physical and logical files has changed (the *Database Guide* contains more information). When files created on a System/38 and restored on an AS/400 system show disallowed mapping, the logical file's invalid data type is changed to DBCS open. The file is restorable.

OPNQRYF: See "Overrides" on page 2-25 for a change with OPNQRYF processing and the restriction with OPNQRYF using Distributed Data Management (DDM) in "Utilities and Other Licensed Programs" on page 2-61.

See also "Data Description Specifications (DDS)."

DBCS fields: The OS/400 database support has been enhanced to allow two additional data types for DBCS fields. They are J for DBCS—only and E for DBCS—either. These are in addition to the data type of O for DBCS—open that is supported on the System/38. Files migrated from System/38 or created in the System/38 environment do not need to make any changes. The database support determines the

data type based on the values specified in the REFSHIFT DDS keyword. Both the DDS expanded source listing and the output from the DSPFFD command show the assumed data type instead of the REFSHIFT keyword.

Data Description Specifications (DDS):

Changes in DDS must be considered when operating in the AS/400 system.

Source types: BSCF38, CMNF38, and MXDF38 source types are available only in the System/38 environment. In the OS/400 program, the inter-system communications function (ICF) file has replaced the BSC, CMN, and MXD files. The ICF source type is ICFF. Many communications functions are specified through device configuration commands. These have changed (see "Device Configuration" on page 2-7). Many of the error messages that relate to hardware errors have changed. The message IDs remain the same, but the device error codes have changed.

Security keyword: CMNF38 and MXDF38 source using the SECURITY(02 *PASSWORD) keyword is not supported. A file containing this value is not restored on the AS/400 system.

CMNF38 and MXDF38 use of the SECURITY keyword supports a maximum length of 10 characters. An 11-byte field or literal produces a diagnostic message (severity 20) during file creation.

FIFO keyword: The FIFO keyword may be used for database files. This produces a warning message (see "Database" on page 2-5).

Access path keyword: The ACCPTH keyword for logical files has changed. See "Database" on page 2-5.

FORMAT keyword: It is no longer valid to specify a logical file on the FORMAT keyword in the DDS for a physical file. Only a format from another physical file can be shared. When migration occurs, any sharing is implicitly handled so no change is required. However, if the same DDS that existed on System/38 is used to re-create the file, an error occurs.

Display files: Display files using only the DSPSIZ keyword value of *DS1 (16-by-64 console) or *DS2 (12-by-80 5250 Model 1) cannot be restored or created on the AS/400 system

(the 16-by-24 and 12-by-80 display sizes are not supported).

If the file uses a *DS1 and/or *DS2 type and also a valid display size (for example, *DS3), the file is restored. The file can be created using the original source, but a diagnostic message is produced.

For display files, a field can end in the last position of the display (it does not wrap to line 1, position 1).

For display files, a field can be defined to start in line 1, position 1 when SLNO(*VAR) is specified. When a format is written to the display device, an error message is sent if the actual line number is 1.

DBCS: Some changes have been made to the data types for DBCS fields (see "Database" on page 2-5).

Printed output: The name of the printed output used by the DDS create commands is the name of the file being created instead of QPDDSSRC.

The format of the expanded source printed output is shown in OS/400 syntax (LIB/OBJ). The format of the DDS create printout has changed.

The message IDs for many of the messages in the DDS create printed output have changed.

Data Queue: The maximum record length of data queues has changed to 4096. The Migration Aid or save and restore migrates the object description, but not the data queue entries.

Debug

Authority: Debugging a program requires *CHANGE authority to a program rather than *READ authority, as on System/38. The System/38 default for PUBAUT(*NORMAL) is to provide all the data authority. Consequently, it makes no difference if the CRTXXXPGM defaults were taken on System/38 and continue to be taken on the AS/400 system. However, if you have changed the data authorities to prevent users from using debug, you need to make a different change on the AS/400 system.

The purpose of the change is to allow a simple specification (*USE) in the OS/400 program that allows running a program, but prevents debugging.

Command entry: The Command Entry function accessed from the Debug Breakpoint display assumes OS/400 syntax.

See "Problem Determination" on page 2-26.

Dedicated Service Tools (DST): See "Service" on page 2-44.

Device Configuration: Device and communications configuration has been significantly changed from System/38. The System/38 CRT and CHG device configuration commands cannot be run on the AS/400 system. However, they can be used in the System/38 environment SEU.

New commands: New commands are available as well as menu and prompter support (including help information) to do configuration. Instead of a single CRT and CHG command for device descriptions, now different commands are used for the type of device to be created or changed. The same is also true of the controller and line description objects.

The use of multiple commands allows each command to contain parameters that are specifically associated with the type of object. For example, you do not see BSC parameters when creating a local work station device.

The CRTDEVD command has been split into individual commands and each CRT command has a corresponding CHG command. Some of the commands and parameters support functions that are not on System/38. The commands should be read as "Create Device Description xxxx" where xxxx is the type. See the *CL Reference* manual for a complete description of all CL commands. The following is a list of some of the new commands:

Command	Device
CRTDEVAPPC	APPC
CRTDEVASC	Asynchronous
CRTDEVBSC	Bisynchronous
CRTDEVDKT	Diskette
CRTDEVDSP	Display
CRTDEVFNC	Finance
CRTDEVHOST	SNA Host

CRTDEVPRT	Printer
CRTDEVSNUF	SNA Upline Facility
CRTDEVTAP	Tape

The CRTAUD command has been split into individual commands and each CRT command has a corresponding CHG command. Some of the commands and parameters support functions that are not on System/38. The commands should be read as "Create Controller Description xxxx" where xxxx is the type. The following is a list of some of the new commands:

Command	Device
CRTCTLAPPC	APPC
CRTCTLASC	Asynchronous
CRTCTLBSC	Bisynchronous
CRTCTLFNC	Finance
CRTCTLHOST	SNA Host
CRTCTLLWS	Local Work Station
CRTCTLRWS	Remote Work Station
CRTCTLVWS	Virtual Work Station

The CRTLIND command has been split into individual commands and each CRT command has a corresponding CHG command. Some of the commands and parameters support functions that are not on System/38. The commands should be read as "Create Line Description xxxx" where xxxx is the type. The following is a list of some of the new commands.

Command	Device
CRTLINASC	Asynchronous
CRTLINBSC	Bisynchronous
CRTLINS DLC	SDLC
CRTLINTDLC	Twinaxial Data Link Control
CRTLINTRN	IBM Token-Ring Network
CRTLINX25	X.25

The device mode function has changed. Device modes are now specified as a separate new object type and the device description contains an entry that points to the new object. The System/38 commands ADDDEVMODE, CHGDEVMODE, and RMVDEVMODE are no longer supported. See the online help information for the CRTMODD and CHGMODD OS/400 commands.

Migration Aid: The Migration Aid performs an important function relative to device configuration. The configuration is saved from System/38 and the Migration Aid must be used to restore the configuration to the AS/400 system. Unsup-

ported devices (for example, diskette magazine device) are ignored by the migration function.

The Migration Aid is the only way you can automate the migration of your existing device configuration. If you have device configuration commands in CL job streams or CL programs, the data might be of value in determining what to enter, but the commands cannot be used on the OS/400 program. CVTCLSRC does not convert these commands.

Automatic configuration: A new system value (QAUTOCFG) controls the use of automatic configuration for local devices and controllers. The default value is 1, or on, specifying that automatic configuration should be in effect.

If automatic configuration is requested, the system automatically creates a device description for any local device (display station, tape unit, printer, and diskette unit) as soon as the device is turned on. Local controller descriptions are automatically created. A system defined name is associated with each object created. Default attributes are assigned. The attributes that can be changed by the CHG commands can be used to change the attributes regardless of how the object was created (not all create parameters exist on the CHG commands).

Note: You cannot change the name of a device configuration object (to change the name you must delete the object and then re-create it). See the *Device Configuration Guide* for specific information.

If you do not want to automatically configure the local devices and controllers, you must change the QAUTOCFG system value to 0, or off. To create a device or controller you would issue a CRTxxxx command or use an IBM-supplied menu.

Although local devices can be automatically configured, you must manually configure your remote devices, controllers, and lines. Automatic configuration requires that you use the system-supplied naming conventions for your devices.

The naming convention for automatically configured local work stations is dependent on the QDEVNAMING system value. If QDEVNAMING is *NORMAL, then the work stations are named DSPnn, where nn is a consecutive number. If

QDEVNAMING is *DEVADR, then the work stations are named DSPxxyzz, where xx is the number of the local work station controller to which the work station is attached, yy is the port the work station is on, and zz is the work station's switch setting. For example, DSP010203 is for a work station on port 2 with a switch setting of 3 on the first local work station controller.

When a work station is automatically configured, the system attempts to dynamically allocate it to a subsystem. Thus, if you are assigning work stations to subsystems by work station name rather than work station type, you will need to know what name will be generated for a work station before it is automatically configured (so you can set up the subsystem with the correct work station entries). This is generally not practical when QDEVNAMING is *NORMAL, but when QDEVNAMING is *DEVADR, the work station's name can be determined from its address.

Change configuration: The Change Device command has been enhanced so that you can change the address and the keyboard if the device is varied off.

Work station allocation: Regardless of how you perform the device configuration function, the system supports dynamic work station allocation to subsystems. This is a significant enhancement over System/38 in that you can add local work station devices and have the *Sign on* prompt appear without ending the subsystem session and varying off the controller. If you are inserting a work station device in the middle of devices configured with cable-through, the devices on the end of the string must be signed off before the physical connection is interrupted.

The dynamic work station allocation function is dependent on the subsystem description ADDWSE entry. This can be any of the following:

- Any generic device name. For example, if you plan to name all of your devices starting with the letters LOCAL, you can use the ADDWSE command with the WRKSTN parameter to enter an entry LOCAL*. When devices are created starting with the letters LOCAL, the subsystem will allocate these devices dynamically.
- Any valid work station. For example, if the ADDWSE WRKSTNTYPE parameter is set to

*ALL, any valid work station device is dynamically allocated to the subsystem when the device is created.

The default shipped for the IBM subsystems is to have the *ALL ADDWSE command entry. This means that the shipped values use the defaults to allocate the work station device (present the Sign-On display) when a device description is created.

- Any work station type. For example, if the ADDWSE WRKSTNTYPE parameter is used to request any 5250 device, any new 5250 device is dynamically allocated to the subsystem when the device is created.
- A specific device name of an unconfigured device. For example, you could know ahead of time that you are going to assign the name DEV09 to the next work station device. If this device is specified for the ADDWSE WRKSTN parameter, the subsystem acquires the device if the device description is created. You can only use the ADDWSE command when the subsystem is inactive. Consequently, you must plan ahead to use the dynamic work station addition capability if you are specifically assigning work station devices to subsystems.

For example, you could develop several WRKSTN names associated with any subsystem that do not represent actual devices. When the subsystem is started, a message is sent to QSYSOPR stating the device could not be allocated. If you eventually create a device of the same name, the Sign-On display is shown when the device is turned on. Another alternative would be to add some temporary work station entries (for example, TEMP1 and TEMP2) and use these as a temporary name of the device. At a convenient later point, you could configure the device with a name that meets your naming convention and change the subsystem description.

Note: The support for the local work station controller and the 5294/5394 remote controller differ. On the local work station controller, you can plug in the new device without varying off the controller.

The 5294/5394 remote controller has its own setup requirements. You must vary off the controller before a new device can be physically added. (It is still required that all devices

attached to the 5294/5394 be signed off and varied off before you can add a device.)

Printer file names: The printer file names used by the display commands have changed as follows:

Command	System/38	AS/400 Names
DSPCTLD	QPDCCTLU	QPDCCTL
DSPDEVD	QPDCDEVD	QPDCDEV

Note: The DSPCTLD command on System/38 was DSPCUD.

Vary commands: The System/38 VRYxxx commands are in the System/38 environment. The AS/400 approach is to use a single command named VRYCFG. This new command has the optional capability of providing a **cascading vary** function. A cascading vary means that when you vary on the controller the attached devices are also varied on (System/38 supported this from the DSPLINSTS and DSPCTLSTS menus, but not from the VRY commands).

The VRY commands operate differently on the AS/400 system. They send a request to a standard internal routine to perform the vary. Because the system does not wait for low-level machine processing, you see a faster return response from an individual command. However, actual completion can no longer be assumed on receipt of the completion message. The same escape messages exist.

Display configuration: The DSPDEVCFG command is not supported. This displayed or printed some, but not all, of the device configuration attributes. You can achieve similar results from the WRK commands and request a display of each description. You can also program for the same function using the DSPOBJD outfile support and the DSPxxxD commands. See the sample program in Appendix D or the PRTDEVCFG tool in the QUSRTOOL library.

***PU2 controller:** For the *PU2 controller type on System/38, the CTLADR parameter must begin with a 00 address. On the OS/400 program, the parameter is now named STNADR and the value must be 01 through FF. The Migration Aid implicitly changes the value to 01.

Other commands: The other device configuration commands (for example, DLTxxx) remain essentially the same for both System/38 and in the System/38 environment as in the System/38, but some of the names have changed (see Appendix A).

Device Files: See the sections on the different devices (for example, diskette and printer) and "Data Description Specifications (DDS)" on page 2-6.

Diskette

Diskette device: No diskette magazine device exists. A single-slot diskette device is optional and is supported for data interchange and save and restore. If you have programs that use diskettes and your configuration does not include a diskette unit on the OS/400 program, you need to convert the programs.

The diskette LOC parameter is replaced as the default in the System/38 environment to the single-slot diskette. For many applications, this causes no change. However, differences may occur. For example, if you have a program that deals with the magazine and keeps clearing and saving to successive diskettes, the net result is that only the last save would appear on the single diskette. You need to rework this application. Another example is where you have a program that initializes diskettes in a magazine.

Default device name: The default diskette-device name created by the system is DKT01. If you use the diskette with the System/38 environment commands, they assume the name QDKT. You need to do one of the following:

- Operate only with OS/400 commands.
- Create a diskette device description name QDKT and delete the system-created DKT01 object.

Repair utility: The Diskette Repair Utility is not supported.

Display Commands: Some display commands (DSPxxx) have changed to prevent user changes. This also affects the System Request menu. From the System Request menu on System/38, the user could delete objects in libraries, change job attributes, and delete spool files using the DSPJOB function. Now DSPJOB

and all DSPxxx commands contain only options that do not result in a change. For example, when DSPLIB is used, option 9 (Delete) is no longer supported to allow a delete of an object. This is an integrity feature to allow you to specify read-only functions that can be accessed from user-written menus.

New OS/400 commands (for example, EDTxxx and WRKxxx) allow changes. In the OS/400 program, DSPxxx commands are consistently read-only functions. In the System/38 environment, most DSPxxx commands allow changes.

Display Files: See “Data Description Specifications (DDS)” on page 2-6.

Display Formatting

Display output: Display formatting for many commands has changed significantly. Those displays allowing a parameter to be entered (for example, DSPOUTQ) require that the parameter be entered in AS/400 format. For example, to move a spooled file to a different queue using a qualified name, the parameter would be specified as:

```
OUTQ(LIBX/OUTQA)
```

The unqualified form looks the same as it did on System/38:

```
OUTQ(OUTQA)
```

The Help key is supported for many IBM displays; online help information is shown to assist in understanding the functions provided.

For color displays, changes in the use of color for required fields, optional fields, and error messages have been made.

Function keys: Function keys have changed for IBM displays. These are the major changes:

System/38	Description	AS/400 System	Description
F1	Exit the function	F3	Exit the function
F2	Previous	F12	Cancel

The displays provide for help information to explain how the function keys are used. In most cases, a delete request will cause a confirmation display to allow verification of the deletion.

Display options: When a display allowing options (for example, DSPOUTQ) is used, the option numbers have changed. These are the major changes:

System/38	AS/400 System	Description
1	5	Display
9	4	Delete

The displays provide for help information to explain the option choices.

Distributed Data Management (DDM):

See “Utilities and Other Licensed Programs” on page 2-61 and “Interchanging Using DDM” on page 5-2.

Edit Descriptions:

No functional changes. The edit descriptions are not migrated by the Migration Aid. A sample program is included in the *System/38 to AS/400 Migration Aid User's Guide and Reference* to illustrate how this could be addressed.

Emulation (3270)

Attention key: The Attention key is used instead of the Help key to interrupt the 3270 Application display. New functions exist on the Interrupt display. New support allows the Attention key to be pressed from the Interrupt display if the SETATNPGM command had been issued previously. Thus the group job function can be used with a 3270 emulation job and a new group job can be accessed by pressing the Attention key twice.

BSC: The supported binary synchronous communication (BSC) emulation character sets have been upgraded to emulate a 3274 Control Unit.

Keyboard support: The EML3270 command does not support the keyboard types for certain non-English languages. These are the KBDTYP entries of FSB, FSI, BRB, and BRI.

Error Handling: Many of the messages sent to QSYSOPR for error conditions have changed. For communications messages, the 2-byte error code has been expanded to 4 bytes and the codes have changed.

I/O feedback areas presented to the System/38

programs and escape messages remain essentially the same. They are compatible from the System/38 to the System/38 environment. No changes are required.

Message text has been changed in some cases to reflect new function or terminology.

See also "Return Codes" on page 2-35.

Exchange ID: System/38 uses an exchange ID prefix of 022. The OS/400 program is a different system and the prefix has changed to 056. Systems communicating to System/38 that are replaced by an AS/400 system and use the exchange ID must make a change to the ID prefix. See "Exchange ID" on page 5-1.

Files: See "Database" on page 2-5 and "Data Description Specifications (DDS)" on page 2-6.

Finance: The DSPFNCHLP command is not supported in either the System/38 environment or the OS/400 program. New help support using the Help key on displays is provided in place of the System/38 support.

Graphical Data Display Manager

(GDDM): No changes. Additional functions are available along with new program calls.

Graphics Symbol Set: No changes.

Group Jobs: A new user profile parameter exists to allow you to set the Attention key handling program (see "Security" on page 2-36). The user profile function is only used if:

- The routing program is QCMD
- The TRFGRPJOB command transfers to QCMD

If a different program is used, you must specify the SETATNPGM command.

A new command, CHKRCDLCK, assists in group jobs (see "Group Jobs" on page 4-7).

See "Message Handling" on page 2-19 for a discussion of the user message queue.

See the group job discussion in "Emulation (3270)" on page 2-11.

Help

Help key: Most of the IBM displays now support the use of the Help key or F1 to access online help information.

Command support: The command prompter supports help information associated with the command and the parameters. This is limited to the OS/400 commands.

QHLPSYS library: The library QHLPSYS is supported differently than it was on System/38. The QHLPSYS library on the AS/400 system contains a new form of help information. QHLPSYS is shipped on the system portion of the library list to allow you to access this information.

Application help information: You may add help information to your applications by use of new DDS functions. Help information may be described in display files or by the use of the AS/400 Office text editor. For details, see Chapter 4, the *DDS Reference*, and the *Using OfficeVision/400* Word Processing*.

IBM-Supplied Programs

Supported programs: The following programs are supported and have no changes either in the function they perform or in the parameter lists required:

Scan for a string	QCLSCAN
Translation of data	QDCXLATE
Receive printer data	QMRSWTRG
Receive BSC printer data	QMRBSBSCI
Receive SNA printer data	QMRSSNAI
Receive from data queue	QRCVDTAQ
Materialize program	QSCMATPG
Create program from materialized version	QSCCRTPG
Send to data queue	QSNDDTAQ

GDDM also supplies programs that have not changed. See "Graphical Data Display Manager (GDDM)."

The following programs are supported, but use different names depending on which command syntax you are using:

System/38 Environment	OS/400 Program	Description
QCL	QCMD	Command entry
QCAEXEC	QCMDEXC	Execute a command from a string
QCACHECK	QCMDCHK	Validity check a command

The functions of QCMD have been enhanced over QCL (see "Sign-On" on page 2-45). The QCMDEXC and QCMDCHK functions are the same as the System/38 corresponding functions except they accept the OS/400 syntax.

If you have an HLL program to migrate from the System/38 to the AS/400 system that uses QCAEXEC with RCLRSC LVL(*CALLER), an error will occur because program files are closed. This happens because a change was made on the AS/400 system to ignore the QCAEXEC invocation when setting the reclaim level. To make your program run successfully, you must change RCLRSC to specify LVL(*).

For information on QPGMMENU see "Programmer Menu" on page 2-27.

Unsupported programs: The following programs are not supported (a not found message is sent if you call these programs):

System Operator menu	QOPRMENU
User menu	QCALLMENU

The new system menus may be used to replace these functions. If you have made significant use of either program, consider developing your own version.

Intersystem Communications Function

(ICF) Commands: The new ICF file is used by the OS/400 program to replace the BSC, MXD, and CMN file types. See "Data Description Specifications (DDS)" on page 4-4 for more information on these file types. New commands include:

Add ICF program device entry	ADDICFDEVE
Change ICF program device entry	CHGICFDEVE
Change ICF file	CHGICFF

Create ICF file	CRTICFF
Delete override ICF device entry	DLTOVRDEVE
Override ICF device entry	OVRICFDEVE
Override with ICF file	OVRICFF
Remove ICF device entry	RMVICFDEVE

For specific information see the online help information for each command.

Independent Work Station: This is now called PC Support/400. See "Intelligent Work Station Support 5714-PC1" on page 2-63.

Initial Program Load (IPL)

Attended versus unattended: The Start CPF display shown on System/38 following the IPL sign-on has been renamed to **IPL options**. One of the major reasons for presenting this display on each IPL of System/38 was to prompt the operator to enter the date and time. With the continuously powered clock on the AS/400 system, this step should be unnecessary for most IPLs. For this reason, a new system value exists (QIPLTYPE) that allows you to specify whether the IPL should be attended or unattended.

Unattended IPL is the default. This means that once you turn on the system, an operator is no longer needed. The controlling subsystem is automatically started and an automatic-start job can bring up the system and perform any unique requirements. See "Subsystem Description" on page 2-52 for the new support that assists in creating an automatic start job.

You can override the unattended default using the Manual keylock position on the operator control panel. This allows you to leave the default as unattended and still have an attended IPL for specific requirements.

The system also supports having the IPL occur at a specific time of day (see the QIPLDATTIM system value) or allowing a remote IPL (see the QRMTIPL system value).

One of the reasons to perform an attended IPL is to use the dedicated service tools (DST) function. Some functions (for example, disk device initialization) can only be done when the system is dedicated to the DST function. See "Service" on page 2-44 for more information about DST.

Another reason to perform an attended IPL is to access the IPL options from the OS/400 program. The OS/400 IPL Options display has been changed to allow some additional options:

- Start this device only. This allows the operator to do an IPL and directly enter the restricted condition. The restricted condition is used for such things as SAVSYS, RCLSTG, and the new RSTCFG command. On System/38, you had to start the system up and then work down to the restricted condition by ending the active subsystems.
- Start print writers option. This sets a system value that can be tested by a program. It is specifically provided to allow an automatic start job to start up the printers on the system. IBM provides a default automatic start job and makes it easier for you to provide your own solution. See "Subsystem Description" on page 2-52.

Frequency: On System/38, it was recommended that you perform an IPL frequently. On the AS/400 system you should not have to perform IPL as frequently. The system provides automatic cleanup of internal functions. However, there are functions performed by the system that occur at IPL and therefore a periodic IPL is recommended. See "Address Regeneration" on page 2-1 and "Programs" on page 4-12.

Configuration menu: The System/38 Configuration menu has been renamed to **Define or Change the System** at IPL. The number of valid commands that can be entered at this time has been increased.

Pool sizes and activity levels: A performance adjustment option exists that directs the system to adjust the storage pool sizes and activity levels at IPL time. See "Subsystem Description" on page 2-52.

System values: The system value QIPLSTS replaces QAUTOIMPL and may contain additional values to reflect which type of IPL has occurred (such as IPL at a time of day).

Console device: See "Console" on page 2-4 for how the system determines the console device.

Install: Install has two purposes:

- Installation of distribution media for the initial installation or a new release. If you selected the Total System Package (TSP) option (as described in Chapter 7), the software is already installed on your system and you do not need this step to migrate. If you do not select the TSP option, most countries (United States included) ship the system with the OS/400 program and the licensed internal code already loaded. If this does not occur, you need to install the OS/400 program and the licensed internal code.
- If you need to reload the entire system, install uses media that was sent by IBM or saved by the SAVSYS command on the OS/400 program. Install on the AS/400 system does not accept a tape or diskette saved from System/38.

Devices used: Only tape install (any tape model) is supported (no diskette). The function of writing a single diskette by SAVSYS (as on System/38) is not needed. The alternative IPL can occur directly from any tape device on the AS/400 system.

Primary language: If TSP is not used, one of the first prompts from the install process (follow the printed instructions) requests that you specify your primary language (for example, English, German, or French). The remainder of the installation process is done from menus and prompts that appear in your primary language. All menus include help information to assist in the installation.

System values and user profiles: Prompts are used to install system values and a command is used to restore user profiles. For the migration step, these functions are handled as part of the Migration Aid commands you need to use after installing the AS/400 programs.

It is possible to use the RSTUSRPRF command to restore user profiles from a tape created by the System/38 SAVSYS command. However, combining authorities (as described in "Security" on page 2-36) is only performed on a restore from media saved by the Migration Aid and only with the Migration Aid command on the AS/400 system.

Device configuration: A new OS/400 command (RSTCFG) is used to restore the AS/400 device configuration instead of using a prompt during the install process. This command cannot be used to restore the device configuration from a System/38 SAVSYS tape. Only the Migration Aid commands can migrate the device configuration objects. See "Device Configuration" on page 2-7.

Distributing licensed programs: The LICPGM (Work with Licensed Programs) menu or the new OS/400 SAVLICPGM and RSTLICPGM commands are intended for use by a central site for distributing code. The SAVLIB and RSTLIB commands should be used for backing up the licensed program libraries.

Jobs: The naming convention for jobs is the same for both the OS/400 program and the System/38 environment. A syntax change in OS/400 requires the job name be entered in the form JOBNBR/USER/JOB. See "Naming" on page 4-10.

A special routing entry is needed to use a System/38 job stream. See "Subsystem Description" on page 2-52.

Job Accounting: The job accounting journal is not migrated. You need to restore or create the accounting journal on the AS/400 system. See the *System/38 to AS/400 Migration Aid User's Guide and Reference* for more information and a sample program that could be used to move the job accounting journal to the AS/400 system. The Migration Aid migrates the QACGLVL system value. However, if the QACGJRN journal is not on the AS/400 system when the Migration Aid is run, the system value is set to *NONE.

Job Description

New parameters: New parameters in the job description object should not affect migration.

Default job description: A new default job description (QDFTJOB in QGPL) is used when user profiles are created. You may assign a specific JOB in the user profile as well.

Sign-on default: The default for the shipped subsystems is to use the job description of the user who signed on instead of the job

description with the same name as the subsystem (see "Subsystem Description" on page 2-52).

SBMJOB default: The default for the OS/400 SBMJOB command has changed to use the JOB in the user profile. The System/38 environment command uses the System/38 default QBATCH.

User profiles: See "Security" on page 2-36 for how migration handles the job description parameter in user profiles.

QSYSJOB: A new job description (QSYSJOB in QSYS) is used for backup purposes. It cannot be changed and you may temporarily use it if you have an unsupported job description. QSYSJOB is also implicitly used during a sign-on if the user's job description is not on the system.

Automatic startup job: A new job description (QSTRUPJD) allows a simpler approach to an automatic start job. See "Subsystem Description" on page 2-52 for a discussion on automatic start jobs.

Job Queue

Migration: The Migration Aid or save and restore migrates the object descriptions of job queues, but not the jobs on a job queue.

DSPJOBQ: New support on the DSPJOBQ command (WRKJOBQ in OS/400 environment) allows the user to change parameters for a job in a manner similar to the parameter line on the Output Queue display on System/38. In addition, a job can be placed at the top of the queue using the JOBPTY(0) value on CHGJOB.

Job priorities: New support with OS/400 environment commands allows a maximum-activity level setting per job priority on job queue entries. The function cannot be requested using the System/38 environment ADD/CHGJOBQE commands. The default of no maximum limit is used for each priority.

However, two differences are associated with this change:

- When the DSPSBSD display for job queue entries is displayed (in either case), you see the priority settings.

- The CHGJOBQE command can now be used (in either case) while the subsystem is active.

Job streams: No changes. The shipped subsystems provide a routing entry that is used by the JOB command to cause the system to check for System/38 environment syntax.

Journal: No changes. See “Job Accounting” on page 2-15.

Library

Migration: The Migration Aid does not migrate any libraries beginning with Q except for QGPL. If you have created libraries beginning with the letter Q or have objects or members in a library such as QRPG, you must migrate them using save and restore.

QSYS38 and QUSER38: Neither the QSYS38 nor QUSER38 libraries should be on your library list. If you run a program that has the System/38 attribute, the command analyzer uses these libraries first. See the discussion in “What Is the System/38 Environment?” on page 1-6 for more information about these libraries.

System values: The QSYSLIBL system value is shipped with these libraries:

```
QSYS
QUSRSYS
QHLPSYS
```

Current library: The user profile CURLIB parameter (as described in Chapter 1) defaults to *CRTDFT. This default does not change the library search list. The DSPLIBL command appears as it does on System/38.

The CURLIB parameter is specified in the user profile or on the OS/400 CHGLIBL or CHGCURLIB commands. There is no difference when using a System/38 environment CRT command versus the System/38 definition. The defaults for the CRT commands place the created object in QGPL. A difference occurs for

OS/400 CRT commands. The reason for the difference is the different defaults used on the create commands:

```
System/38 Environment  CRTCLPGM  PGM(xxx.QGPL)
OS/400                 CRTCLPGM  PGM(*CURLIB/xxx)
```

If the current library value contains a library name, the library search list is changed and the DSPLIBL display shows the current library name. Because many user CL statements specify an unqualified object name, the library list is used to find objects. Specifying a current library can cause a change in the library in which an object is found.

A library can be both the current library as well as somewhere else on the library list. It can be either on the system or user portion of the libraries. If the same library is in the user portion of the library list, it counts as one of the 25 libraries that make up that portion of the library list. If the current library is also one of the libraries in the system portion of the library list, then it counts as one of the 15 libraries in the system portion of the library list. If it is on the user portion, any search finds the object in the current library. See “Library” on page 4-9.

Product library: The PRDLIB parameter in command definition allows a command to specify that a library can be used during command processing. This library does not have to exist on the library list. If a *LIBL function is requested, it includes both the product library and the current library. This function is used by the IBM languages and utilities for both the System/38 environment and OS/400 commands.

To allow the full use of the product library concept, the command definition objects for the languages and utilities are now in the QSYS library as opposed to being in the product libraries, as they were on System/38. The installation process copies the command from the product library into QSYS. Two product libraries are supported by the system. You may only specify the first. The second is used for internal functions.

The following figures show the System/38 and the OS/400 program approaches to using a product library.

System/38 Approach

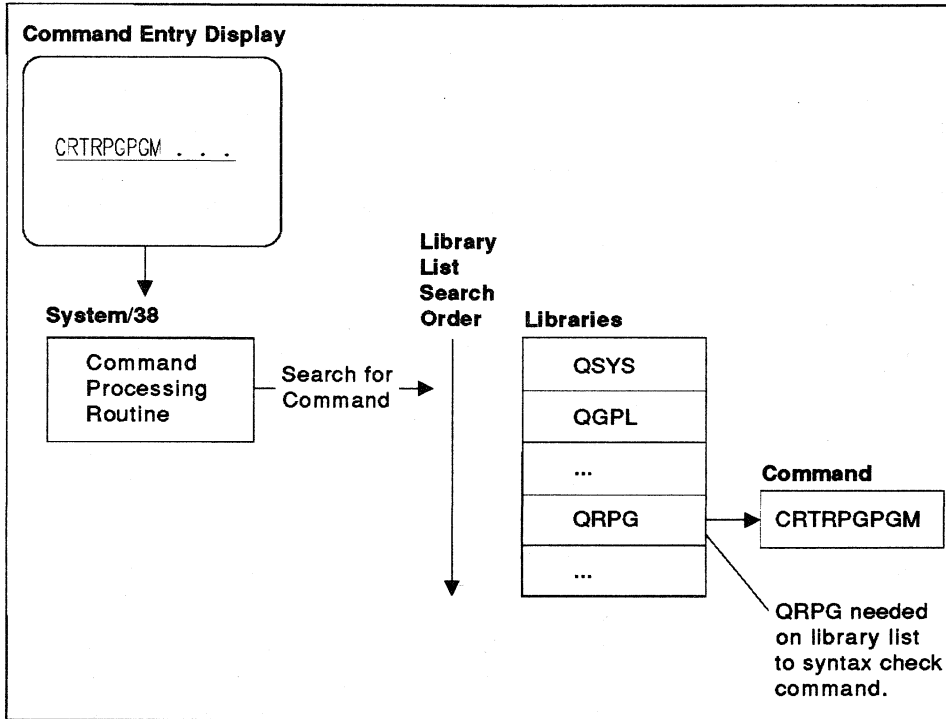

FV2W309-0

OS/400 Approach

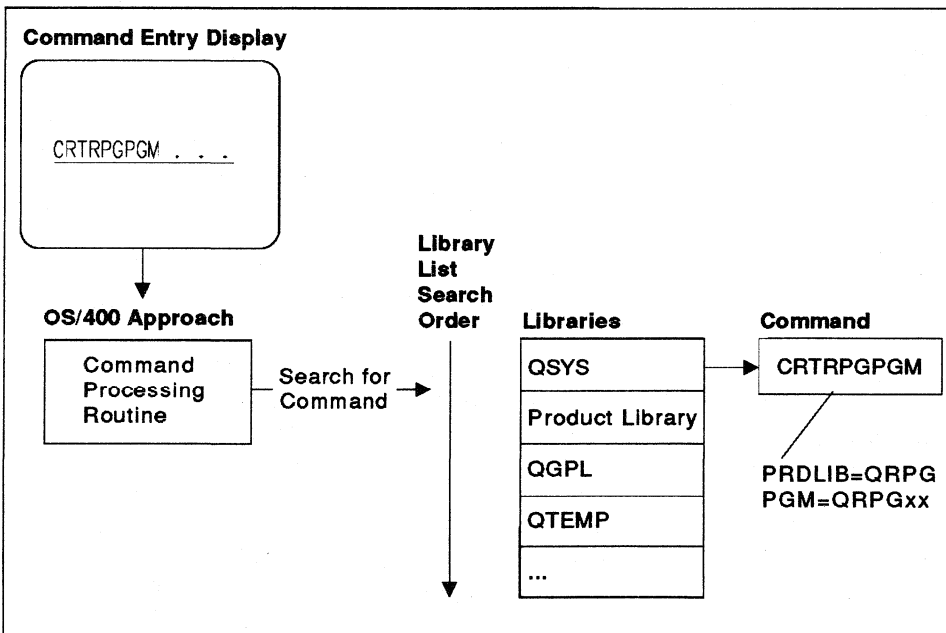

FV2W310-0

In the AS/400 approach, the CRTRPGPGM command exists in QSYS. Therefore, when the command is entered, it is found without requiring QRPGLIB to be on the library list. This allows the command to be checked for syntax.

Note: The command contains PRDLIB information as well as a command processing program. When the CRTRPGPGM command runs, it places QRPGLIB into the product library portion of the library list and then calls the command processing program. When the command completes, the QRPGLIB library is removed from the product library position.

The QRPGLIB library does not have to be on the library list for the SEU syntax check function or when the command runs.

The PRDLIB value is shown on the DSPLIBL display only if the command being used has specified a product library.

Changing profiles and commands: Both the current library and product library support allow you to name libraries that may already be on your library list. Therefore, you may begin to change user profiles and commands for this new support without making changes to existing job descriptions.

DSPOBJD outfile: The DSPOBJD outfile format has added additional fields on the end of the record. This should not cause changes to existing programs. The ODOBAT field, which defines the attribute of the object, contains the new values for System/38 attributes (for example, RPG38). See "Object Attributes and Source Types" on page 2-23. The ODOBTP field has a change for one value. See "Cross-Reference" on page 2-5 for more information about this field.

Delete options: DSPOBJD and DSPLIB in the OS/400 program does not support option 9 (Delete) to delete objects. The new OS/400 command WRKOBJ allows the delete option.

Renaming: A library cannot be renamed (RNMOBJ) if it contains a journal, journal receiver, or the new IDDU dictionary object.

Logs

QCHG: The system log QCHG is no longer supported. This log on System/38 was devoted to programming changes. The AS/400 system changes are called programming temporary fixes (PTF). The PTFs are now logged to QHST. See "Programming Temporary Fix (PTF)" on page 2-28.

QSRV: The system log QSRV is no longer supported. A similar function is available in the problem log (see "Problem Log" on page 2-27).

LU-1: The logical unit-1 (LU-1) support is less restrictive with request unit lengths. Device configuration changes are required. See the new commands described in "Device Configuration" on page 2-7. "Data Description Specifications (DDS)" on page 2-6 describes the CMNF file.

Menu

Commands: The DSPMNU command is not supported. It is replaced with the GO command, which has a similar function, but only identifies the OS/400 commands. No support displays the System/38 environment commands in a manner similar to the DSPMNU command. However, the commands WRKCMD (work with command) and SLTCMD (select command) can be used to select System/38 commands.

The GO command displays:

- Any of the new IBM menus (for example, the System Main Menu) designed to assist in operating the system. A list is displayed if a generic name is entered.
- The new command-grouping menus, which replace the functions performed by DSPMNU on System/38.
- User menus, which are defined as *MENU object types. This is a new function and is described in "Menu" on page 4-10.

The GO command allows you to display immediately a menu that is a menu object. For example, the System menu QSYS/MAIN is the default assigned as the initial menu for any created profiles. To immediately access this menu, you would specify:

```
GO          MAIN
or GO      MENU(MAIN)
```

To provide a function similar to the System/38 DSPMNU capability, OS/400 commands have been placed in menu objects and given names that begin with the 3-character abbreviation CMD. These are known as command grouping menus. The following shows a comparison to access the commands that have JOB in their names:

System/38	DSPMNU	MENU(JOB)
OS/400	GO	MENU(CMDJOB)

To work with the new CMDxxx menu objects, the command grouping menus have been changed as follows:

- F16 to run a command without prompts is not supported from the menu.
- Help information is available for the commands.
- A command line (entry of a full command) exists on all command menus. No special input fields are given for a command name or menu name.
- Certain functions are AS/400 system only. For example, the displays that allow a parameter line on System/38 allow a similar function on the AS/400 system, but the entries must appear in OS/400 syntax. For example, the DSPOUTQ function to change a spooled file to a different output queue must be specified in OS/400 syntax such as OUTQ(LIBX/OUTQB).

Command entry capability: On System/38, very few displays supported command entry capability (for example, the Command Entry display and the Programmer Menu). On the AS/400 system almost all of the OS/400 menus support the ability to enter a command on a command line. Only OS/400 syntax is supported on AS/400 menus.

You can control whether a user has the general capability of entering commands. If you are relying on menus to provide security, you want to use the LMTCPB parameter in the user profile (see "Security" on page 2-36).

Unsupported menus: QCALLMENU is not supported. This menu was the default for the QUSER profile and allowed a simple method of calling programs. It would be possible to build your own version to simulate the System/38-provided version.

QOPRMENU is not supported. This menu was the default for the QSYSOPR profile and allowed easy access to system operator functions. New system menus are provided to help operate the system.

Other menus: See "Programmer Menu" on page 2-27 for a discussion of the changes to the Programmer Menu.

See "System Request" on page 2-55 for a discussion of the changes to the System Request menu.

The Configuration Menu at the OS/400 IPL Options display has been renamed and enhanced. See "Initial Program Load (IPL)" on page 2-13.

Message Handling

Migration: The Migration Aid or save and restore function migrates message queue object descriptions, but not any messages in the queues. Message file objects and message descriptions are migrated. The System Reply list cannot be saved and must be manually updated.

Message IDs: Most message IDs remain the same, including the CPFxxxx types. In most cases, programs monitoring for escape messages should not have to change. A few message IDs that are sent to QSYSOPR have been changed.

A valid message description ID includes the characters A to F (in addition to 0 to 9) for the last 4 characters (for example, CPFAABB). Some messages issued by IBM use this expanded naming function. The System/38 environment commands can work with this expanded definition.

User profile message queue: A message queue is associated with each user profile on the AS/400 system. The default when a user profile is created is to create a message queue with the same name as the user profile in the QUSRSYS library. The OS/400 commands allow a special entry on SNDMSG, SNDUSRMSG, and SNDPGMMSG to send directly to the message queue associated with the user profile. The System/38 environment commands do not allow easy use of these message queues. However,

you can achieve somewhat the same function in the System/38 environment using RTVUSRPRF to access the MSGQ associated with the user profile and then specifying the retrieved name on the SND commands.

The DSPMSG command in either case displays both the work station message queue (if any messages exist) and the user message queue as the default. If you do not want the user message queue function, you could change the default of the DSPMSG command.

The user message queue is automatically transferred on group job transfers (TFRGRPJOB command). If the same user also signs on a secondary job (using TFRSECJOB), the user message queue is also transferred.

The user message queue should become the preferred method of sending messages to users. For example, the SND commands allow you to communicate to a user name that is generally more descriptive than a typical work station name. System support also relies on the fact that a message queue is associated with each user profile. You may want to take advantage of this support. If you have already created unique user message queues, but have not specified the name in the user profile MSGQ parameter, you should consider making the change.

Two new user profile parameters, DLVRY and SEV, allow you to specify the initial setting of the user message queue. These values are copied into the job attributes and can be changed during the job. See the *CL Reference* manual for details on these parameters.

The CRTMSGQ command parameter for SENDER is ignored in the System/38 environment command. All message queues (including those migrated from System/38) are the equivalent of SENDER(*JOB *PGM *DTS). On the OS/400 program, addition of the sender information increases the message length by approximately 50 characters. You may need to increase the size of your message queue.

The error messages sent to the QSYSOPR message queue messages, the 2-byte error code has changed to a 4-byte code and will change in some cases. For communications the hardware error code values are changed.

QSYSMSGQ: If you are using QSYSMSGQ on System/38, you need to re-create QSYSMSGQ on the AS/400 system. See the *System/38 to AS/400 Migration Aid User's Guide and Reference* for more information and a sample program that could be used to move the user message queue (QSYSMSG) to the AS/400 system.

QSYSOPR: The QSYSOPR user profile is set to MSGQ(QSYS/QSYSOPR), DLVRY(*BREAK), and SEV(30). This places the normal QSYSOPR message queue in break mode when QSYSOPR signs on and avoids having two QSYSOPR message queues on the system. This differs from System/38 where the queue is not automatically placed in break mode whenever the operator signs on (except if QSYSOPR does an IPL).

If your System/38 approach was to have an initial program for QSYSOPR that placed the queue in break mode and established the severity setting, you should see no change. You may want to change the initial program so that the system support can be used.

All the other shipped IBM user profiles provide the MSGQ parameter default which creates a message queue in QUSRSYS (for example, QUSRSYS/QPGMR).

Message text: All system message text appears in OS/400 form. For example, a typical qualified name is described in the message text as 0BJX in LIBY. The message data format (for example, MSGDTA parameter on RCVMSG) remains either the same as on System/38 or is compatible for most message IDs.

For example, the message description for CPC2191 on System/38 appears as:

```
MSG('Object &1.&2 type &3 deleted.')
```

The replacement values are defined as:

```
&1 Object name      *CHAR LEN(10)
&2 Library name     *CHAR LEN(10)
&3 Object type      *CHAR LEN(7)
```

To send the message, the SNDPGMMSG command would be used to identify the message ID (CPC2191), the message file (QCPFMSG) and the message data, which contains the replacement values to be substituted into the message text. The message data would be defined as 27 bytes (the sum of the lengths described for the

substitution values). Assume that the message data contains:

```
'OBJX      LIBY      *JOBBD  '
```

When the message is shown on System/38, it would read as:

```
'Object OBJX.LIBY type *JOBBD deleted.'
```

The message on the AS/400 system is written as:

```
MSG('Object &1 in &2 type &3 deleted')
```

The SNDPGMMSG command would not change nor the formatting of the MSGDTA parameter. The message is shown as:

```
'Object OBJX in LIBY type *JOBBD deleted'
```

The RCVMSG command allows MSGDTA to be retrieved and it would receive the same format as on System/38. For this reason, most programs which send and receive IBM messages using the message data do not need to be changed.

However, if a program scans the message text itself (for example, by use of the MSG parameter on RCVMSG) there will be a difference. The program could be searching for a qualified name in the message text by scanning for a period on System/38. If this is the case, a change would be required. This is also true for programs that scan message text within the history log.

Messages Guide: The *System/38 Messages Guide*, SC21-7736, for System/38 is no longer published. The message text and the format of the message data can be found in the online display of messages. The descriptive wording of the substitution values in the message data is not included. In most cases, the content of the substitution values is obvious by looking at the message text. If you frequently used the substitution values descriptions in the *System/38 Messages Guide*, you should probably keep the manual.

Changing message descriptions: The OS/400 WRKMSGD command retrieves the message description information and places the existing values in the command prompt for the CHGMSGD command. This simplifies changing existing message text.

Message displays: The display of first-level messages changes so that all impromptu messages are identified as to who sent them, date sent, and time sent. An additional line is shown for impromptu messages.

The second-level message display changes significantly:

- A reply for an inquiry message can be specified on the second-level message text display (shown by pressing the Help key).
- Formatting of some messages occurs to include blank lines and indentation. This significantly improves the readability of the messages.

You can change your own message text to include the new formatting characters. See the ADDMSGD and CHGMSGD commands in the online help information.

Certain messages allow access to the problem analysis function for problem determination. See "Problem Analysis Function" on page 2-26.

PDPCODE and LOG keywords: The Problem Determination (PDP) codes assigned to messages have been removed. The function has been replaced by a combination of improved message text and the problem analysis function. The LOG function for logging messages to QSRV is no longer supported. The PDPCODE and LOG keywords remain on the RTVMSG and RCVMSG commands in the System/38 environment, but blanks are returned. The corresponding keywords are ignored on the ADDMSGD and CHGMSGD commands. See "Service" on page 2-44 for more information on unsupported functions.

Inquiry messages: When an interactive job issues an inquiry message to a message queue, and the reply is not implicitly made (for example, if the queue is in default mode or the system reply list is used), a status message is sent to the work station informing the user that his job is waiting for a response.

For example, assume you are using a save command interactively. During the running of the command, an inquiry message concerning the media may be sent to QSYSOPR message queue. No feedback is sent to your work station on System/38 that your job is waiting for a response. On the AS/400 system, you receive a

message informing you that your job is waiting for a reply to a message sent to QSYSOPR.

QSYSOPRDEV system value: The QSYSOPRDEV system value is no longer supported. The system value named a message queue that was sent a message if QSYSOPR was not allocated when a message was received in QSYSOPR.

Personal computers as work stations: A special type of device description, *PEER, can be configured for a *PCS device that is attached to an IBM Token-Ring Network. This implicitly creates a message queue in QUSRSYS in the same manner as created for local work stations. Sending messages to all work stations includes these message queues.

Logs: The QCHG and QSRV logs are no longer supported. See "Logs" on page 2-18.

Mixed File: See "Data Description Specifications (DDS)" on page 2-6.

Naming

Syntax: While operating in the System/38 environment, the names you can specify for object names, job names, or field names are unchanged. Qualified names can be entered as they were on System/38. If commands are entered in the OS/400 program, differences in terms of syntax, the separator character, valid characters, and quoted names exist. In the System/38 environment, use of the extended names as defined for the AS/400 system is not valid. See Chapter 4 of this manual for more information. The *CL Programmer's Guide* contains more information about name syntax.

User assigned names: Documents on System/38 did not have user-assigned names. On the AS/400 system, the names can be assigned in the same style as PC names.

Network Attributes: None of the network attributes on System/38 are migrated by the Migration Aid to the AS/400 system. For non-alert attributes, see the *System/38 to AS/400 Migration Aid User's Guide and Reference* for more information and a sample program.

Alerts: The network attributes for alerts have changed significantly. If you are using alerts, you need to review the new definition before you make any entries (see "Alerts" on page 2-1). The *Alerts and DSNX Guide* contains more information.

If you are not using alerts, you may continue to take the defaults.

Commands: The System/38 environment commands that work with network attributes continue to function for some network attributes. However, you should use the OS/400 commands to enter and change these attributes because only the OS/400 commands support the full function.

Attributes: The following describes each of the System/38 network attributes and any changes that have occurred:

ALRSTS	A new value (*UNATTEND) is supported, but only on the OS/400 command.
ALRCTLU	This is renamed to ALRCTLD in the OS/400 program. Any use on the RTV or CHG commands causes an error message.
ALRFOCPNT	Not supported. Any use on the RTV or CHG commands causes an error message.
SYSNAM	This is renamed to SYSNAME in the OS/400 program. SYSNAM performed two functions on System/38: <ul style="list-style-type: none">• Name on the displays. This operates the same as it did on System/38.• Means of establishing communications with another system. This function has changed. See "Remote Location Name (RMTLOCNAME)" on page 2-28.

The display, change, and retrieve functions that use the SYSNAM parameter in the System/38 environment all operate on the OS/400 program. SYSNAME attribute.

The following network attributes have the same definition as in System/38:

Network

Attribute	Description
MSGQ	Message Queue
OUTQ	Output Queue
JOBACN	Job Accounting
MAXHOP	Maximum number in SNADS network
DDMACC	DDM Access

The following are examples of new network attributes. For a complete list and detailed descriptions of all network attributes, see the *Work Management Guide*.

Network

Attribute	Description
LCLNETID	Local network ID
LCLCPNAME	Local control point name
LCLLOCNAME	Default local location name
DFTMODE	Default mode name
MAXLOCCNV	Maximum number of conversations for remote location
NODETYPE	Node type
MAXINTSSN	Maximum number of intermediate sessions
RAR	Route addition resistance
NETSERVER	Network node servers
ALRPRIFP	Alert primary focal point
ALRDFTFP	Alert default focal point
ALRLOGSTS	Alert logging status
PCSACC	PC Support

Object Attributes and Source Types: On System/38, the source type you entered for SEU was used to determine the syntax checking routine that should be used. In most cases, the source type became the source type associated with the source member. It could be displayed with DSPFD and appeared in the DSPFD outfiles. In some cases the same type was used in the object form as the object attribute if you created an object from the source. The object attribute could be seen by such commands as DSPOBJD and in the outfiles associated with several commands.

On the AS/400 system, the support is changing. The source types that represent the System/38 environment have a 38 added to the end of the type. Also, some source types are valid only in

the System/38 environment. In the OS/400 program, there are also unique source types. In addition, the object attributes are being changed on the OS/400 program so they more closely match the source types.

Restore of System/38 objects: When a program object is restored from System/38 to the AS/400 system, the system changes the attribute to indicate that it is a System/38 type.

When a file object is restored from System/38 to the AS/400 system, the system determines if the object was directly created from source. If source was used, a 38 is added to the end of the attribute.

For example, if you created a physical file from DDS source on System/38, the attribute would be changed from PF to PF38 when restored to the AS/400 system. If you created a physical file without using source (for example, you used the RCDLEN parameter), the attribute would be PF when restored to the AS/400 system.

Object attribute: For files, the object attribute is only an indication of the type of source used. For programs, the attribute also indicates how the program is run.

The object attribute can be used to assist you in determining how the object was created. In terms of running the program, it makes little difference. For example:

- A System/38 environment or an OS/400 program can access either a System/38 environment or an OS/400 file. In fact, both files could be accessed in the same program.
- A System/38 environment or an OS/400 program can call either a System/38 environment program or an OS/400 program. In fact, both could be called from the same program.

The following chart describes the attributes used by the System/38 environment and the OS/400 program. The System/38 environment and OS/400 columns are for both source type and object attribute unless described in the notes.

Note: New source types exist other than those shown.

Description	System/38 Source Type	System/38 Object Attribute	System/38 Environment Source Type and Object Attribute	OS/400 Source Type and Object Attribute	Notes
CL Program	CLP	CL	CLP38	CLP	
CL Job Stream	CL		CL38	CL	1
Command Definition	CMD			CMD	2
Physical File	PF	PHY	PF38	PF	
Logical File	LF	LGL	LF38	LF	
Display File	DSPF	DSP	DSPF38	DSPF	
Printer File	PRTF	PRT	PRTF38	PRTF	
ICF File				ICFF	3
Mixed File	MXDF	MXD	MXDF38		3
BSC File	BSCF	BSC	BSCF38		3
Communication File	CMNF	CMN	CMNF38		3
RPG	RPG	RPG	RPG38	RPG	
RPG Auto Report	RPG	RPG	RPG38	RPG	4
COBOL	CBL	CBL	CBL38	CBL	
PL/I	PLI	PLI	PLI38	PLI	
BASIC	BAS	BAS	BAS38	BAS	
BASIC Procedure	BASP	BASP	BASP38	BASP	5
PASCAL		PAS		PAS	6
AS/400 DFU				DFU	7
AS/400 Query				QRYDFN	7
System/38 DFU	DFU	DFU EXC DFU NOTEXC	DFUEXC DFUNOTEXC		8
System/38 Query	QRY	QRY EXC QRY NOTEXC	QRYEXC QRYNOTEXC		8
Text	TXT		TXT	TXT	9

Notes:

1. There is no object form of a CL job stream.
2. Command definition source is OS/400 program only. The command definition object does not have an object attribute. Additional function exists on the OS/400 program. In most cases, no change is required from System/38. See "Command Definition" on page 2-2.
3. Mixed, BSC, and communication files can only be created in the System/38 environment. In the OS/400 program, the ICF file should be used.
4. On System/38, the entry of RPT is only used on the Programmer Menu. If SEU is requested, the type is converted to RPG. The RPG/400* syntax checker for SEU operates on either RPG or Auto Report source (it is valid to key unique Auto Report syntax into RPG source, but it is rejected by the CRTRPGPGM command). The special entry of RPT is used by the Programmer Menu

when the create option is specified to submit the CRTRPTPGM command. The object attribute is RPG. No source members have an RPT source type. The object attribute is always RPG.

In the System/38 environment, the definition is similar except that RPT38 is used, instead of RPT on the Programmer Menu and on the programming development manager.

For the OS/400 program, the entry of RPT is used to specify that the AS/400 CRTRPTPGM command should be used. The source member type is RPT instead of RPG. The CRTRPTPGM command issues a warning message if the source type is not RPT.

5. There is no object attribute for a BASIC procedure.
6. PASCAL is a PRPQ on System/38 and is not supported by SEU as a special type. PASCAL is a licensed program on the AS/400 system and is fully supported.

7. The System/38 DFU and Query products exist only in the System/38 environment. Different products of the same name exist for the AS/400 system. There is no source type for OS/400 products.
8. The System/38 DFU and Query products exist only in the System/38 environment. Different products of the same name exist in the OS/400 program. The System/38 environment source type is DFU38 or QRY38. As shown in the chart, the System/38 object attribute is changed when restored on the AS/400 system so the blank is removed from the attribute. If you have programs that are sensitive to the object attribute, they must be changed.
9. The TXT attribute is used on source members only (it is not an object attribute). The source member types are identical in both the System/38 environment and the OS/400 program. This tells SEU not to perform any syntax checking. The TXT source member attribute is not changed when a source member is restored from System/38. There is no object form of text source. The System/38 compatibility text management function on the AS/400 system creates members with a TXT38 type.

Object Distribution: See Chapter 5.

Object Types: The PRTIMG object type is not supported.

*CUD on System/38 has been changed to *CTLD on the OS/400 program.

The *SPADCT object type remains, but has a new internal definition. Because of the new internal design, CRTDUPOBJ can no longer be used on a *SPADCT object type. New object types are provided. The following is a list of some of the new object types. See the *Programming Reference Summary* for a complete list.

Authorization list	*AUTL
Configuration list	*CFGL
Class-of-service description	*COSD
Data dictionary	*DTADCT
Folder	*FLR
Ideographic sort table	*IGCSRT

Menu definition	*MENU
Mode description	*MODD
Panel group	*PNLGRP
Product definition	*PRDDFN
AS/400 Query definition	*QRYDFN
Reference code translate table	*RCT
System/36 machine description	*S36
Information search index	*SCHIDX

Outfiles: Several DSP commands support the OUTFILE parameter to allow a database file to be created. See the individual sections for changes in this area such as “Library” on page 2-16, “Cross-Reference” on page 2-5, and “Security” on page 2-36.

See “Out Files” on page 4-11, for the enhancement being made to the OUTMBR parameter.

Output Queue: See “Spool” on page 2-48. The Migration Aid or save and restore migrate the output queue object descriptions, but not any of the spooled files.

Overrides: OVRCRDF is not supported. See “Printers” on page 2-26 for changes relative to print images.

The OVRDBF values of SEQONLY and INHWRT are be operational for the OPNQRYF command. The SEQONLY parameter on OPNQRYF is overridden by the OVRDBF value if it exists.

Pass-Through: For 3270 pass-through, see “Emulation (3270)” on page 2-11.

For 5250 pass-through, no changes have been made to the support provided by the BGNPASTHR command. As on System/38, all sessions use the first mode defined in the list of modes associated with each device specified on the BGBPASTHR command. You should ensure that each first mode has enough session and conversation resources defined to support pass-through and any other applications that use that mode.

*PASS control units are called virtual controllers on the AS/400 system.

PC Support: See “Intelligent Work Station Support 5714-PC1” on page 2-63.

Performance Information

CSNAP: No CSNAP function exists. Some of the same function can be achieved using the device configuration THRESHOLD parameter.

System/38 Performance Tools PRPQ: Many of the data collection functions performed by the System/38 performance tools PRPQ (5799-BJK) have been incorporated into the OS/400 program. The analysis functions have been changed, but essentially the same support exists in the Performance Tools Licensed Program. See "Performance Tools PRPQ 5799-BJK" on page 2-64.

Printers

Supported printers: Only work station printers can be used on the AS/400 system. No system-attached printers are supported. The following are not supported:

- 5211
- 3262
- 3203
- 4245 Models 12 and 20

The 4245 Models T12 and T20 are supported.

The DBCS printers 5224 Model 11 and 5225 Models 11 and 12 are not supported.

File keywords: The printer file PRTIMG and TRNTBL keywords are not operational on the AS/400 system and are ignored for the System/38 environment. These keywords are only associated with system attached printers and are ignored in the System/38 environment. The support is deleted because it only applies to system attached printers.

Printer device naming: The QDEVNAMING system value controls the name of the default printer device. The special value *DEVADR from this system value causes the system to derive a device name from the resource name for a device description that is being created.

MAXRCDS error: If the number of records in a print file is exceeded (MAXRCDS parameter), an inquiry message is shown and the operator is allowed to continue. If the number is exceeded during an interactive job, the end user receives the message. If the number is exceeded during

a batch job, the message is sent to the QSYSOPR message queue.

References: See also "Return Codes" on page 2-35, "Data Description Specifications (DDS)" on page 2-6, and "Spool" on page 2-48.

Problem Analysis Function: The problem analysis function is used for problem analysis of hardware and software errors. When an error occurs, the message indicates if the problem analysis function may be accessed. The problem analysis function assists in capturing the information and analyzing the problem. A detailed description is available in the *Operator's Guide*.

When a user perceives an error, the Analyze Problem (ANZPRB) command is used to assist in determining the nature of the problem.

Problem Determination

Copying screen images of another work station: A significant new function exists to allow authorized individuals to copy the display image of another user. This enables you to follow the flow of what users see so you can assist them in understanding the problem. This same function can also be used by IBM support personnel to assist in analyzing system problems. See the online help information for the STRCPYSCN command.

Displaying database file records: AS/400 Query supports a command, RUNQRY, that can be very useful in problem determination. It allows any externally described database file to be displayed without creating a Query first. Prompts for selection specifications are available with the command. A single display of information is accessed and shown. The columns of information are placed in a variable display; windows can be used to see any particular field (no folding occurs).

Spooled files: The new WRKSPLF command allows several options, one of which displays all the spooled files associated with a specific user. Displaying the spooled file attributes also includes the date and time the file was created and the program that created the file. The program name is shown only if a HLL program was created on the AS/400 system (not restored from System/38).

Problem Log: All problems perceived by the system are placed in the problem log. Each problem is identified and tracked. Problems found by the user are also placed in the log. The *Operator's Guide* contains more information. See also "Problem Determination."

Programs: The OS/400 create program commands support a significant new function for replacing programs. See "Programs" on page 4-12. The System/38 environment commands implicitly use REPLACE(*NO).

To successfully migrate an object program to the OS/400 program, the program must include the program template. PASCAL programs must be re-created from source on the AS/400 system. See "Save and Restore" on page 2-35 for a complete discussion.

See "Debug" on page 2-7 and "Return Codes" on page 2-35.

Programmer Menu

PDM: A programming development manager (PDM) has been added. This is part of the Application Development Tools Licensed Program. It has similar functions to the System/38 Programmer Menu as well as new support. PDM allows you to work with lists of libraries, objects, and members and offers convenient options. User options can also be added.

Programmer Menu: The Programmer Menu has been changed. The display is shown in Chapter 1. Only an OS/400 version of the Programmer Menu exists. The command entry line only supports commands using OS/400 syntax. However, you can work with either System/38 environment or OS/400 source types. See "Object Attributes and Source Types" on page 2-23 and "Utilities and Other Licensed Programs" on page 2-61. Changes to the Programmer Menu include:

- The format of the display differs, but the main functions are included. Function key changes exist.
- The TEXT parameter has been removed. The major reason for this entry was to allow the text to be entered on a create command. The default for the TEXT parameter was

changed during the System/38 releases to specify the source member description as the default. The source member description can be entered when SEU is exited or through the SEU Member List display.

- F11 operates differently on OS/400 program types. See the discussion on the REPLACE option on "Programs."
- The Log requests option has been dropped. (Requests are always logged.) Logged requests are now in a form to be operable again from command entry (except if an exit program is used).
- A new default exists for job description (*USRPRF - User Profile).
- The default for object library remains blank. System/38 creates are placed in QGPL and OS/400 program creates are placed in *CURLIB. *CURLIB may also be specified (see "Library" on page 2-16).
- F6 (display messages) operates differently to allow both the work station message queue and the user profile message queue to be displayed. See "Message Handling" on page 2-19.
- The EXITPGM parameter list has changed:
 - The TYPE parameter is now a *CHAR 10 field.
 - The LOGRQS parameter is not supported (logging is always active).
 - The Object library parameter may reflect *CURLIB.
 - The Job description parameter may reflect *USRPRF.
 - The TEXT parameter is not supported.
- The OS/400 DFU and Query entries ignore any parameter entries on the display. The initial menu for these functions are called.
- The System/38 environment DFU and Query products cannot be accessed from the display except by entering a command such as:
QSYS38/DSNDFUAPP

Programming Change: This is now referred to as a programming temporary fix (PTF) on the AS/400 system. See "Programming Temporary Fix (PTF)" on page 2-28 for more information.

Programming Temporary Fix (PTF): This was known as a Programming Change (PC) on System/38. The System/38 commands cannot be used in either the System/38 environment or the OS/400 program. The new commands (for example, LODPTF) support all of the licensed programs, OS/400 program, and the licensed internal code. The *Operator's Guide* contains more information.

Unattended apply: A new option exists on APYPTF to allow you to automatically apply delayed PTFs at the next unattended IPL. This allows OS/400 and licensed internal code PTFs to be applied without operator intervention.

Electronic distribution: A new command (CPYPTF) allows PTFs to be packaged for electronic distribution to remote sites. PTFs may also be sent using tape or diskette.

Prompter

Format: A single command prompter on the system is used for both the System/38 environment and the OS/400 program. See "Command Definition" on page 2-2.

The prompter has two forms:

- No keywords are shown, but keyword descriptions and allowed values are shown.
- Keywords and descriptions are shown, but not the allowed values.

You may switch back and forth between the two forms with a function key. A user profile parameter controls which form is displayed first. See the user profile USROPT keyword and use the *CLKWD entry to show the keyword form first.

Prompts with incorrect information: Prompts have changed to ignore incorrect keywords or values. As long as a valid command name has been specified, the command prompt is shown. A warning message is displayed if any keywords or values have been dropped from the command string.

Layered prompt: Layered prompt support exists. This means that a set of keywords is shown for a command and, based on the values entered, the user is directed to other keywords. If an entry on a display makes a subsequent

parameter meaningless, the subsequent parameter is not displayed.

The System/38 environment commands do not support this function. It is possible to add the support to any command and have it run either in the System/38 environment or the OS/400 program.

RA/DHCF: No changes from System/38.

Recovery

Automatic licensed internal code completion: The automatic licensed internal code completion function (following a disk device failure where no data loss occurred) is not supported. The system performs a shutdown function that attempts to minimize recovery at the next IPL (sometimes this was referred to as **Subset Recovery** on System/38).

Forced licensed internal code completion: The forced licensed internal code completion function is still supported. It requires a special entry on the operator control panel. Diskettes are not used. The *Operator's Guide* contains more information.

References: See also "Checksums" on page 2-2, "Uninterruptible Power Supply" on page 2-59, and "Save and Restore" on page 2-35.

Remote Location Name

(RMTLOCNAME): The AS/400 system uses a different mechanism than System/38 for identifying the remote system for communications support. On System/38, you indicate the remote system by the name of a device description. For example, you specify the DEV parameter on the CRTCMNF command when you create a communications file. On the AS/400 system, you identify the remote system by a remote location name. For example, you specify the RMTLOCNAME parameter on the ADDICFDEVE command when you define a device for an ICF file.

The RMTLOCNAME is defined when you create a device description for a communications device. Given a RMTLOCNAME, the system can determine which device to use to get to the remote system.

Your System/38 applications that use the System/38 environment BSCF38, CMNF38, or MXDF38 file types do not need to be changed because of the switch to RMTLOCNAME. These file types do not support the RMTLOCNAME interface.

You should be aware of how RMTLOCNAME functions relate to the System/38 way of describing remote systems.

- The RMTLOCNAME support is a more flexible approach to networking requirements, and you may want to migrate to this support.
- AS/400 functions, such as advanced peer-to-peer networking (APPN), are available only if you use the RMTLOCNAME support.
- Certain system functions, such as SNADS, exist for which there is no System/38 environment-specific support. OS/400 SNADS uses the new RMTLOCNAME support instead of the device description name in the Next System Table. Even if you are using SNADS in the System/38 environment, you are indirectly using the RMTLOCNAME support.

The rest of this section shows how RMTLOCNAME relates to the System/38 configuration and illustrates some of the functions available through it. The first example shows an advanced program-to-program communications (APPC) APPN configuration. Also included is an example of the other communications types use of RMTLOCNAME.

System/38 APPC approach: On System/38, the device description object contains two important entries:

- | | |
|-------|--|
| RMTLU | The logical name of the system to communicate to (the remote system) |
| LCLLU | The logical name of your system (the local system) |

The LCLLU entry uses *SYS as the default, which means network attribute SYSNAM is used on System/38. However, you could use any name

to describe your own system. Allowing any name makes it possible for your local system to be known by several names.

Figure 2-1 and Figure 2-2 show different approaches to device description objects.

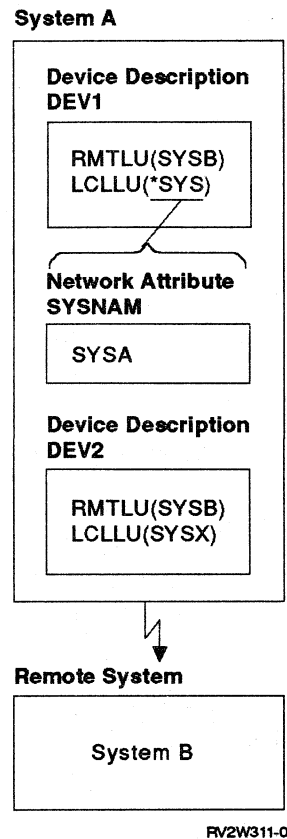
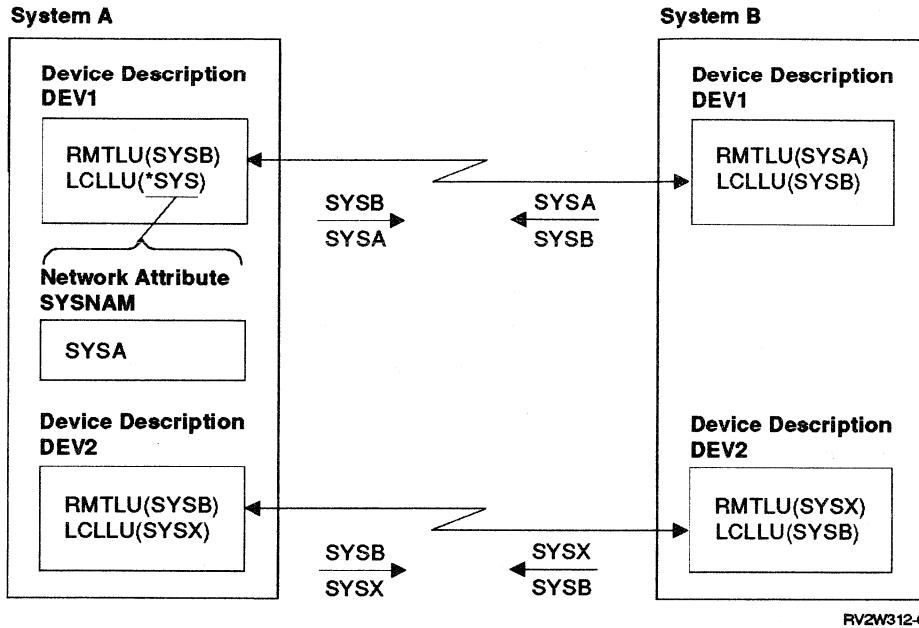

Figure 2-1. System/38 APPC Approach to Device Description Objects

In this example, your local system is known by either the name SYSA or SYSX. The advantage of being able to specify an additional name is that it allows more flexibility to move functions from one system to another within a network, without making changes each time a function is performed on a different system.

When an APPC communications link is established, both names are sent to the other system, which must respond with a matching set.



RV2W312-0

Figure 2-2. Using Multiple Device Descriptions When Using APPC

Prior to establishing communications to another system, both systems had to create the device description objects to allow the link to occur. It is not necessary that the device descriptions have the same names.

Parameters: In the OS/400 program, the names of the parameters have changed, but they essentially have the same meaning:

System/38		AS/400 Names
RMTLU	→	RMTLOCNAME
LCLLU	→	LCLLOCNAME

The LCLLU parameter has a different default. It is now *NETATR. This refers to the new network attribute LCLLOCNAME. Thus, the same concept of having a default is allowed, but more flexibility exists to separate the functions performed by the System/38 network attribute of SYSNAM (the other function causes the name to be used on displays). If you do not need this flexibility, you should use the same name for both network attributes.

On the OS/400 program, a new object called a configuration list is used if you are using APPN. You can identify the additional names that you

want to call your own system (all of the local LU names that you want your system to be known as). These are the local names. You use the CRTCFGL, CHGCFGL, ADDCFGLE, and RMVCFGLE commands to maintain this list. A sample list might look as follows:

Configuration List

SYSA
SYSX
JOE
PAYROLL

RV2W313-0

Additional names for APPC local names are determined the same as before with the local location name in the device description. APPN additional names are defined in the APPN local location configuration list.

The OS/400 program supports the capability of dynamically creating device descriptions. For example, Figure 2-3 shows a request being received from another system as follows:

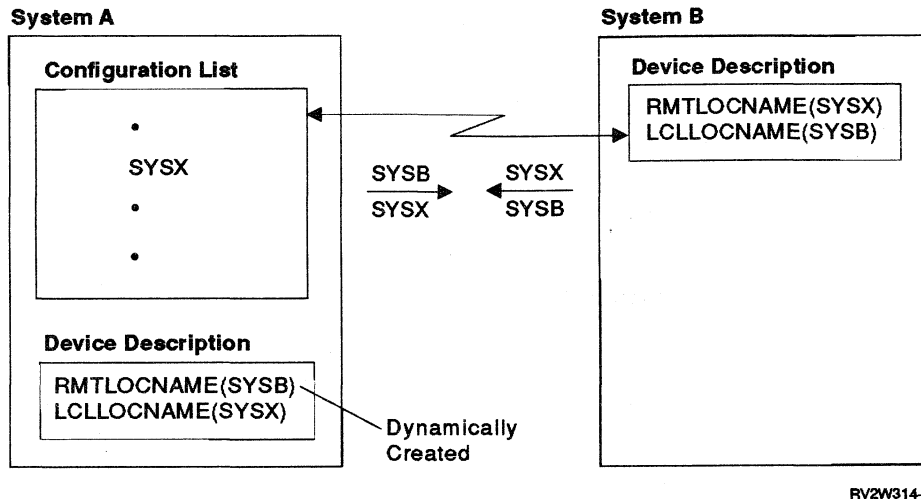

Figure 2-3. Dynamically Creating Device Descriptions

The local AS/400 system knows that the communications request is for this system because the name SYSX is in the APPN local-location configuration list. If a device description with the specified RMTLOCNAME and LCLLOCNAME exists, it is used. If not, a device description is dynamically created.

The system builds an internal directory of the RMTLOCNAME and LCLLOCNAME information from created device descriptions. This directory is searched to determine if a device description already exists and if so, it is used.

Another way the system dynamically creates a device description is when a program opens an ICF file. In the System/38 environment, the files used by application programs must specify a device description that has already been created. However, OS/400 files require that RMTLOCNAME be specified instead of a device description and the device description object can be implicitly created.

When you define the configuration link in an ICF file, you need only describe a RMTLOCNAME.

The RMTLOCNAME is a parameter on the ADDICFDEVE or OVRICFDEVE command. The device description object is dynamically selected for you when the file is opened. The LCLLOCNAME uses the default network attribute *NETATR.

Any dynamically created device description acts the same as a user-created device description on the system. For example, you may change or display the device description. If you no longer need one of the descriptions, you must delete it. The system does not keep track of which device descriptions are being used. If you accidentally delete one that is being used, the system dynamically creates it again when it is needed.

In the first example on dynamically creating a device description (Figure 2-3), a request came in from SYSB and it identified that it wanted to talk to SYSX. The local system found the SYSX name in the APPN local-location configuration list and, therefore, it created a device description to be used.

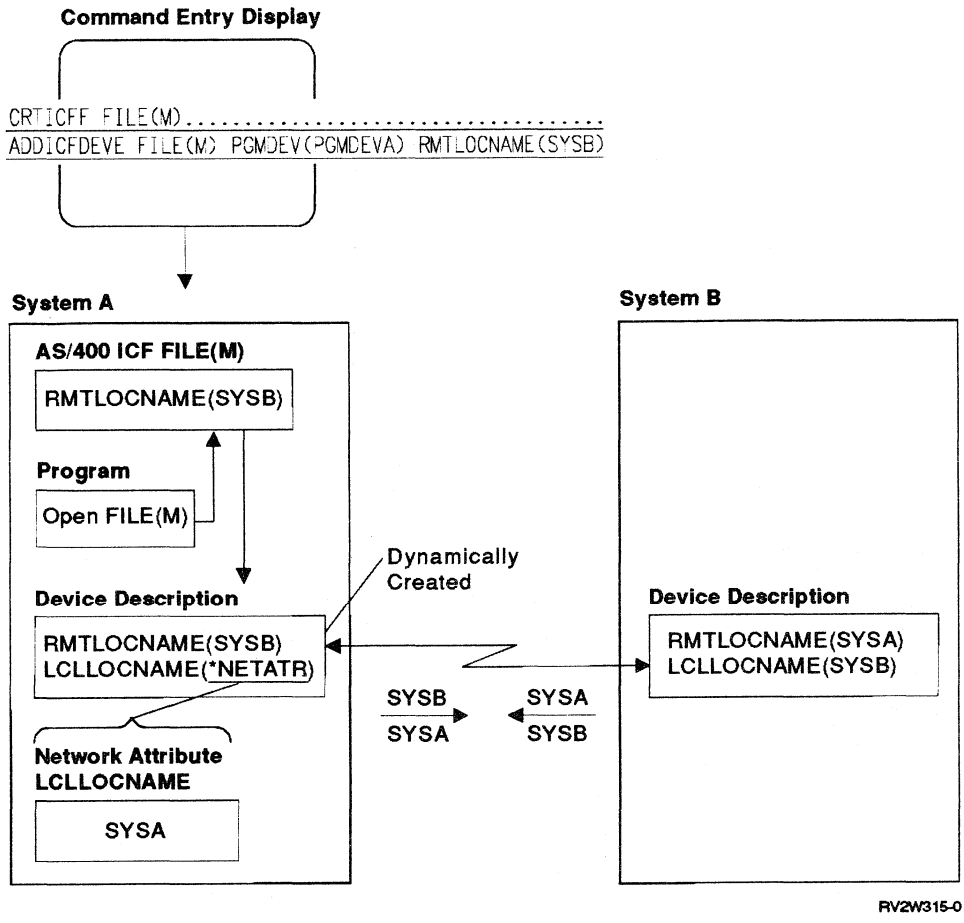

Figure 2-4. Using a Dynamically Created Device Description

If the name is not in the list, is not the default local location name in network attributes, and is not the local control point name in network attributes, the new system support for APPN is used automatically.

For example, assume a request came in for SYSZ. This is not in the local list so the new APPN support would search an internal table (directory). The table is updated implicitly by the system. This table contains the actual location of where the name exists (which system calls itself by that name). A table might look like:

RMTLOCNAME	Remote Control Point
BILLING	SYS2
MARY	SYS5
SYSB	SYS5
SYSZ	SYS2
TOM	SYS7

The system would find SYSZ in the directory and route the request to SYS2. APPN also automatically determines how to route the request. For example, the system determines which lines to use and which intermediate systems must be sent for the request to have it forwarded. This is based on the class-of-service object associated with the mode. The class-of-service object associated with the mode defines the acceptable ranges of link and node characteristics for the session. The request for SYS2 may have to be routed to SYS7 first, no physical connection exists between your system and SYS2.

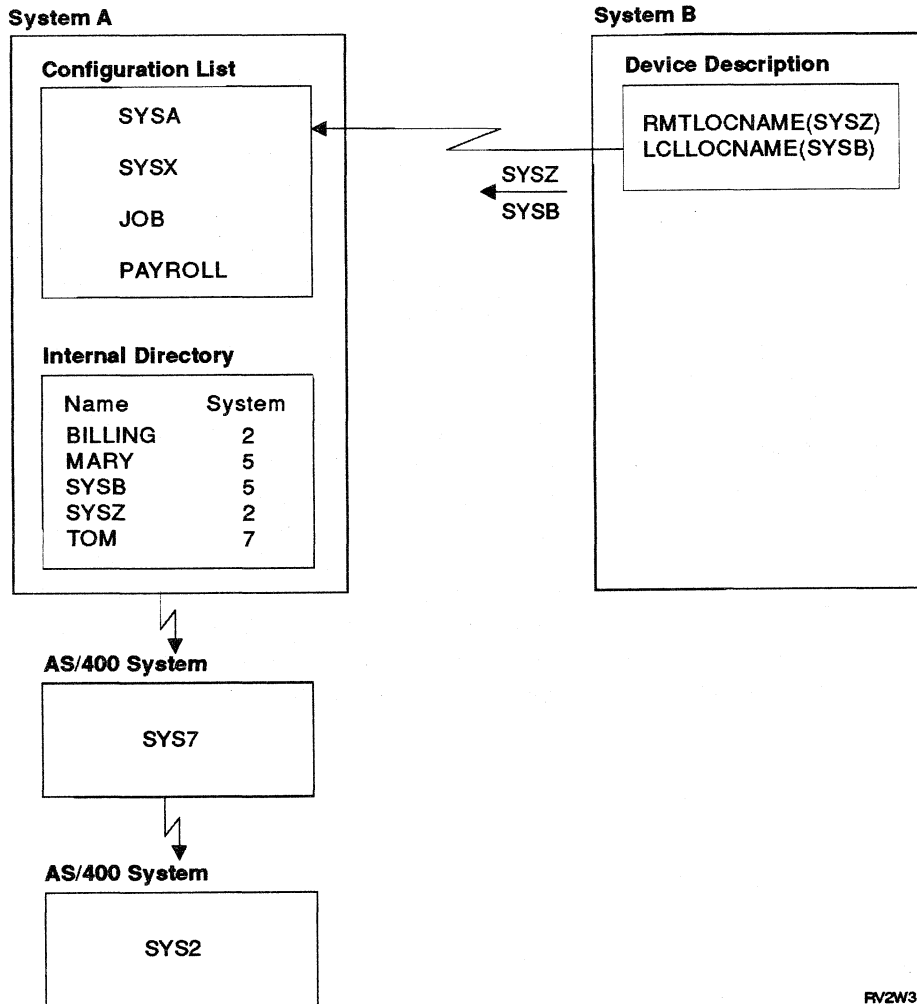

RV2W316-0

The directory keeps track of where it finds the names. Each system in the network has a directory performing a similar function.

Assume now that a request comes in from System B for a RMTLOCNAME = SAM. SAM is not in the APPN local-location configuration list so the system knows the request cannot be met locally. It passes the name to the remote directory function, which does not find the name either. The remote directory then sends a broadcast message to every system in the network to see if SAM exists. The following can result:

- No system has SAM as a name, and therefore the original request is rejected.
- One system responds saying it is known (or also known) as SAM. In this case, the directory is updated and the request sent to the responding system.

- More than one system responds as SAM. The first system to respond is assumed to be the correct system and is forwarded the request, but an error is posted. You must manage the network in terms of keeping the names unique across the network.

The directory is a dynamic function. For example, in the previous discussion BILLING is on SYS2. BILLING may represent one or more database files and programs. Assume a change is required to move the entire function to SYS7. Our system has a directory entry for BILLING that points to SYS2. If a request for this occurs, our system directs it to SYS2. SYS2 responds, saying it does not have BILLING. Our system deletes the entry from the internal table and broadcasts a message to all systems saying Who has BILLING? When SYS7 responds, the table is updated.

The same concept of RMTLOCNAME is also used for other communications functions (for example, BSC and asynchronous). You must name a RMTLOCNAME, but for non-APPC devices you must also create a device description. The device description you create describes a RMTLOCNAME only to identify the device description to be used. The LCLLOCNAME should not be used for a non-APPC device (the entry is ignored).

For non-APPC devices, the RMT and LCL names are not sent to the other system. Only the APPC protocol sends the RMT and LCL names. For non-APPC protocols, the RMTLOCNAME is used only to determine which device description to use. Figure 2-5 shows what happens when non-APPC devices are used.

The advantages of the new support include:

- You do not have to have a direct line connection to the systems with which you want

to communicate. The system manages that task for you.

- You do not have to create as many objects to communicate.
- You can assign meaningful names to functions you want performed. If you want to change which system handles an application such as payroll, you would just delete it from one system and restore it to another system. The configuration list on both systems must reflect which names (for example, application functions) they support.
- Other communications functions on the AS/400 system also take advantage of the RMTLOCNAME concept, including the SNA Upline Facility (SNUF) and device emulation. In SNUF and device emulation, the use of a remote location name allows the system to select the first available device description if more than one device description contains the same remote location name.

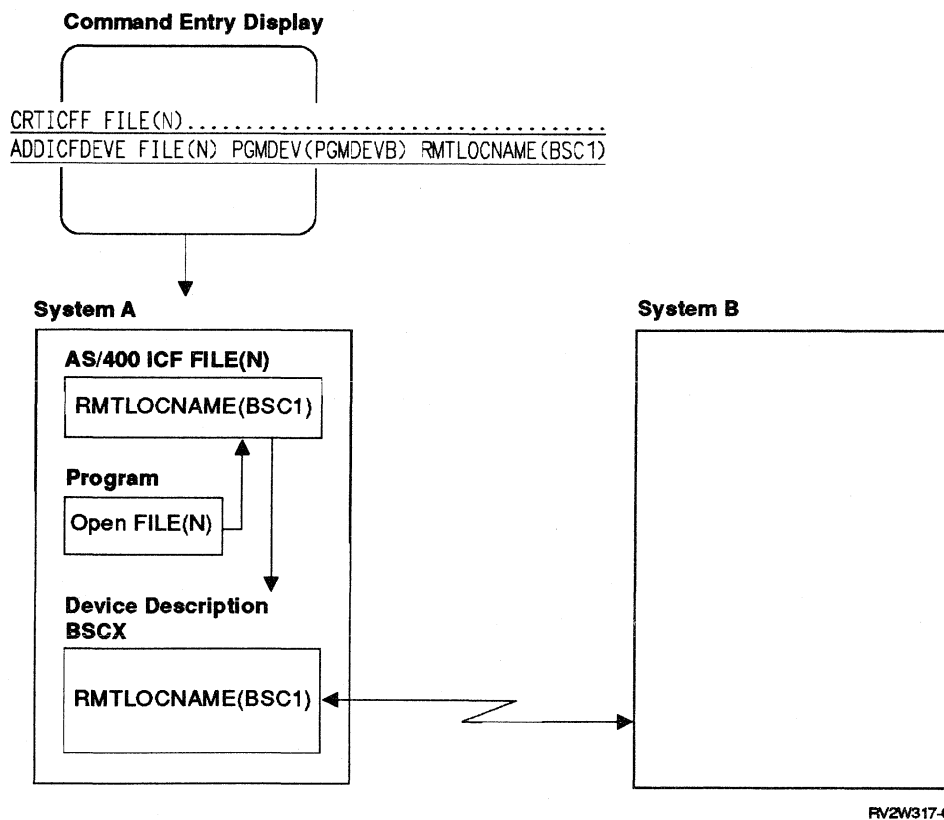

Figure 2-5. Non-APPC Communications

Return Codes

BSCF, CMNF, and MXDF: The System/38 file types of BSCF and CMNF use the same return codes as on System/38.

The MXDF-type uses return codes associated with the type of device. The return codes associated with BSC, LU-1, and APPC devices remain the same. The return codes associated with displays have changed.

Display and printer files: The return codes for DSPF and PRTF have changes. The changes are primarily to agree with the same codes used in the OS/400 program. Many applications do not check for the return codes for displays or printers. The major return codes are primarily identical (most changes affect the minor return codes). The changes are described in Appendix C.

Cancel job: The 02 major return code is set if a cancel job (called **ending a job** in the OS/400 program) is requested. This does not affect printers, BSC, or CMN files. MXD files are not affected except for display functions. The 02 major return code does not cause an escape message. If your program is performing an action and the major return code is not 00, you may need to change your program.

Save Files: The object descriptions of the save files will migrate successfully using the Migration Aid or save and restore. However, any contents in a save file are not migrated. You must use the SAVSAVFDTA command to save the contents of a save file.

Save and Restore

Program objects: Program objects are converted to a new internal format when they are restored. This is an automatic function, but requires a longer restore time. The translation process is dependent on information that System/38 stores with the program (the information is called the **program template**). System/38 always creates a program with the program template.

There is no support using System/38 CPF to remove the program template, but some non-IBM software can remove program templates. If you have removed the program tem-

plate, the program is not restored on the AS/400 system and you need the source to create the program again. The restore command fails if it cannot convert the program. The remaining objects for the same command are also not restored.

CL programs are converted to the new format regardless of how the RTVCLSRC parameter was specified. (It is not necessary to have retrievable source to restore a System/38 CL program.)

Licensed programs: Programs from the System/38 licensed programs (for example, the RPG compiler) are not restored on the AS/400 system. You must obtain the OS/400 licensed program.

RSTPGMPRD is now RSTLICPGM.

Note: The utilities provided with the Migration Aid should be used whenever possible.

Release requirements: The AS/400 system supports most object types saved on System/38 Release 5 or later (both diskette and tape). If you have historical data that you may want to restore on the AS/400 system, you must ensure that it was saved on System/38 using Release 5 or a later release. You should also ensure that it is saved on a media format and type density that can be restored on the AS/400 system.

Tape: The tape devices supported by the AS/400 system are all supported by save and restore. For tape capacities, rates, and devices supported for models of the AS/400 system see "Tape" on page 2-58.

Only a tape device (not diskette) is supported for SAVSYS. When tape is used, a diskette is not output as it is on System/38. The diskette was needed on System/38 because the IPL for installing could only occur from diskette.

Diskette magazine device: No diskette magazine device exists. A single-slot diskette device is optional and is supported by save and restore. See "Diskette" on page 2-10.

Interchange between System/38 and the AS/400 system: When the System/38 objects are restored on the AS/400 system, the attributes of programs are changed to be System/38. File objects are also changed if created from source.

Source types are also changed for source members. See "Object Attributes and Source Types" on page 2-23.

An object cannot be saved from the AS/400 system and restored on System/38. Data interchange only exists from the AS/400 system to System/38. This is true regardless of whether the object is a System/38 environment object or an AS/400 object. (See the discussion in Chapter 5.)

Most object types can be saved from System/38 and restored on the AS/400 system. *PRTIMG object types saved on System/38 cannot be restored on the AS/400 system.

Some device files saved on System/38 with attributes that are not valid are not restored by the OS/400 restore. Examples include card files and display, mixed, or communications files with unsupported DDS functions. See "Data Description Specifications (DDS)" on page 2-6 and the *System/38 to AS/400 Migration Aid User's Guide and Reference* for more information.

Documents and folders: The SAVDOC and RSTDLOC commands do not operate in either the System/38 environment or the OS/400 program. The OS/400 commands are SAVDLO and RSTDLO. RSTDLO cannot be used to restore a *DOC object from System/38. AS/400 documents saved by SAVDLO cannot be restored on System/38.

The Migration Aid can be used to migrate documents to the AS/400 system.

A Personal Services/38 user can mail a document to a user on the AS/400 system. The AS/400 user could file the document in a folder. (A folder is used to group related documents and to find documents by name. It is similar to a library.)

The new SAVDLO command can save specific folders and documents while other work is occurring on the system. However, if you request that all documents and folders be saved, the restricted condition (all active subsystems ended) must be used.

SAVSYS: The SAVSYS command saves both QSYS and related OS/400 objects (as it did on System/38). On the AS/400 system (using either

the System/38 environment or the OS/400 command), SAVSYS also saves the licensed internal code. Two licensed internal code areas on the AS/400 system allow for permanent and temporarily applied PTFs. This allows a better recovery process as any PTFs that you have applied to the licensed internal code are saved so you can easily restore the current system. SAVSYS saves both areas if any PTFs are only applied temporarily.

New object types: The System/38 environment commands do not allow the specification of the new object types (for example, *MENU). However, a generic request (for example, SAVLIB) saves all of the object types.

Security considerations: On System/38, if a new object was restored and the owner did not exist on the system, the owner was changed to QSECOFR. On the AS/400 system, the owner name is QDFTOWN.

The RSTUSRPRF command on the OS/400 program can be used on SAVSYS media created from System/38, but only if saved on Release 8.

Database files: A change has been made to the way database files are restored on the system. On System/38, spreading on different disk actuators did not occur for files less than 16 megabytes. On the AS/400 system, better spreading occurs if the space utilization of the disk units is approximately the same. The technique approximates what would happen if you created a new file and used a program to write records to the file. If you add a new disk unit, spreading will not occur until the new disk unit has approximately the same amount of space utilization as the existing units.

Security

Levels: Three different security levels exist and are controlled by the system value QSECURITY:

- Level 10 No password. All users have essentially all authority. A few functions are reserved for the security officer and service profiles.
- Level 20 Password is required. All users have essentially all authority. A few functions are reserved for the security officer and service profiles. It is pos-

sible to constrain the user to user-written menus.

Level 30 Password is required. Object level authority is enforced.

Level 30 is similar to the type of security on System/38. Level 30 specifies that you require passwords to sign on and that users can only do what they are authorized to do.

The default value is level 10 and you may want to change to level 30 to achieve the same type of support as existed on System/38.

Single-level sign-on: No support exists for the System/38 option of single-level sign-on (password only). Users must enter both their user name and a password to sign on. See "Sign-On" on page 2-45.

User profile: The user profile has significant changes from System/38. There are additional parameters, different defaults, and different intent for some parameters. The Migration Aid primarily converts the existing attributes. It does not attempt to take advantage of new support.

The Migration Aid does not migrate the IBM-supplied user profiles. Any authorities that existed for the IBM-supplied user profiles are not migrated. See Chapter 7 for suggestions on the IBM profiles.

The CRTUSRPRF command in the System/38 environment does not have the new parameters. If you issue CRTUSRPRF in the System/38 environment you will see some differences from the OS/400 CRTUSRPRF command.

Read the parameters described next to decide on your strategy. You may want to use the OS/400 CRTUSRPRF command for entering new profiles and the OS/400 CHGUSRPRF command to change existing profiles after migration.

Existing System/38 keywords: The following table shows System/38 keywords, the defaults in the System/38 environment and the OS/400 program, and information about what happens during migration. (New keywords also exist. See the *CL Reference* and the *Security Concepts and Planning* manuals for a complete list of the new keywords.)

Figure 2-6 (Page 1 of 3). Existing System/38 Keywords

Keyword	S/38 Environment Default	OS/400 Program Default	Migration Notes
USRPRF	Required	Required	No changes.
PASSWORD	Required	Required	The password that was on System/38 is converted. If it was not encrypted on System/38 (single-level sign-on was used), it is encrypted on the AS/400 system (the user password does not change even though it is stored differently on the system). The default passwords assigned to the IBM supplied profiles now begin with a Q. For example, the default password for QSECOFR is QSECOFR.
MAXSTG	*NOMAX	*NOMAX	The current value is migrated from System/38. The meaning differs on the AS/400 system. On System/38, the office objects did not contribute to the user's total. On the AS/400 system, the office objects are owned by individual users and contribute to the total.
PTYLMT	5	3	The current value is migrated from System/38. The IBM-supplied profiles that had PTYLMT 3 or less are changed to 0. This allows the new function of being able to move jobs on job queues to the top of the queue. You need to consider a 0 value for those profiles that you want to have the same capability. The same function exists for output queues (see "Spool" on page 2-48), but the OUTPTY parameter accepts only 1 to 9.

Figure 2-6 (Page 2 of 3). Existing System/38 Keywords

Keyword	S/38 Environment Default	OS/400 Program Default	Migration Notes
SPCAUT	*NONE	*USRCLS	<p>SPCAUT. The current value is migrated from System/38. System/38 supports *SAVSYS, *JOBCTL, and *ADMIN. The *ADMIN function becomes *SECADM on the AS/400 system and differs in that users with this authority can only change user profiles that they are authorized to change (for example, those the user created). *ADMIN still exists on the System/38 environment command, but it is displayed and retrieved as *SECADM.</p> <p>The new special authorities are *ALLOBJ, *SERVICE, and *SPLCTL. The *ALLOBJ authority is the same function the security officer uses to work with any object on the system. The *SERVICE authority is necessary to perform certain service functions. The *SPLCTL authority allows the user to work with any spooled file on the system.</p> <p>The default is *USRCLS, which refers to the USRCLS parameter.</p> <p>The QSECOFR profile is shipped with all the special authorities. The QSRV profile is shipped with the *SERVICE authority. The QSYSOPR and QPGMR profiles remain as they were shipped on System/38.</p>
INLPGM	*NONE	*NONE	<p>The current value is migrated from System/38. Assuming the defaults are taken on System/38, a change occurs if the initial program does a return. On System/38, the Command Entry was shown. On the AS/400 system, the INLMNU parameter is tested. See "Sign-On" on page 2-45.</p>
JOB	QDFTJOB	QGPL/QDFTJOB	<p>If the System/38 value is other than *NONE, the value is migrated from System/38. If *NONE exists, then the AS/400 default of QDFTJOB in QGPL is used. The intent of this parameter changes so that it becomes the base for attributes to be established for the user's job.</p> <p>If you use the CRTUSRPRF command in the System/38 environment, a JOB(*NONE) entry is translated to QGPL/QDFTJOB.</p>
GRPPRF	*NONE	*NONE	No changes. The current value is migrated from System/38.
OWNER	*USRPRF	*USRPRF	No changes. The current value is migrated from System/38.
GRPAUT	*NONE	*NONE	No changes. The current value is migrated from System/38.
ACGCDE	*BLANK	*BLANK	No changes. The current value is migrated from System/38.
DOCPWD	*NONE	*NONE	This is the document password used for office documents. The current value is migrated from System/38.

Figure 2-6 (Page 3 of 3). Existing System/38 Keywords

Keyword	S/38 Environment Default	OS/400 Program Default	Migration Notes
MSGQ	*USRPRF	*USRPRF	<p>If the System/38 value is other than *NONE, the value is migrated from System/38. If *NONE exists or the System/38 environment CHGUSRPRF command is issued and specifies *NONE, then the OS/400 default of *USRPRF is used. This creates a message queue in QUSRSYS with the same name as the user profile. The intent of this support has significantly changed, as described in "Message Handling" on page 2-19. The message queue defined should be for the majority of messages that are sent to the user.</p> <p>If you use the CRTUSRPRF command in the System/38 environment, a *NONE value is translated as *USRPRF. See also the new parameters of DLVRY and SEV.</p>
OUTQ	*DEV	*DEV	<p>If the System/38 value is other than *NONE, the value is migrated from System/38. If *NONE exists, then a default of QPRINT in QGPL is used.</p> <p>The intent of this support has significantly changed, as described in "Spool" on page 2-48. The default allows users to be able to easily direct all of their output to a specific printer. If you already have output queues associated with individual users or you do not print all of the spooled output, this value should be set to the desired queue.</p> <p>If you use the CRTUSRPRF or CHGUSRPRF command in the System/38 environment, a *NONE entry is translated to *DEV.</p> <p>Spool operations specify different defaults on the AS/400 system. The default is to the system printer (see "Spool" on page 2-48). If you want a specific output queue to be used as the default, you should specify the queue in the user profile. Note that the Migration Aid will change all of the *NONE values to QPRINT. This allows all of the migrated profiles to operate as they did on System/38.</p>
PUBAUT	*NONE	*EXCLUDE	<p>The current value is migrated from System/38. The Migration Aid combines the public authorities with the private authorities as described later in this section. The name of the PUBAUT parameter changes to AUT for all of the CRT commands in the OS/400 program, and the values that may be entered change. The System/38 environment supports the System/38 keyword name and values.</p>
TEXT	*BLANK	*BLANK	<p>No changes. The current value is migrated from System/38.</p>

Checking authorization: Authorization differs significantly on the AS/400 system in that it is no longer additive. For example, on System/38 the authority to an object was the sum of the following authorities to the object:

- Public authority
- Private authorities
- Group authorities
- Program adopt authorities

On the AS/400 system, a check is made for an individual authorization. If found, the authority is then checked and no further checking occurs. The following sequence is used:

- *ALLOBJ authority (new special user profile authority)
- Private authority to the object
- Private authority in authorization list (new function to allow multiple objects to be secured by a common list of users and their authorities)
- ALLOBJ authority for the group profile
- Group profile private authority to the object
- Group profile private authority using authorization list
- Public authority to the object
- Public authority in the authorization list

Program adopt authority remains additive (it accumulates all the authorities from each adopted program and adds them to the user's authority). As on System/38, if the owner of the program being adopted is a member of a group profile, the group profile's authorities are not considered. Only the owner's authorities are added for as many programs as are active in the program stack that adopt authorities.

To better understand the differences, assume the following authority to a file object is displayed using DSPOBJAUT on System/38:

USER NAME	OBJECT RIGHTS			DATA RIGHTS			
	OPER	MGT	EXIST	READ	ADD	UPD	DLT
*PUBLIC	X			X		X	
JONES	X				X		
GROUPA	X						X

Assume JONES is a member of GROUPA. On System/38, JONES can process the file with all data authorities. JONES is specifically given the add authority. He uses the public authority to gain the read and update authorities. He uses

the group authority (GROUPA) to gain the delete authority.

On the AS/400 system, if the object authority looked just like this, JONES would not have the authority to read, update, or delete records in the file because he has a specific authority. The public and group authorities would not be added.

The Migration Aid must be used to migrate the user profiles before any other objects are migrated. The restore of user profiles saved by the Migration Aid causes the public authorities and group authorities to be added to the individual authorities, which would look as follows on the AS/400 system:

User	Object Authority	---Object---			-----Data-----			
		Obj	Mgt	Exist	Read	Add	Upd	Del
*PUBLIC	*USE	X			X		X	
JONES	*CHANGE	X			X	X	X	X
GROUPA	USER DEF	X			X		X	X

Note: The authorities for both JONES and GROUPA have been changed during migration.

Assume JOHNSON is a member of GROUPA. He has the same authority that he had on System/38 and will not see any difference on the AS/400 system.

Assume SMITH is not a member of GROUPA. SMITH is not specifically authorized to the object and continues to operate using the *PUBLIC authority. He will not see any difference on the AS/400 system.

In most cases, when you begin processing on the AS/400 system, you will not see a difference in authority checking because of the changes that occur when user profiles are restored using the Migration Aid. However, as you change authorities, you must take into consideration that OS/400 authorities are not additive. If you have programs that grant and revoke authorities, you may need to make changes to achieve the same function.

Only the Migration Aid performs the function of adding the public and group authorities. The RSTUSRPRF command can be used to restore user profiles from System/38 SAVSYS media. However, only media from Release 8 can be used.

Object authorities: The System/38 environment commands (for example, GRTOBJAUT) continue to allow parameter entries such as *NORMAL and *OPER. When the user grants or revokes *NORMAL in the System/38 environment, *OBJOPR, and all four data authorities are granted or revoked. When *OPER is granted or revoked, *OBJOPR and *READ are granted or revoked.

Most of the OS/400 commands have changed as follows:

System/38 Environment	OS/400 Program
*NORMAL	*CHANGE
*OPER	*USE
*NONE	*EXCLUDE
—	*OBJOPR

The *OBJOPR right is new for the OS/400 program and sets only the operational right for an object.

The OS/400 CRT commands now use the keyword AUT instead of PUBAUT. Most of the CRT commands default to *CHANGE. See the *Security Concepts and Planning* for the details.

When you use DSPOBJAUT, you only see the OS/400 terminology if it can be used (for example, if the combination of authorities translates to *CHANGE). If the authorities cannot be translated to a descriptive word, the word is shown as *USER DEF* (user defined).

You can see the Xs displayed by the System/38 DSPOBJAUT command by pressing F11. You can switch back and forth between the descriptive wording and a display that has both the descriptive wording and the Xs. Also, a user profile option controls whether you first see the descriptive wording like *USE or the display with both the wording and the Xs. See the user profile parameter USROPT and specify *EXPERT to see the System/38 Xs first.

The display with both types of entries is shown similar to the following:

User	Object Authority	----Object----			-----Data-----			
		Opr	Mgt	Exist	Read	Add	Upd	Dlt
JONES	*CHANGE	X			X	X	X	X
*PUBLIC	*USE	X			X			

The term *USE normally indicates that the object can be read only (not changed).

Excluding a user: On the AS/400 system, new support has been added for exclusion of a user. The *EXCLUDE authority means the user cannot access the object. For example, if the display appears as:

User	Object Authority	----Object----			-----Data-----			
		Opr	Mgt	Exist	Read	Add	Upd	Dlt
JONES	*EXCLUDE							
*PUBLIC	*USE	X				X		

The user JONES cannot access the object.

Note: Even though the public can read the object, JONES cannot. You cannot mix any of the other authorities with the *EXCLUDE authority for a single user.

The *EXCLUDE right is significantly different from revoking all authorities for a user on System/38. If the user's rights are totally removed on System/38, the user's name is removed from the display and the user can access the object using the public authorities. On the OS/400 program, the *EXCLUDE entry remains and the user cannot access the object.

The *EXCLUDE authority differs for public authorization (the *PUBLIC user) versus individual users as follows:

- For the *PUBLIC user, the *EXCLUDE authority can be set in either the System/38 environment or the OS/400 program. If you specify PUBAUT(*NONE) in the System/38 environment, you set the *PUBLIC authority to *EXCLUDE. If you specify RVKOBJAUT AUT(*ALL) or remove all the authorities, you set the *EXCLUDE authority.

When objects that have no *PUBLIC authority are converted from System/38, they are shown on the AS/400 system with the *EXCLUDE authority set.

- For individual users, no method exists in the System/38 environment to set the *EXCLUDE authority. You must use the OS/400 EDTOBJAUT or GRTOBJAUT command.

The *PUBLIC user cannot be removed from the authorization to an object. It must be given some authorities or be excluded.

An individual profile or group profile can have private authorities, be excluded, or have no authorities. If the profile has no authorities, the user has public authority (or the group's authorities, if the group has authorities).

For individual user profiles (not *PUBLIC), you now have a choice of explicitly authorizing users or explicitly excluding them. You need to decide on a strategy to follow. If you use *EXCLUDE, you must be careful when you add a new user profile that objects that should not be accessible to the new user profile are excluded.

One of the advantages of *EXCLUDE is that you may have you want to control differently. For example, the a group user group is able to access an object, but a specific member of the group is excluded. If you use this approach, you must consider how to handle a new user profile being added to the group.

Changing authorities: The DSPOBJAUT command (in either the System/38 environment or the OS/400 program) only shows the authorities and does not allow any changes. The EDTOBJAUT command (OS/400 program only) provides a similar function to allow changes like that for the System/38 DSPOBJAUT command. However, the EDTOBJAUT command can only be used by a user who has authority to make a change and will immediately show a display (as opposed to the System/38 approach of using a function key).

The EDTOBJAUT display allows you to make changes using either the special values (for example, *CHANGE) or by changing the Xs. Assume the display is shown as follows:

User	Object Authority	----Object----			-----Data-----			
		Opr	Mgt	Exist	Read	Add	Upd	Dlt
JONES	*USE	X					X	
SMITH	*USE	X					X	
*PUBLIC	*CHANGE	X			X	X	X	X

If you want JONES excluded, you can change either the word *USE to *EXCLUDE or remove all of the Xs. You can also do both, but if you are inconsistent (for example, not removing all of the Xs), you receive a message. Assuming you changed the word to *EXCLUDE and pressed the Enter key, the display would now be shown without the Xs:

User	Object Authority	----Object----			-----Data-----			
		Opr	Mgt	Exist	Read	Add	Upd	Dlt
JONES	*EXCLUDE						X	
SMITH	*USE	X					X	
*PUBLIC	*CHANGE	X			X	X	X	X

If you want to remove JONES entirely (for example, make him part of *PUBLIC), you must insert blanks for the *EXCLUDE special value that appears in the *Object Authority* column. If you want to remove SMITH entirely (also make him part of *PUBLIC) you must insert blanks for both the special value *USE and the Xs.

If you want to set JONES to have read and update authorities (but not add or delete authorities), there is no special value to set for this combination. You can achieve this by doing either:

- Set the Xs the way you want them. The display is then shown with the special value USER DEF.
- Set the special value to *USE. When the display is shown again, it has Xs in the *Oper* and *Read* authority columns. Add the X to the *Upd* authority column. The display is shown with the special value USER DEF.

The OS/400 GRTOBJAUT command can set the *EXCLUDE authority for either the *PUBLIC or an individual user by granting *EXCLUDE. This revokes any existing individual authorities. For example, to exclude JONES from the PAYMST file you could specify:

```
GRTOBJAUT OBJ(LIBX/PAYMST) OBJTYPE(*FILE)
          USER(JONES) AUT(*EXCLUDE)
```

Normal authority: Most of the System/38 environment commands that set security (the CRT commands PUBAUT parameter, and GRTOBJAUT and RVKOBJAUT commands AUT parameter) have changed for the definition of *NORMAL. The value *NORMAL now specifies all of the data authorities (read, add, update, and delete) to the object. Some object types exist where all of the data authorities are not meaningful, but all of the Xs are shown by DSPOBJAUT.

For a message file object, this is different from System/38 if *NORMAL is specified. The add, update, and delete authorities were not granted on System/38. ADDMSGD requires the add

authority, CHGMSGD requires the update authority, and RMVMSGD requires the delete authority. All of these functions can be used on the AS/400 system using *NORMAL authority.

This is only a consideration if a message file is created on the AS/400 system (in either the System/38 environment or OS/400 program) or a GRT or RVK is used. Migration of existing objects keeps the authorities as they were on System/38.

The public authorization for the objects created by CRTJOBQ and CRTOUTQ remains the same as on System/38. However, *NORMAL applies to all data authorities on the GRT and RVK commands. The additional data authorities control the ability to use the CHG, CLR, HLD, and RLS commands for job queues and output queues.

The public authorization for the objects created by CRTUSRPRF and CRTSAVF remains as it was on System/38 (*NONE for the System/38 environment and *EXCLUDE for the OS/400 program). Details are provided in the *Security Concepts and Planning*.

List of passwords: The DSPUSRPWD command that produced a list of users and passwords on a single sign-on option is not supported. The AS/400 system has only a two-level sign-on which encrypts passwords so they cannot be meaningfully displayed. If users forget their password, the security officer should assign a new one.

New library support consideration: The new functions for current library and product library (see "Library" on page 2-16) create additional exposures to writing secure functions. If you have programs that are intended to be secure, you should have considered the library list implications as discussed in the System/38 *CPF Programmer's Guide*, SC21-7730-9 security chapter on Library List implications. The corresponding section has been updated for the *Security Concepts and Planning* on the AS/400 system.

Debugging: Debugging a program requires *CHANGE authority to a program rather than the *READ right as on System/38. See "Debug" on page 2-7.

Changes to IBM-supplied profiles: The QCE and QPSR profiles do not exist on the AS/400 system. Two new profiles exist named QSRV and QSRVBAS. See "Service" on page 2-44.

The new profile QTSTRQS (Test Request) is used when the 5250 test request function is specified. On System/38, the QCE profile was used.

The new profile QDFTOWN (Default Owner) is the owner for these typical cases:

- Restoring a new object when the owner does not exist on the system
- Finding an object with RCLSTG and the owner cannot be determined

The purpose of the separate profile (QDFTOWN) is to allow you to determine what objects have no owner.

The QUSER profile still exists, but cannot be used without entering a password on a level 20 or 30 system. The shipped password is QUSER. You may change the value or enter *NONE.

The IBM-shipped profiles do not have the same default passwords. The defaults now are the same as the profile name. For example, the QSECOFR default password is now QSECOFR instead of SECOFR.

Displaying and changing user profiles:

DSPUSRPRF only shows the profile parameters. No function key exists to allow changes. An OS/400 command (WRKUSRPRF) allows a simple method of changing existing profiles. The CHGUSRPRF command still exists.

Shipped authorization: The authorization shipped on IBM commands has changed from System/38. This is true for both AS/400 commands and the System/38 environment commands. Predominantly, this change makes more commands public (for example, many of the CRT commands were authorized to QPGMR on System/38 and are public on the AS/400 system).

If your end users are operating from user menus (not IBM menus) and cannot access a Command Entry display, you should see no significant differences. For those users who can access command entry, you need to review the authorizations described in the *Security Concepts and Planning* manual.

When the Migration Aid performs the restore authority (RSTAUT) function, the authorities associated with the IBM-supplied profiles are not granted.

System request function: If you have secured the system request function on System/38, a change is required. See "System Request" on page 2-55.

Logical file creation: See "Database" on page 2-5 for a change regarding the requirement to have object management authority to create a logical file.

Authorization list: The new authorization list function allows you to secure multiple objects using a single authorization list. The authorization list is maintained with commands to designate users and their authorities.

DST: The DST display is protected by three profiles. Each has a password that is set as part of the DST support. The DST profiles and passwords have no connection with the OS/400 program. A different function is used to sign on DST and to change the passwords. See "Service."

An exception has been made to the concept that DST and the OS/400 program are separate security functions. If you forget the QSECOFR password, you can reset the password to QSECOFR as a function of the DST master profile. The inverse is also true; if you forget the DST master profile password, the security officer can reset it with the OS/400 CHGDSTPWD command.

References: See "Cross-Reference" on page 2-5 for a change in the DSPPGMADP outfile.

The *Security Concepts and Planning* manual contains more information on security.

Service

Major service functions: The OS/400 program supports two major service functions:

- System Service Tools (SST)

SST allows access to service functions while the OS/400 program is operational. It has similar functions to the Concurrent Service

Monitor (CSM) on System/38 plus additional functions. You must have authority to perform the functions. Two profiles are shipped with the system (QSRV and QSRVBAS) to assist in performing the service functions and you may authorize other profiles.

The QSRV profile is intended for full servicing capabilities and allows the display/alter function for any information on the system. The QSRVBAS profile is intended for display of service information and prevents modifications to critical system functions.

Most of the functions of SST only need to be performed under IBM direction.

- Dedicated service tools (DST)

The DST support replaces the SM/1 diskette function on System/38 and adds other functions. Three passwords are associated with specific DST functions. The first two passwords allow functions which correspond to those provided by the QSRVBAS and QSRV profiles. The third password includes the QSRV type functions and also the capability to change the DST passwords. The passwords are set with DST and not with the OS/400 program.

DST allows you to perform low-level service-oriented functions. DST is normally accessed by performing an IPL with the keylock in the Manual position. The console device is used by DST. See "Initial Program Load (IPL)" on page 2-13 for the definition of the console device.

Most of the functions of DST only need to be performed under service direction.

However, the disk device configuration functions associated with checksums or user ASPs must be done by you with DST instead of OS/400 commands.

Unsupported functions: The System/38 commands DSPSTGCFG and CLCSTGCFG are not supported. The same functions can be accessed by either the DST or SST service functions.

DST is used to configure checksums or ASPs. The System/38 CHGSTGCFG command is not supported and the CFGSTG parameter is ignored on PWRDWNSYS.

The following service functions on System/38 no longer exist on the AS/400 system:

- CSNAP
- BSC diagnostic
- SLV update
- Vary power control
- MCR update
- Error logging control
- Diskette Repair Utility
- QSRV Log

References: See also the sections on:

- “Problem Determination” on page 2-26.
- “Programming Temporary Fix (PTF)” on page 2-28.
- “Problem Log” on page 2-27.
- “Problem Analysis Function” on page 2-26.
- “System Support” on page 2-56.

See also the change in “Security” on page 2-36 relative to the new service profiles and also the resetting of passwords.

Session Description: Created by the RJE utility. No changes. See “Remote Job Entry (RJE) 5714-RC1” on page 2-65.

Shipped Objects: The IBM objects that are shipped in QGPL have changed. See the discussion in Chapter 7.

The objects which you can change in QSYS (for example, print files) must be changed in the same manner that you changed them following a new release on System/38. A job stream or CL program should be used to change such things as the form size for the print files.

Sign-On

Security levels: When level 20 or 30 is used for the Security Level (see “Security” on page 2-36), a two-level sign-on is required. This means the user must enter both the user name and pass-

word. System/38 single-level sign-on (password only) is not supported. If you are migrating the System/38 user profiles from a single-level sign-on, the same passwords are in effect and they are encrypted.

Optional values: Optional values are shown on the Sign-On display for:

- Initial program
- Initial menu
- Current library

The user profile parameter LMTCPB (limit capability) controls whether the user can enter these values on the Sign-On display. The Migration Aid uses the System/38 user profiles as the default which results in a value of LMTCPB(*NO). This means the user signing onto the profile can change these values. The LMTCPB default also lets a user enter commands on a Command Entry display.

On System/38, only the initial program function was supported and there was no option on the Sign-On display to allow a change. Many end users were controlled by user-written menus that were started by an initial program and never allowed access to a Command Entry display. To achieve the same type of support as existed on System/38, you need to change the end user profiles to say LMTCPB(*YES).

The LMTCPB(*PARTIAL) function allows users to change only the INLMNU parameter on the Sign-On display and allows them to enter commands on a Command Entry display.

If the QCMD routing program is used (it is the default), the sequence of functions performed is:

1. The user profile ATNPGM is set.
2. The initial program is run.
3. If the initial program does not exist or completes without a sign-off, the initial menu is run.

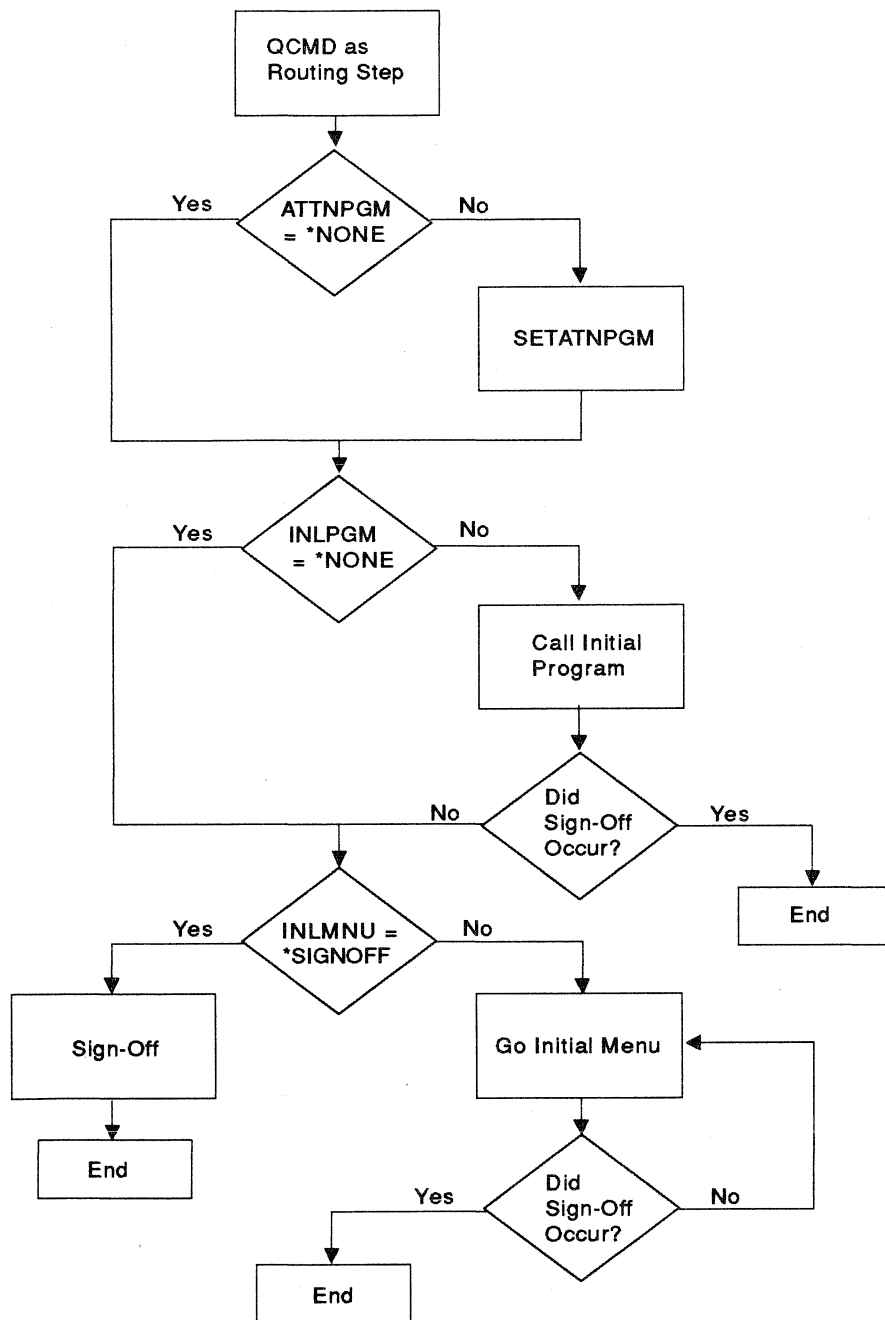

RV2W318-0

- If a sign-off occurs in the initial program, the initial menu is never run.
- The initial program must either not exist or do a return for the initial menu to be run.
- A special value is allowed for the initial menu which is *SIGNOFF. This means that a user is signed off if the initial program does a return. This entry is designed for those users who are controlled solely with an initial program. A message is sent to the operator if this occurs.

If your approach to security on System/38 was to control the user through a menu presented by an initial program, you may want to set the migrated profiles to INLMNU(*SIGNOFF).

User defined sign-on display: On System/38 the *CPF Programmer's Guide Work Management* chapter describes how to create your own Sign-On display. If you have done this, the display file must be changed to adhere to the new requirements.

You can create your own Sign-On display so that your users do not see the initial program, initial menu, or current library options. This forces the values in the user profile to be used regardless of the setting of LMTCPB in the user profile. The *Work Management Guide* contains more information.

Displaying the command entry function: If you want to see the Command Entry display immediately at sign-on, the QCMD routing entry requires you to specify the initial program as QCMD. This puts QCMD twice in the program stack.

With QCL as the routing entry, the System/38 environment Command Entry display is shown if there is no initial program.

Note: The functions of ATNPGM and INLMNU occur only if the routing entry is QCMD. The QCL routing entry only performs the function it did on System/38, which was to start the INLPGM function or show the Command Entry display if the initial program ended or did not exist. Therefore, with QCL as the routing entry, the initial menu function is ignored.

If you have your own routing entry program, you can receive a message indicating the values that were passed in from the Sign-On display and retrieve information from the user profile to determine the processing requirements. See the *Work Management Guide* discussion of the Sign-On display.

Inquiry message: The inquiry message that occurred when QCL was to be ended and was the first program in the program stack still exists. QCMD also supports the inquiry message, but the message only occurs if QCMD is the second program in the program stack.

SNADS

Migration: SNADS operates only in the OS/400 program. Most of the System/38 SNADS commands continue to operate unchanged in the System/38 environment, but you must configure the SNADS objects (they are not migrated by the Migration Aid). You should not attempt to save the files used by SNADS in the QUSRSYS library on System/38 because the format of the files differs on the AS/400 system.

See Chapter 7 for suggestions on migrating the SNADS configuration information.

The major change is the use of the remote location name instead of the device description name in the next system table. Because of this change, the table is now referred to as the distribution queue and certain parameters reflect the new terminology. Because device files are not used, the system names must uniquely identify the system, to which you intend to communicate.

Database: The distribution log associated with SNADS is a journal. Database file definitions are provided to use in conjunction with DSPJRN to convert the data so it may be processed by user applications.

The database file formats used for these definitions have changed to reflect changes in field names, attributes, and values. The files which have changed are:

SNADS Logging	QAZDCFLG
SNADS Logging	QAZDERLG
SNADS Logging	QAZDRTLK
SNADS Logging	QAZDJRNL

The *Distribution Services Network Guide* contains a description of these files.

Parameters: The Node ID (NDEID) parameter supported on several SNADS commands is ignored in the System/38 environment and dropped on the corresponding OS/400 commands. This specified the two part name in the next system table.

The DSPDSTLOG command ENTYP parameter allowed the value next system table (*NST). This has changed to distribution queue (*DSQ).

Source Attribute: See "Object Attributes and Source Types" on page 2-23.

Source Files: Other than the source type changes described in "Object Attributes and Source Types" on page 2-23, no changes have been made from System/38.

Spelling Aid Dictionary: See "Dictionary 5714-DCT" on page 2-62.

Spool

Operational displays: The operational displays have changed significantly. In general, more information is available for an individual spooled file such as the date and time the file was created. The program name that opened the file is also available if the program was created on the AS/400 system in either the System/38 environment or the OS/400 program (the conversion function performed by restore does not cause this). The program name appears in the *User Data* column. See "Spool" on page 4-14 for how to override this.

New support: New support allows a spooled file to be easily moved to the top of the queue. The OUTPTY parameter has been added to CHGSPLFA to allow this and can be conveniently entered on a display with a parameter line like DSPOUTQ.

New support exists to allow you to control the name of the spooled file. See "Spool" on page 4-14.

New support allows an entry in the user profile to easily specify that all spooled output should be directed to a specific printer. Several objects, parameters, and defaults are used to cause this. It is not completely necessary to understand the details of this approach. However, several conclusions can be drawn:

- To direct the spooled output of all users to a single system printer, use all the defaults.
- It is important that the QPRTDEV system value specify a real printer. This should be the default device you want the spooled files directed to. If the print device for a spooled file does not exist, the output is sent to the QPRINT output queue.
- All of a user's spooled output can be directed to a special printer by changing the PRTDEV parameter in the user profile.

- All of a user's spooled output can be directed to a specific output queue by specifying the user profile OUTQ parameter. The queue may currently be attached to a print writer, may eventually be attached or may never be attached. For example, the user may select those files to be printed by moving the spooled files to a queue that is attached to a print writer (for example, by use of the CHGSPLFA OUTQ parameter).
- A user can have a default function that occurs and yet have some files specified to go to a specific output queue. Specify the print file OUTQ or DEV parameters on the print file or the OVRPRTF command.
- Flexibility allows you to tailor for unique situations.

Migration: From a System/38 migration viewpoint the key things to consider are:

- If you take all the defaults on System/38, the output goes to the QPRINT output queue. If you take all the defaults on the AS/400 system, the output goes to the output queue associated with the device specified for the QPRTDEV system value. Be sure the QPRTDEV system value represents your default printer.
- The Migration Aid migrates the user profiles that specify OUTQ(*NONE) to be OUTQ(QGPL/QPRINT). Any System/38 migrated profiles use the same defaults as they did on System/38. You should consider specifying an output queue for new user profiles.
- If your applications use the OUTQ parameter to direct spooled output to different queues, the applications continue to operate in the same way. In the following discussion, it is important to remember that the OUTQ parameter overrides the PRTDEV parameter. If you specify an OUTQ, it is honored if the file is spooled.

Destination of printed output: The following describes the approach and the steps used in deciding where the spooled output is sent:

1. When a printer device is created, an output queue is implicitly created of the same name and is placed in library QUSRSYS. This is a new function on the OS/400 program. It is the intent of this approach that normal output to the print device would be spooled to the output queue associated with the device.

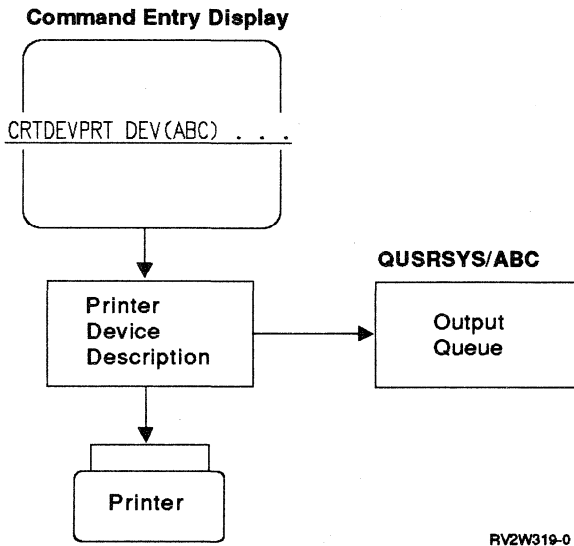

2. A new system value QPRTDEV is used as the default name for printing activity. The system value is shipped with a value of PRT01. (If you ordered a TSP system, the name is P1.) This is the name that is assigned to the first printer if automatic device configuration is requested. (See "Device Configuration" on page 2-7.) If you

choose not to use automatic configuration or want a different default printer, you must change this system value. It must contain the name of a valid printer on your system for the defaults to work correctly.

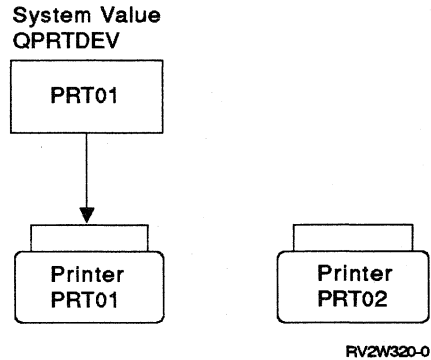

3. When a job starts, it always has both a job description and a user profile. (See the following illustration.)
 - A** The job description is copied into the job and provides the initial values for the job attributes. Some of the job description parameters have values that default to the user profile. The two that are important to this discussion (PRTDEV and OUTQ) both have a default value of *USRPRF.
 - B** If the defaults are used, the real values are accessed from the user profile. The user profile value for PRTDEV defaults to the QPRTDEV system value.
 - C** When job initialization is complete, the two attributes are filled.

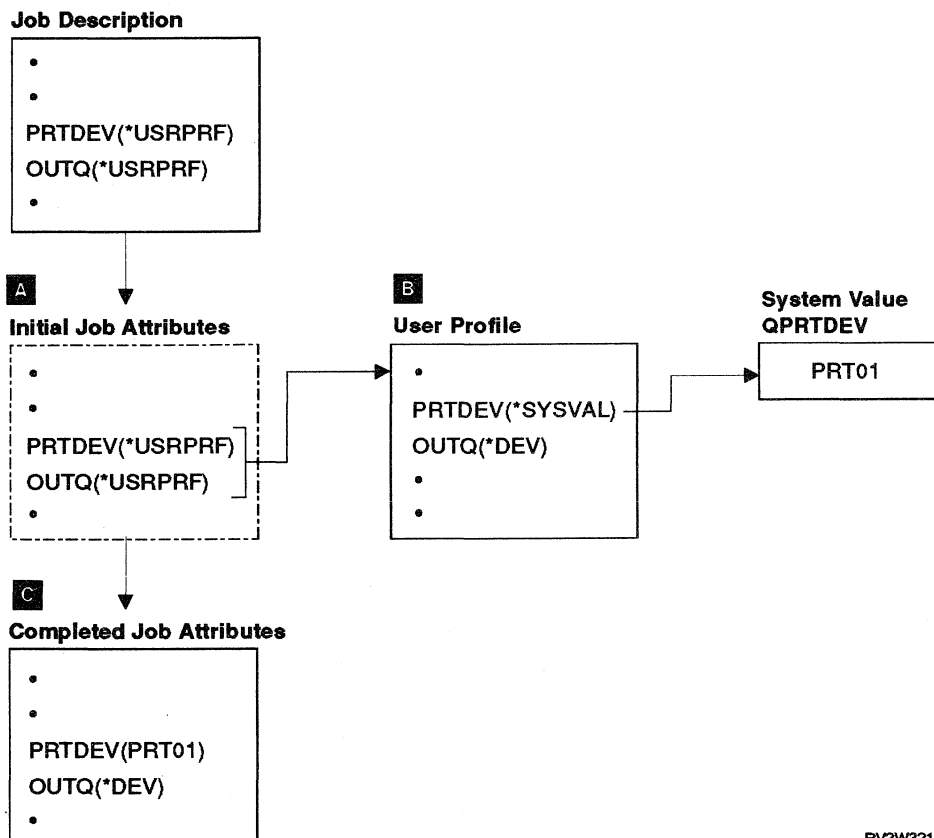

RV2W321-0

These attributes provide the base values for the job. The printer file also has the PRTDEV and OUTQ parameters that may specify to use these job attributes (described in step 5). The default is *JOB.

Note: The OUTQ parameter can specify *DEV. If the printer file is directed to use the job attributes, the output queue to be used is the queue associated with the PRTDEV parameter specified in the printer file. The PRTDEV attribute contains a name of a printer. The OUTQ parameter contains

either an output queue name or the value *DEV.

4. Once the job starts, the values in the job description, the user profile, or the system value are no longer used to determine the job attributes. Any changes are ignored for active jobs. The CHGJOB command can be used to change the PRTDEV or OUTQ job attributes while the job is active.
5. When a program opens a print file, the open routine goes through a series of steps.

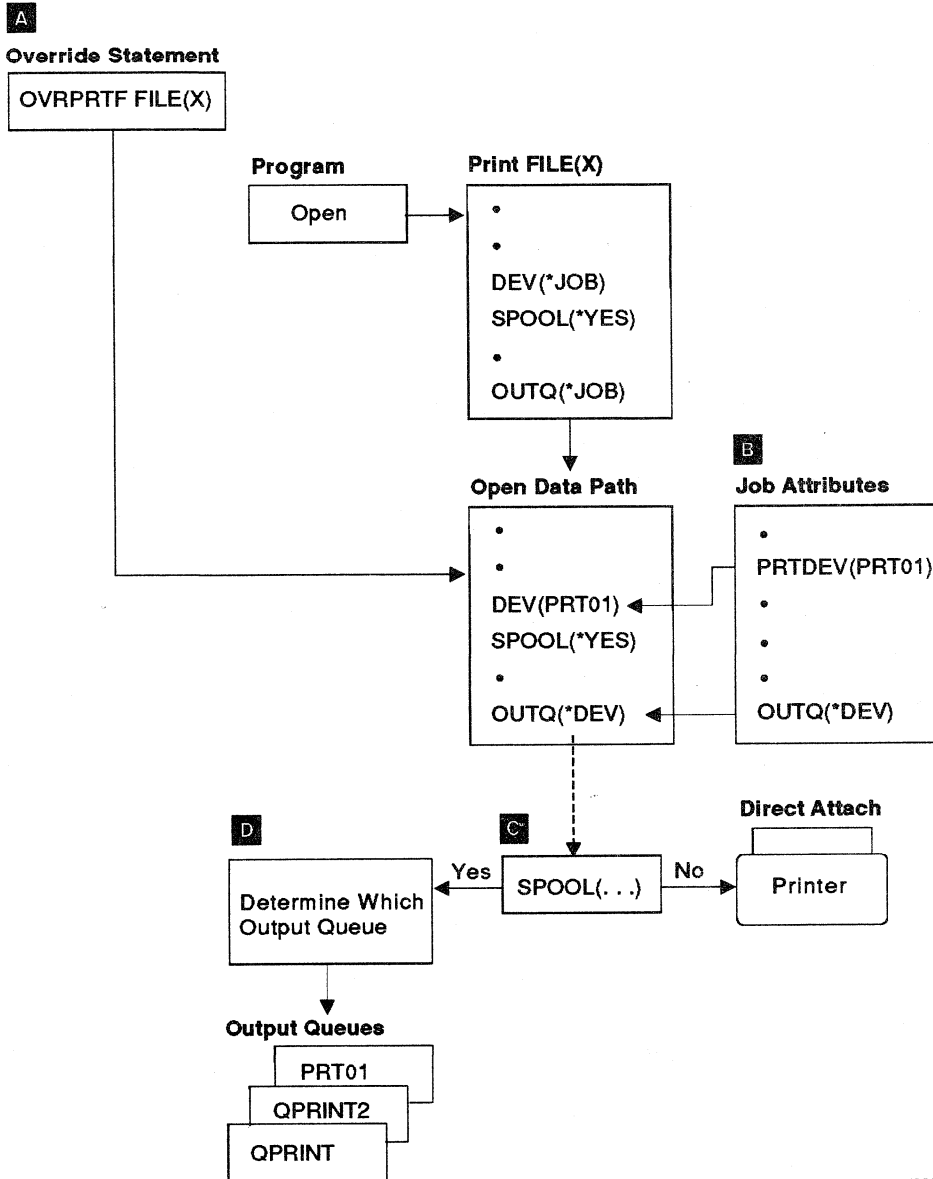

FV2W322-0

A If the OVRPRTF command is specified before your program opens the print file, the overrides are merged with the print file attributes to create the temporary object called an Open Data Path (ODP). Only one set of attributes exists after the merge. If no overrides are specified, the print file attributes are used. If the defaults were taken, the important values to this discussion are:

DEV = *JOB
 SPOOL = *YES
 OUTQ = *JOB

B The DEV parameter value is determined if the file is not spooled. The DEV parameter in the Open Data Path is evaluated as follows:

DEV = *JOB	Use the job attribute PRTDEV
DEV = *SYSVAL	Use the name in QPRTDEV system value
DEV = xxx	Use the xxx printer device

In the previous illustration, the Open Data Path DEV attribute of *JOB causes the job attribute of PRT01 to be used.

C The Open Data Path is checked to see if it should be directly attached to a printer. Attached directly means that you are not using spooling, but will specifically allocate a physical printer device. If SPOOL(*NO) is specified in the Open Data Path, direct attach printing is requested and step D would not occur.

D Determine the OUTQ to use. Assuming SPOOL(*YES) in the Open Data Path, the OUTQ parameter in the Open Data Path is evaluated:

OUTQ = *JOB Use the job attribute OUTQ
OUTQ = *DEV Use the DEV name determined in step B
OUTQ = xxx Use the xxx output queue

Note: If *DEV is specified (either in the Open Data Path or as the job attribute), spooling occurs as long as SPOOL(*YES) is specified. The output queue selected is the queue associated with the device. If the device does not exist, the output is sent to the QPRINT output queue. This refers back to step 1 which describes an implicitly associated output queue with every device.

While it appears that the keyword values are pointing at a device, they are really pointing at the output queue associated with the device.

If the file is spooled, the DEV parameter is not displayed for a spooled file. The CHGSPLFA command (in the OS/400 program) supports both the DEV and OUTQ parameters. If you specify a value for DEV, the spooled file is moved to the output queue associated with the device you specified.

Authority: The user-profile special authority *SPLCTL allows a user to access, change, and delete any spooled file on the system regardless of authority. This function allows the security officer and any other user with *SPLCTL to work with any spooled file on the system.

*READ authority to an output queue is now required to place a spooled file on that output queue. On System/38, *ADD authority was required.

Devices: Card devices are not supported, so card spooling is not supported.

Diskette spooling is limited to a single slot. The LOC keyword may be specified on System/38 environment spool commands (for example, STRDKTWTR), but is ignored.

File names: The spooled file names used by the commands that create objects from source will change. See "Languages" on page 2-65, "Data Description Specifications (DDS)" on page 2-6, and "Command Definition" on page 2-2.

WRKSPLF: The new WRKSPLF command allows various options to assist in displaying spooled files. For example, it can display all spooled files belonging to a specific user. This can be very helpful in problem determination.

System Service Tools (SST): See "Service" on page 2-44.

Subsystem Description

Work station allocation: One of the significant enhancements on the AS/400 system from System/38 is the dynamic work station allocation function. See "Work station allocation" on page 2-9.

Backup subsystem: A new subsystem description exists (QSYSSBSD in the QSYS library) which you cannot change. Its purpose is to give you a usable subsystem in case another user-created subsystem description fails or you have changed your working version to an extent that it is unusable. QSYSSBSD is also used during the IPL if the controlling subsystem specified in the system value QCTLSBSD is not found.

IBM-supplied subsystems: The subsystems QBASE, QBATCH, QCMN, QCTL, QINTER, and QSPL are in the QSYS library and can be changed. These subsystem descriptions are designed to meet different requirements. You may use the subsystems in QSYS without any changes, make changes, or create your own subsystems.

To create your own subsystems, you may use the CRTDUPOBJ command to create copies of these IBM-supplied subsystems in a user library.

Note: If you want the system to check your copies of the controlling subsystems for performance adjustment, the copies must be in the QGPL library. See "Performance adjustment option" for more information on performance adjustment.

There are two subsystem approaches:

- **Simple subsystem approach.** A single subsystem (QBASE) is used as the controlling subsystem and is also used for interactive, batch, and communications work. Spooled work is done in the QSPL subsystem. For QBASE, multiple storage pools exist and routing entries direct the work to the pools with different processing priorities. However, all the pool entries use *BASE so that all batch and interactive work is done in the same pool.

QBASE is the default controlling subsystem shipped in the QCTLSBSD system value.

An automatic start job exists using a special job description QSTRUPJD. See "Automatic job start" on page 2-54.

- **Multiple subsystem approach** using the following subsystems:

Controlling subsystem	QCTL
Interactive work	QINTER
Batch work	QBATCH
Spool work	QSPL
Communications work	QCMN

The multiple subsystem approach is similar to what was shipped as a default for System/38. However, the QCTL subsystem also supports an automatic start job using the same job description (QSTRUPJD) as in the QBASE subsystem.

To use the multiple subsystem approach, you must change the system value QCTLSBSD to QCTL QSYS.

Note: The QCTLSBSD system value is not migrated by the Migration Aid.

The storage pools set up are the same for both approaches. The shipped entries all use *BASE as the pool to run in. Note the later discussion

of IPL performance adjustment and how it may affect these pools.

For some System/38 users, the simple subsystem approach may be adequate. It is designed for simple approaches where the IBM defaults are adequate, the changes to the subsystem are infrequent, and the need to control independent types of work is infrequent.

The multiple subsystem approach allows you to start and end classes of work (for example, batch and interactive) in a more convenient manner by starting and ending subsystems.

The multiple subsystem approach is also much more convenient to work with if you have complex routing entries to deal with or a frequent need to change the subsystems. On the AS/400 system, as on System/38, some of the attributes of a subsystem cannot be changed while the subsystem is active.

For example, if you need to change an interactive routing entry, it is much easier to do it with the multiple subsystem approach. With the simple subsystem approach, you must change the QCTLSBSD system value to QSYSSBSD in QSYS, power down, do another IPL, change the QBASE subsystem, change the system value back to QBASE, power down, and do another IPL. With the multiple subsystem approach you need only end the QINTER subsystem, make the change, and then start QINTER again.

Both subsystem approaches contain the special entries needed to allow both the System/36 and System/38 environments to be operational.

Performance adjustment option: In conjunction with the two subsystem approaches, the system has a new function called **performance adjustment** which is controlled by the system value QPFRADJ. The default is to cause a performance adjustment at IPL. This function sets the storage pool sizes and activity levels based on the system model, main storage size, and the configuration-related descriptions that exist.

Note: This function only occurs when you do an IPL. It resets the values on each IPL when the system value is set. It is not a dynamic adjustment function that changes as your work load changes.

If an adjustment is requested by the QPFRADJ system value, the following occurs:

- The QMCHPOOL system value is set based on the size of your system and the configuration-related descriptions that exist (for example, how many communications line object types are in existence).
- The QSPL subsystem is changed for the storage pool size and activity level based on the number of printer device descriptions that exist.
- The system checks the controlling subsystem to see if QBASE or QCTL is specified. The system also checks whether the controlling subsystem is in the QSYS or QGPL library. If the controlling subsystems are not found in either library, a message is sent to QSYSOPR and IPL tuning completes.
- If the controlling subsystem is QBASE, the QBASE subsystem is changed to provide a unique storage pool value and activity level for the pool associated with interactive work. The QBASACTLVL system value is also set. The pool sizes and activity levels are set based on the size and model of your system.
- If the controlling subsystem is QCTL, the system performs the same function as for the QBASE subsystem except that the QINTER subsystem is changed for interactive work. The QBASACTLVL system value is also set.

Note: The assumption is that the typical system achieves the best performance results by separating the interactive and batch work in separate pools, not necessarily separate subsystems.

The intent of the performance adjustment is to provide a workable solution for many small system configurations. If you have a large system configuration or unique requirements, you should consider the same type of performance adjustments you did on System/38. Another alternative is to let the system perform the adjustment after you have created your configuration-related descriptions. Then set QPFRADJ off. This provides a base set of values from which you can begin making the changes.

Automatic job start: The purpose of the controlling subsystem having an automatic start job is to simplify what you need to do to automatically start certain functions at IPL. Refer to the *Work*

Management Guide for details. The highlights include:

- The QBASE and QCTL subsystems are shipped with an automatic start job entry defined. The automatic start job operates under the new QSTRUPJD job description. This uses the QPGMR user profile and causes an IBM program (QWDAJPGM) to be run.
- The IBM program (QWDAJPGM) checks the system value QSTRUPPGM and if it is not *NONE, transfers control to the program specified in the system value. The system value QSTRUPPGM supports the following:
 - QSTRUP: This is the name of the IBM-supplied program. This is the default. It performs the following:
 - All subsystems in either subsystem approach (as defined previously) are started.
 - All spool writers are started if the system value QSTRPRTWR is set to yes. An IPL Options display sets the system value on each IPL. The default is yes and is used if the operator does not make an entry or an unattended IPL occurs.
 - Qualified program name: Your own start up program should be run.
 - *NONE: No startup program should run.

Routing entry: The routing entries shipped for the IBM-supplied QBATCH and QINTER subsystems each contain entries for QCMD and QCMD38. The QCMD entry calls QSYS/QCMD. The QCMD38 entry calls QSYS/QCL. The SBMJOB RTGDTA default differs between the System/38 environment and the OS/400 program as follows:

System	RTGDTA Default
System/38 Environment	QCMD38
OS/400 Program	QCMD

If you operate interactively from the OS/400 program, you should use the new CMD parameter to enter the command you want to run in batch. The proper syntax is passed to the QCMD processing program.

If you use the RQSDTA parameter in either the System/38 environment or the OS/400 program, you must enter the proper syntax to match the

RTGDTA value. For example, if you are in the OS/400 program and specify:

```
SBMJOB RQSDTA ('CALL PGMA.LIBRARY1')
```

the command fails when processed by QCMD. You need to either use OS/400 syntax (LIBRARY1/PGMA) or specify RTGDTA(QCMD38).

Job description: One of the major changes from System/38 is the default association of a job description with a user profile. The AS/400 system is designed to allow you to use a general purpose job description (QDFTJOB in QGPL) or to assign a specific job description to user profiles. In conjunction with this support, the workstation entries (for example, ADDWSE) now use the job description of the user who signs on as the default rather than the job description of the same name as the subsystem. The CRTUSRPRF default for the JOB parameter has changed to QDFTJOB.

The result of these changes means that the job description used at sign-on is now *user oriented* instead of being *subsystem oriented*. You may want to take advantage of this support for many, if not all, applications.

Monitor job: On System/38, each subsystem has a monitor job which runs in the first storage pool assigned to each subsystem (this is normally the QBASE pool). The activity caused by the monitor jobs had to be accounted for when determining the activity level for the pool.

On the AS/400 system, the subsystem monitors continue to operate in the first pool assigned to each subsystem, but the activity is now handled internally. Consequently, you do not have to consider the monitor jobs when determining an activity level for the subsystem pools. The activity still counts toward the system wide activity level (QMAXACTLVL system value).

Pool size: The minimum pool size has been changed from 16K to 32K.

Other changes: Other changes in the definition of the subsystems concern the shipped defaults on System/38 and those shipped on the AS/400 system. If you have used the System/38 defaults, little must be done other than to determine which subsystem approach you want by specifying the QCTLSBSD system value.

If you have changed the System/38 supplied subsystems, you need to review the changes and may need to make changes to the OS/400 versions.

See the discussion on subsystem descriptions in Chapter 7.

System Reply List: The System Reply List is not migrated from System/38 by the Migration Aid. You must perform a manual conversion.

Operationally, there are no changes from System/38. PL/I has been added. See also the discussion on "System reply list" on page 7-4.

System Request

Menu changes: The System Request menu has the following changes:

- Option 3 (Display current job) is changed so that it uses the OS/400 DSPJOB command. The user is not allowed to make any changes such as CHGJOB or deleting objects from the display library option.
- Wording changes have occurred. The menu now checks for whether a pass-through job or secondary job is active and changes the wording of the options to better describe the choices. The pass-through options are only displayed if pass-through is active.
- The prompter is always used for the DSPMSG, SNDMSG, or SIGNOFF options when entered from the menu.
- The system request line can still be used to enter the command parameters for any option.
- A new option is shown to display the QSYSOPR message queue.

Security changes: On System/38, the System Request menu was created as a display file. On the AS/400 system, it is a panel group (*PNLGRP) object type. Consequently, the technique of preventing the use of the system request function by revoking the authority to the QMNSYSRQ file can no longer be used. To prevent the public from accessing the System Request menu, issue the following command (the grant of *EXCLUDE will revoke any individual rights).

GRTOBJAUT OBJ(QSYS/QGMNSYSR)
 OBJTYPE(*PNLGRP)
 USER(*PUBLIC)
 AUT(*EXCLUDE)

You can then grant the use of the System Request menu by specifying AUT(*USE) to the appropriate users.

System Support: To fully use most of the new system support functions, you must have a communications line and the system must be operational. (question-and-answer local does not need communications.) System support has several functions:

Service: Both hardware and software service functions are supported. The software aspects include reporting problems and receiving program temporary fixes (PTFs) electronically.

Marketing information: This includes access to IBMLink. (available in U.S.A. only) or IBMDIAL (available in most European countries) for information to such things as announcements, education schedules, and file exchanges.

Question-and-Answer Database (Q & A): This includes both an IBM-supplied local and remote Q & A database as well as the capability to create your own Q & A. You may also access other remote Q & A databases. See *Q & A Database Coordinator's Guide*.

System Values

New values: Several new system values are associated with various functions. You need to review the new system values to determine how the values should be specified. Only the OS/400 commands can access the new system values (they cannot be accessed in the System/38 environment). (See the *Work Management Guide* for details about all system values.) Some of the new system values are:

Name	Description
QAUTOCFG	For specifying automatic device configuration. See "Device Configuration" on page 2-7.

QCONSOLE	Name of console device. The value cannot be changed. See "Initial Program Load (IPL)" on page 2-13.
QPRTDEV	Default print device name. See "Spool" on page 2-48.
QSTRUPPGM	Startup program name for IPL. See "Subsystem Description" on page 2-52.
QIPLDATTIM	When to automatically IPL the system.
QRMTIPL	For specifying a remote IPL.
QIPLTYPE	IPL type to perform (attended or unattended). See "Initial Program Load (IPL)" on page 2-13.
QIPLSTS	Type of IPL that was performed (replaces QAUTOIMPL).
QPWRRSTIPL	For specifying automatic IPL after power is restored. See "Uninterruptible Power Supply" on page 2-59.
QSTRPRTWTR	Should print writers be started at IPL. See "Initial Program Load (IPL)" on page 2-13.
QSECURITY	Security level (10, 20, or 30) of the system. See "Security" on page 2-36.
QKBDTYPE	Keyboard language selection.
QSPCENV	Default for special environment user profiles. See "Security" on page 2-36.
QDEVNAMING	Device naming convention for automatic configuration.
QPFRADJ	For specifying performance adjustments at IPL. See "Subsystem Description" on page 2-52.
QPWDEXPITV	Controls the number of days for which a password is valid.
QDSPSGNINF	Controls the display of sign-on information.
QMODEL	Allows users to determine on which model of the AS/400 system they are running.

Changed values: The following system values have been changed:

Name	Description
QSYSLIBL	QSYSLIBL is shipped with the following libraries: <ul style="list-style-type: none"> QSYS QUSRSYS QHLPYSYS
QMAXSIGN	Changed from DEC(5 0) to CHAR(6). The default value is now 15. It is now used for both sign-on attempts. <ul style="list-style-type: none"> • Sign-on for a work station (System/38 QMAXSIGN definition) • Sign-on for attended IPL (System/38 QSCPFSIGN definition)
QAUTOIMPL	This returns additional values (for example, IPL at time of day) to reflect the new types of IPL. QAUTOIMPL may only be specified in the System/38 environment. The new name in the OS/400 program is QIPLSTS. The new name is shown on the DSPSYSVAL display.
QCTLSBSD	The default value is now QBASE. See "Subsystem Description" on page 2-52.
QSCPFCONS	The default value is now 1.
QBASPOOL	Expanded to a zoned field of (10 0). The new default value is 500.
QMCHPOOL	Expanded to a zoned field of (10 0). The new default value is 1500.
QUPMSGQ	See "Uninterruptible Power Supply" on page 2-59.
QUPSDLYTIM	See "Uninterruptible Power Supply" on page 2-59.

Unsupported values: The following system values are no longer supported:

Name	Description
QCSNAP	The function is no longer supported. Some of the same function can be achieved using the device configuration THRESHOLD parameter.
QBADPGFRM	The function is no longer needed on the AS/400 system.
QSIGNLVL	A two-level sign-on is supported with security levels 20 and 30.
QSRVONLY	The function is no longer needed on the AS/400 system.
QCHGLOGSIZ	The QCHG log function is no longer supported.
QSRVLOGSIZ	The QSRV log function is no longer supported.
QSYSOPRDEV	The function is no longer supported on the AS/400 system.
QAUXSTGTH	The function is now supported using SST. The method of specifying the value has changed so you now express a percentage of used storage. The default is 90%.
QSCPFSIGN	This function is included in the QMAXSIGN system value.

Migration: In addition to the System/38 system values that are not supported on the AS/400 system, some system values are not migrated by the Migration Aid because they are read-only values:

QABNORMSW	Previous termination of CPF indicator.
QAUTOIMPL	Start CPF IMPL indicator.
QIGC	Indicates whether DBCS is installed.
QSRLNBR	System serial number.

The following date and time system values are not migrated by the Migration Aid. QDATE and QTIME values should be set on the AS/400 system.

QDATE
 QYEAR
 QMONTH
 QDAY
 QTIME
 QHOUR
 QMIN
 QSECOND

The following system values are not migrated:

Name	Description
QBASPOOL	Consider a new value based on the size of your system or use the performance adjustment option. See "Subsystem Description" on page 2-52.
QCTLSBSD	Use the new IBM-supplied version until you have successfully migrated.
QMAXSIGN	The function and type of attribute have changed. See the discussion on "Changed values" on page 2-57.
QMCHPOOL	The AS/400 system requires a larger value. See the <i>Work Management Guide</i> or use the performance adjustment option.

QSYSLIBL	The AS/400 system is shipped with three libraries listed in this system value. If you have modified this system value on System/38, make similar modifications to the AS/400 list.
QUPSMGQ	The definition has changed. See "Uninterruptible Power Supply" on page 2-59.
QUPSDLYTIM	The definition has changed. See "Uninterruptible Power Supply" on page 2-59.

Table: Tables are used for several functions on System/38 including the translation table used with system-attached printers. Only workstation printers are supported on the AS/400 system and therefore the TRNTBL parameter on print files is removed on the OS/400 commands.

No changes have been made to the table source entries or the commands.

Tape

Supported devices: Some of the tape devices supported are shown in the following table. The approximate capacities and rates shown are for save and restore operations. For data interchange, capacities and rates may vary. For a complete list, see the *Backup and Recovery Guide*.

Tape Device	Media Width in Inches	Type	AS/400 Models Supported On	Maximum Megabytes Per Hour	Rewind Time in Minutes	Maximum Media Capacity (MB)
6346	1/4	Streaming	9404	320	3.0	120
9346	1/4	Streaming	9404 and 9406	320	3.0	120
9347	1/2	Streaming	9404 and 9406	550	2.7	44
2440	1/2	Start/Stop	9406	1500	2.4	167
3422	1/2	Start/Stop	9406	2230	1.1	167
3430	1/2	Start/Stop	9406	950	3.0	167

The streaming devices can only reach the maximum speed if they can be kept streaming. If the device becomes ready to read or write and the system is not ready to read or write, a **backhitch** occurs. A backhitch requires that the tape come to a stop and then go back to the point where it is ready to read or write again. If several backhitches occur, the speed is reduced considerably.

Streaming devices should not be used for an excessive amount of data interchange (for example, reading or writing by CPYF). If data interchange is used, you should use large blocks to reduce the exposure of backhitching.

The 6346 and 9346 Tape Units (1/4 inch) cannot be read by the other supported devices. The 9347 and 2440 Tape Units can be used to read and write to each other, but only if written at the common density of 1600 bpi.

The 9347 Tape Unit operates at either 1600 or 3200 bpi.

The 2440, 3422, 3430, and 9348 Tape Units operate at either 1600 or 6250 bpi.

The 6346 and 9346 Tape Units must set the tension of the tape before they can start reading or writing. Depending on where the tape is positioned when the cartridge was removed, the time to set the tension is from 1-1/2 to 3 minutes. As with all tape processing, if you plan to write multiple files to the same tape (for example, multiple save commands), you should specify ENDOPT(*LEAVE). Because of the tension requirement, you should only specify ENDOPT(*REWIND) on the 6346 or 9346 when you intend to remove the cartridge.

The 6346 and the 9346 Tape Units do not support read backwards. Some high-level languages (for example, COBOL) have language statements for read backwards.

The 3422 and 3430 tape drives support hardware data compression (HDC).

System-supplied tape files: The default value of the RCDLEN parameter has changed from 80 to *CALC for the system-supplied tape files QSYSTAP/SYS, QTAPE/QGPL, and QTASRC/QGPL.

DSPTAP output: The DSPTAP format differs so only one file at a time is presented if used interactively. Once you display a file using DATA(*SAVRST), you cannot go back to a previous file unless you repeat the command.

Tape device naming: The QDEVNAMING system value controls the name of the default tape device. It is either T1 or TAP01, not QTAPE or QTAPE1 as it was on System/38. If your system is installed with the automatic configuration option, the device description already exists.

If you prefer to use a name like QTAPE and you are using automatic device configuration:

- Create the description QTAPE.
- Change the system created device description to ONLINE(*NO). This will prevent varying on the device (it must exist if you are using automatic configuration).

Test: See "Debug" on page 2-7.

Uninterruptible Power Supply: System/38 and the AS/400 system support two types of uninterruptible power supply functions called **basic** and **full**.

The full support requires that the processing unit and all disk devices are supplied electrical power by the uninterruptible power supply. 9404 Models B10 and B20 also support an optional Battery Power Unit. The system values that control the support have been changed and additional support exists. The three system values are:

QUPSMMSGQ	Message queue for messages
QUPSDLYTIM	Uninterruptible power supply delay time
QPWRRSTIPL	IPL if power is restored (new)

The two system values that existed on System/38 are not migrated by the Migration Aid.

The basic support is similar to System/38 basic support, but does not perform the full microcode completion function after an abnormal IPL caused by a power loss. The basic support supplies power only to the processing unit, Unit 1 (load source disk), and the storage controllers.

The QUPSDLYTIM system value definition has changed. It allows the system to wait for a designated period of time when utility power is lost. If the QUPSMMSGQ value does not identify a user message queue, the system powers down when the delay time ends. This should allow many users to use the uninterruptible power supply without requiring a user-written power-handling program. QUPSDLYTIM is changed from a 6-byte character value to a 20-byte value on the RTV command. The first 10 bytes are the value you specify. The second 10 bytes allow for the system to respond with an actual value when *CALC or *BASIC is specified.

The *Backup and Recovery Guide* contains more information.

User Profile: See "Security" on page 2-36.

Work Management

Default changes: The default for RTGDTA on SBMJOB and JOB on the System/38 environment commands is changed from *JOB to QCMD38. This allows the job to be processed by the correct routing entry in the IBM-supplied subsystems. This change may cause the following differences:

- If you have your own subsystems or have changed the IBM subsystems, you may need to change your routing entry to QCMD38 instead of QCMD3.
- If you were making use of unique RTGDTA values in job descriptions, you need to change the JOB or SBMJOB JOB parameters to specify *JOB (otherwise, the default of QCMD38 will occur). You will need to consider which program is used in the routing step for your unique RTGDTA.

Significant changes in the OS/400 program have been made regarding the SBMJOB command. See "Work Management" on page 4-15.

User message queue: A user message queue is now associated with the job and is transferred for any group job. See "Message Handling" on page 2-19.

Date format and separator character: New job attributes, DATFMT and DATSEP, describe the date format and the date separator character.

These default to the corresponding system values. Assuming the defaults are used in the job description and not changed during the job, the results are the same as on System/38.

WRKUSRJOB commands: A new command WRKUSRJOB allows you to work with all of the jobs for a given user or all users. It provides a simpler form for the system operator. You may want to use it for normal handling of work instead of DSPACTJOB. DSPACTJOB is still useful for investigating performance questions.

References: Specific work management topics are covered elsewhere in this manual. See the sections on:

- "Sign-On" on page 2-45
- "Subsystem Description" on page 2-52
- "Job Queue" on page 2-15
- "Job Description" on page 2-15
- "Initial Program Load (IPL)" on page 2-13
- "Job streams" on page 2-16

IBM-supplied nonchangeable objects: IBM ships the following objects that can be used if your subsystem objects become damaged or inoperable:

Description	Object	Library
Controlling subsystem	QSYSSBSD	QSYS
Class for routing entry in subsystem QSYSSBSD	QSYSCLS	QSYS
JOB for use with the ADDWSE command for the subsystem QSYSSBSD	QSYSJOB	QSYS
Job queue	QSYSSBSD	QSYS

For example, if your controlling subsystem description becomes inoperable, you could specify QSYSSBSD at the IPL Options display and IPL the system.

Work Station

Additional input fields: Additional input fields are supported for all local devices. The limit of 128 on System/38 has been raised to 256. See the *Data Management Guide* for reductions caused by certain DDS keywords. The 5294 Display Station or Work Station supports 254 fields. The 5251 M12 remote Work Station Controller continues to support 126.

Work station device naming: The QDEVNAMING system value controls the name of the default work station device. The special value *DEVADR from this system value causes the system to derive a device name from the resource name for a device description that is being created.

New local work station controller function: The local work station controller uses a different approach for sending data to the display. Depending on the type of display requested, a faster response may appear. For example, if the display is being completely rewritten, a burst mode is used to display the screen.

References: See "Data Description Specifications (DDS)" on page 2-6.

See "Return Codes" on page 2-35.

X.25: The status information commands (DSPCHLSTS and DSPLNKSTS) are not supported on the AS/400 system. X.25 statistics data is now gathered by entering the STRPFRMON command to begin collection of data, and the ENDPFRMON command to end collection of data (refer to the online help information for each command). The X.25 data is collected along with system data and other communications data by specifying *ALL for the DATA parameter on the STRPFRMON command. You can access this data in a database (see the *Work Management Guide*), or you can access this data with the IBM Performance Tools. For more information on the Performance Tools program, refer to the *Performance Tools/400 Guide*.

You can display status of your X.25 configuration using the WRKCFGSTS command. To display packet size and window size, use the WRKCFGSTS or DSPCTLD command to display the X.25 Controller Description. DFTPKTSIZE is the X.25 packet size and DFTWDWSIZE is the default window size. If the X.25 Controller Description is varied on or active, the negotiated packet and window sizes are also displayed as NEGOTIATED PACKET SIZE and NEGOTIATED WINDOW SIZE. Note that these negotiated

values are for switched virtual circuits and only available after a call has successfully completed.

Utilities and Other Licensed Programs

The System/38 licensed program numbers are used so you can cross-reference to the function.

Advanced Printer Function (APF)

5714-UT2: APF is no longer a separate licensed program, but is part of the Application Development Tools on the AS/400 system (5738-PW1). No changes exist in the function. The APF function continues to operate only to the 5224 Printer and 5225 Printer.

Business Graphics Utility (BGU)

5714-GP1: BGU is a separate licensed program. No changes exist in the function except that the chart heading is now part of the chart format and not in the chart data. New support has been added.

Cryptographic Facility (CRP) 5714-CR1

and the Cryptography RPQ: If you need to migrate the cross-domain key table (QACRKTBL) from System/38, you need to install a master key on the AS/400 system that is equivalent. This must be done before restoring the key table.

The DSPCRPHLP command is not supported on the AS/400 system. Help information is available from the operational displays.

Distributed Data Management (DDM)

5714-DD1: The separate licensed program on System/38 is now part of the OS/400 program.

Grouping: The *grouping* function for database query operations has changed internally. Consequently, both source and target systems must be of the same type (both the AS/400 systems or both System/38s). The following functions may use *group by*:

- OPNQRYF
- Any PC Support/400 file transfer download function

Request to Download

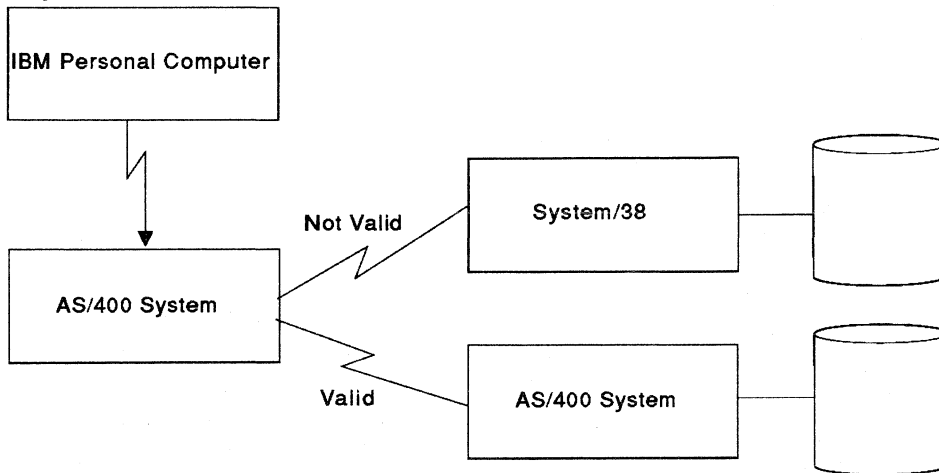

FV2W323-0

Similarly, if the personal computer is attached to a System/38, the request to download using DDM is only valid to a System/38 (it is invalid to an AS/400 system).

CRT commands: The CRTPF and CRTLF commands can now be used to create files on a remote system. The PFILE and JFILE DDS keywords must describe a file which is located on the same system as the file being created.

Changes: Changes to the DDM file definition may be required on the source system if the target System/38 system is replaced with an AS/400 system. See "Interchanging Using DDM" on page 5-2.

A significant change has been made in the OS/400 program for creating DDM files. See "Distributed Data Management (DDM)" on page 4-6.

Dictionary 5714-DCT: The IBM-supplied System/38 language dictionaries cannot be migrated to the AS/400 system. New dictionaries are available. Information on dictionary commands is available in the *CL Reference* manual.

User created dictionaries will be migrated and can be used by the Office Text editor.

The Dictionary product includes all languages (for example, French, English, and German).

You can choose to restore only specific dictionaries or to delete those you do not need.

IDU - CGU (Character Generator Utility)

5714-UT1: CGU is no longer a licensed program, but is part of the Application Development Tools on the AS/400 system (5738-PW1).

18-by-18 ideographic tables are not supported.

IDU - DFU (Data File Utility) 5714-UT1:

OS/400 DFU exists and is part of the Application Development Tools.

The System/38 DFU product is only supported in the System/38 environment. The System/38 environment product is found in the *DFU/38 User's Guide and Reference*.

There are no changes from the System/38 DFU to the System/38 environment DFU.

Library qualifying commands: To use a System/38 DFU command from an OS/400 command entry function, you must qualify the command with the QSYS38 library. For example, no option exists on the Programmer Menu to access System/38 DFU. You must enter the following type of command in OS/400 syntax.

```
QSYS38/DSNDFUAPP .....
```

To use a DFU application from an AS/400 program, you must also qualify the command such as:

```
QSYS38/CHGDTA .....
```

The CHGDTA and DSPDTA commands are somewhat unique in that they exist in both the System/38 environment and the OS/400 program, but the function differs. If you enter the CHGDTA or DSPDTA commands in the OS/400 program expecting the System/38 environment DFU, the command attempts to use an AS/400 DFU for the name you specified.

If you enter the DFU commands on a System/38 environment Command Entry display or in a CLP38 type program, you do not have to use a library qualifier.

IDU - Query 5714-UT1: OS/400 Query exists as a separate licensed program.

The System/38 Query product is only supported in the System/38 environment. The System/38 environment product is found in the *Query/38 User's Guide and Reference*.

No changes have been made from the System/38 Query to the System/38 environment Query.

Library qualifying commands: To use a System/38 Query command from an OS/400 command entry function, you must qualify the command with the QSYS38 library. For example, no option exists on the Programmer Menu to access System/38 Query. You must enter the following type of command in OS/400 syntax:

```
QSYS38/DSNQRYPAPP      .....
```

To use a Query from an OS/400 program, you must also qualify the command such as:

```
QSYS38/QRYDTA          .....
```

If you enter the Query commands on a System/38 environment Command Entry display or in a CLP38 type program, you do not have to use a library qualifier.

IDU - SDA (Screen Design Aid)

5714-UT1: SDA is part of the Application Development Tools on the AS/400 system (5738-PW1). The System/38 environment commands use a System/38-compatible form of the new AS/400 support.

Different source types are supported. See "Object Attributes and Source Types" on page 2-23.

IDU - SEU (Source Entry Utility)

5714-UT1: SEU is part of the Application Development Tools on the AS/400 system (5738-PW1). The System/38 environment commands use the new AS/400 support.

System/38 attributes are accepted. See "Object Attributes and Source Types" on page 2-23.

Enhancements: The find and change functions have been changed to be more compatible with the Systems Application Architecture function. The Member List Function and Services displays have been enhanced. More line commands have been added including tab columns and copy repeat. Full language prompts and user prompts are also available.

Intelligent Work Station Support 5714-PC1

Devices: The IBM Personal Computer/Display Station Emulation Card (part 6851206) is not supported by PC Support/400. All other IBM 5250 adapter cards are supported.

The *PC Support/400 DOS Installation and Administration Guide* contains information on other ways personal computers may be attached to the AS/400 system.

A PC device used with PC Support/400 cannot be used for those functions associated with an IPL. See "Initial Program Load (IPL)" on page 2-13.

Environment: The PC Support/400 utility operates in the OS/400 program. You must convert to OS/400 commands. For example, if you were using the CPYFRMVDSK command, you must convert to the CPYFRMPCD command. See Appendix A for the command changes.

Functions: The function provided by the EXITPGM parameter on BGNIWSSRV is replaced by the new network attribute PCSACC.

The transfer function has minor changes to the API on the personal computer. For example, a register pair is used on an open request to address the system name that files are transferred to or from. The *PC Support/400 Technical Reference for DOS and OS/2* contains more information.

There are differences with the support installed on the PC device. For example:

- The 5250 emulation application programming interface (API) cannot be used. Instead the Work Station Feature API, which has similar support, must be used.
- The PC Support router must be started in a different sequence and by the AS/400 STARTRTR command instead of the BEGINRTR command used on System/38.

The *PC Support/400 DOS Installation and Administration Guide* describes the differences for the PC user.

DOS requirements: The PC user must be using DOS level 3.3 or a later release.

Virtual disks: The Migration Aid converts virtual disks to folders on the AS/400 system.

If you do not use the Migration Aid, you can migrate the virtual disks as database files and use the CVTTOFLR command. This command is part of the PC Support/400 Utility.

There is no support for virtual diskettes. These were created by the File Support Utility PRPQ which was used prior to the System/38 PC Support Utility. Virtual diskettes must be copied to PC diskettes or converted to System/38 virtual disks using the PC Support/38 Utility before migrating to the AS/400 system.

Performance Tools PRPQ 5799-BJK: The System/38 Performance Tools PRPQ includes a variety of functions. Many of the data collection functions have become part of the OS/400 program and are supported by OS/400 commands. See the *Work Management Guide* and the *Performance Tools/400 Guide* for more information.

Commands and functions: The PRPQ no longer exists. The functions are incorporated in the new Advanced Performance Tools Licensed Program (5738-PT1). The files, displays, and commands are different and in some cases the approach is different. The System/38 commands do not operate in either the System/38 environment or the OS/400 program.

Several of the command names and functions have changed from the System/38 PRPQ. In

general, the level of the function is similar, but some function is now included in the OS/400 program. For example, the display of disk statistics that was in the DSPPF command is now supported by the WRKSYSSTS command.

No graphing of output is available.

A new capacity planning function is part of the Performance Tools licensed program. See the command MDLSYS. This includes expert system function to assist in capacity planning.

Data: Because the data is machine dependent, data captured on System/38 cannot be processed by the OS/400 commands.

The database formats that were used by the PRPQ have been changed. Programs that use those formats must be reworked.

Personal Services/38 5714-WP3: The *Using OfficeVision/400** describes the differences.

Reformat Utility 5714-CV2: The separate licensed program on System/38 has been incorporated into the OS/400 program.

Changes: The printer file name used for the printed output is the name of the source member instead of QSYSPRT.

Card files are no longer supported.

As on System/38, no syntax check is supplied for Reformat Utility specifications in SEU. The source type is TXT.

Enhancements: The following enhancements have been made, but existing System/38 specifications should operate in the same way.

- SORTR/FILE in the header specification is now in positions 7 through 12 instead of 7 through 10.
- Summary sort (SORTRS) and sorting records with identical control fields (SORTRE) are now supported.
- Alternate collating sequence for specific keys is supported.
- Two hundred fifty six bytes are allowed for the key instead of 248, but performance is degraded occurs if the length exceeds 248.

- Comment (*) is allowed in column 7 of the record specification.
- Factor 2 keyword in the record specification is supported.

Remote Job Entry (RJE) 5714-RC1: RJE is no longer a licensed program, but is part of the Communications Utilities on the AS/400 system (5738-CM1).

The CRTRJECFG function has been changed to account for the changes in device configuration. Two new commands (CRTRJEBSCF and CRTRJECMNF) exist and must be used to establish BSC or LU-1 RJE.

Text Management 5714-WP2: System/38 Text Management is now part of System/38 Utilities (5738-DB1). The documents created using these functions can be migrated to OfficeVision/400 documents with some changes in the document and the way in which you work with the file. On System/38, the type of printer was specified (such as *5219). On the AS/400 system, the actual device name is given (such as P2). For more information on the differences between System/38 Text Management and Office, see the *Using OfficeVision/400* Word Processing*. For more information on migrating documents to Office, see the *System/38 to AS/400 Migration Aid User's Guide and Reference*.

Text Management/38 on the AS/400 system allows users to create, store, retrieve, revise, check document spelling, provide synonyms and automatic hyphenation, and print documents. The user may access the AS/400 database interactively from the Text Management/38 program at edit time or at print time to include database information in a text document. In addition, forms may be created and filled in on the display or stored in the system for later use.

Text Management/38 on the AS/400 system supplies most of the editing functions supplied with System/38 Personal Services/38, 5714-WP3. Exceptions are listed below:

- Office functions, such as sending a document or filing a document in the document library, are not supported.
- 6670 and Displaywriter printer functions are not supported.

The support is similar to that which exists in the Personal Services/38 Editor as of Release 8 with the following significant exceptions:

- There is no access to OfficeVision/400 functions.
- No support exists for the 6670 or Displaywriter printers.

The *Text Management/38 User's Guide and Reference* contains more information.

Languages

For some languages, the name of the spooled file used for the compilation printed output will be the source member name specified on the create command and not QSYSVRT. This assists in determining which printing belongs to what source. This may affect some applications that are dependent on the QSYSVRT name. Refer to the individual languages.

The command definition source for both the System/38 environment and OS/400 CRTXXXXPGM commands has been changed to take advantage of the product library support. This avoids the requirement of having the language libraries (for example, QRPGL) on the library list. See "Library" on page 2-16.

The compilation printed output format has changed somewhat for all languages. The messages produced by the System/38 environment products are shown in OS/400 form. See "Supported programs" on page 2-12 for more information about supported programs.

The System/38 licensed program numbers are used so you can relate to the function.

BASIC 5714-BA1

Interactive sessions: The BASIC interactive session differs from System/38 as follows:

- Operational and color changes have been made on the Command Entry and Help displays.
- Help information is available in the System/38 environment, but displays examples of OS/400 syntax (LIB/OBJ).

Printer output: The compilation printed output appears in OS/400 syntax (LIB/OBJ).

Printer spooled file names have changed:

- QBASESSION is used for output created by the OFF LIST command.
- QBASDMP is used for the file created by a call to QBADTREE.
- The source member is used by the COMPILE BASIC and CRTBASPGM commands.
- QBAWRKSPC is used for the spooled file created by the COMPILE command if no name is specified.
- QBALISTP is used for the spooled file created by the LISTP command.

DDM: New support allows DDM access to CICS direct files.

Defaults: The format of the date used when the program is run is in the format described in the job value (set by the job description or CHGJOB) rather than the system value. If the defaults are taken for the job value, the system value determines the format. Therefore, unless you have made a specific change, you will not see any differences.

COBOL 5714-CB1

New support: The AS/400 licensed program is 5738-CB1. It supports two levels.

- The System/38 COBOL is ANSI 74 level. The same level is available in the System/38 environment.
- The AS/400 COBOL is ANSI 85 intermediate level. Differences when converting from the ANSI 74 level are described in Chapter 4.

The format of the date used when the program is run is in the format described in the job value (set by the job description or CHGJOB) rather than the system value. If the defaults are taken for the job value, the system value determines the format. Therefore, unless you have made a specific change, you will not see any differences.

The source member name for the spooled file is used. System/38 programs which read a spooled version (for example, CPYSPLF) may need to be changed.

Unsupported functions and files: The 6346 and 9346 Tape Units do not support read backwards.

Card files are not supported.

PASCAL RPQ 5799-CPK: PASCAL was a PRPQ on System/38 and is a licensed program on the AS/400 system (5738-PS1). No support for PASCAL exists in the System/38 environment. All System/38 PASCAL program objects must be re-created from source on the AS/400 system (restore cannot be used).

PL/I 5714-PLI: The AS/400 licensed program is 5738-PL1.

Card devices are not supported.

The name of the spooled file used for the compilation printed output is the source member specified on CRTPLIPGM.

RPG 5714-RG1: The AS/400 licensed program is 5738-RG1. RPG supports both an AS/400 system version and a System/38 environment version. Using the System/38 environment support, you can update programs migrated from System/38 or create new System/38 environment programs.

The System/38 environment RPG is different from the System/38 RPG in these ways:

- The source member name specified on the create command is used for the spooled file name. System/38 programs that read a spooled version may need to be changed.
- The format of the date used when the program is run is in the format described in the job value (set by the job description or CHGJOB) rather than the system value. If the defaults are taken for the job value, the system value determines the format. Therefore, unless you have made a specific change, you will not see any differences.
- When IGNDDECERR(*YES) is specified in the compiler option of CRTRPGPGM and decimal data that is not valid is involved in an arithmetic calculation, the result may be different between System/38 environment RPG and System/38 RPG.
- Card devices are no longer supported. See the *RPG/400* Reference* for specific information.

To convert using source and re-compilation, you must have all the source members that are used by a /COPY statement.

Differences between the System/38 environment RPG and the OS/400 support are described in Chapter 4.

Chapter 3. Converting from the System/38 Environment to the OS/400 Program

This chapter assumes that you have already made the migration step to the OS/400 program and are using the System/38 environment (for example, running System/38 programs). If you are going to convert directly from System/38 to the OS/400 program, you must also consider the differences outlined in Chapter 1 and Chapter 2.

It is assumed that you are operating the system using the OS/400 program.

Note: It is important to understand the difference between running programs in the System/38 environment and operating the system in the OS/400 program. Running a program in the System/38 environment means that the program was written using System/38 syntax. Operating the system includes such things as using OS/400 syntax to run the system, using OS/400 displays, and handling messages. To convert fully to the OS/400 program, you must convert your programs, job streams, and files that are operating in the System/38 environment.

Overview

Normally, you convert gradually to the OS/400 program. It is not necessary that you convert all at once or that you convert everything. The advantages of making the conversion are:

- Less confusion in switching back and forth between System/38 and AS/400 syntax, command names, and function keys
- The ability to take advantage of OS/400 function without embedding it in System/38 environment programs

Note: There is no significant performance advantage in converting to the OS/400 program.

You need to consider the following items:

- Control language (CL) programs and job streams
- Files and data management changes
- High-level languages
- Data file utility (DFU) and Query

In the following discussion, it is assumed that the functions are correctly operating in the

System/38 environment. This means that you have made any changes necessary to successfully migrate.

CL Programs and Job Streams

There is no real difference in conversion for job streams versus CL programs. However, if your job streams are entered from diskette or some other form other than database members, you must access the source and convert it.

You must re-create the CL programs. You may need to make modifications to some of the source before you can re-create the programs.

Converting CL source: The CVTCLSRC command is designed to assist you in converting CL source. It requires your source to be in database source members. CVTCLSRC reads the commands in a source member and writes the converted commands to another source member (it does not re-create the CL program). A single member, a list of members, or all members in a file can be converted on each use of CVTCLSRC. The CVTCLSRC command converts the source statements for the simple types of changes including:

- Conversion of qualified names whether they are literals or variables. For example:

System/38 Environment	AS/400 Conversion
PGM(PGMX.LIBY)	PGM(LIBY/PGMX)
PGM(&PGM.&LIB)	PGM(&LIB/&PGM)

- Conversion of command name, keyword name, and keyword value changes. For example:

System/38 Environment	AS/400 Conversion
DSPJOBQ	WRKJOBQ
OUTPUT(*LIST)	OUTPUT(*PRINT)
PUBAUT(*OPER)	AUT(*USE)

- Conversion of comments. Different rules govern what is a valid comment. See "CL" on page 4-2.

If the original source statement width can be completely displayed on the SEU display, the re-created source also fits on the SEU display. Thus, if you normally see your complete source statements without using windowing in SEU, the re-created source is shown in the same way.

If the CVTCLSRC command makes a change to a command, it always inserts keywords for the parameters you have specified. Consequently, you may see more lines of source created than your existing source. If a source statement is changed, it will appear formatted in a manner similar to the way SEU returns a prompted command. If you normally indent for DO loops, the CVTCLSRC command output will appear differently if a change has occurred. If a statement is not changed, it is shown as it originally was with the same definition.

CVTCLSRC (or a manual conversion of just command changes) cannot do a complete conversion because some programs are written using variables. For example, if you specified

the following, the source would convert without error.

```
CHGVAR  &TYPE '*LIST'
DSPOUTQ QPRINT OUTPUT(&TYPE)
```

The program would fail, however, when it is run because *LIST is no longer a valid value for the OUTPUT parameter on the OS/400 WRKOUTQ command.

Other functions you need to review are the use of the QCAEXEC or QCACHECK programs. These functions have been replaced by QCMDEXC and QCMDCHK. Because you pass the entire command as a parameter to these programs, you need to ensure that the command is in OS/400 syntax if you change to QCMDEXC and QCMDCHK.

Note: It is not required that you change from the use of QCAEXEC and QCACHECK.

You can have an OS/400 program that issues a call to a System/38 environment program, or you can use QCAEXEC as follows:

CL Program Type=CLP

```
•
DLTPGM LIBB/PGMA
•
•
CHGVAR &CMD 'CALL PGMX.LIBY'
CALL QCAEXEC PARM(&CMD 500)
•
```

**PGMX Type=XXX
or XXX38**

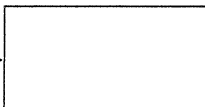

RV2W324-0

In this case, the OS/400 CL program uses a call to QCAEXEC even though it may be calling an OS/400 program. Thus, if you have a complex System/38 command that is used in QCAEXEC, you can continue to use the same specifications in most cases.

Note: CVTCLSRC does not convert the names of the programs QCAEXEC and QCACHECK nor the values in the parameters passed. You must manually convert these to QCMDEXC and QCMDCHK.

CVTCLSRC does not convert the CRT and CHG device configuration commands. You must convert these manually to the new commands required on the AS/400 system.

CVTCLSRC does not convert qualified field names such as those found in the OPNQRYF command for the parameters QRYSLT, GRPSLT and MAPFLD.

Minor changes exist relative to the number of parameters that can be entered positionally (without keywords) for some OS/400 commands. This may prevent a few System/38 commands from being properly converted by CVTCLSRC.

Commands: For the list of differences by command, see Appendix A.

Commands using the System/38 environment DFU and Query (for example, CHGDTA and QRYDTA) must be fully qualified (for example, QSYS38/CHGDTA) if you intend to use the System/38 environment version.

Parameters: The values of the defaults are changed for some parameters. The most significant changes are:

- The default for create commands changes from QGPL to the current library. If the user profile has *CRTDFT as the current library, no change is needed (QGPL is used). If, however, you change the user profile value, you must consider the following:
 - The effect on the CRT commands that do not specify a library.
 - The effect on the library list caused by the current library. See the discussion in Chapter 1.
- The following SBMJOB defaults are changed:

- The JOBD parameter uses *USRPRF as a default instead of QBATCH.
- The INLLIBL parameter uses *CURRENT as a default instead of *JOBID.
- The OUTQ parameter uses *CURRENT as a default instead of *JOBID.
- The RTGDTA parameter uses QCMD38 as a default instead of QCMD38. (The System/38 default was *JOBID, but the default in the System/38 environment is QCMD38.)

The CVTCLSRC command will not insert values to make the program identical to the System/38 environment. In the example that follows, the new defaults for the OS/400 SBMJOB command will be used.

System/38	
Environment Source	SBMJOB RQSDTA('CALL PGMA')
Converted Source	SBMJOB RQSDTA('CALL PGMA')

If the RQSDTA had been ('CALL PGMA.LIBB'), the batch job will fail because OS/400 syntax is assumed. Since a period is a valid character in a name, the system would try to call the program '*LIBL/PGMA.LIBB'.

To properly convert, you need to manually inspect each CRT and SBMJOB command. To assist in finding these commands, you could use one of the following commands:

- LSTCMDUSG
- SCNSRC in QUSRTOOL, as described in "Files and Data Management Changes"

Files and Data Management Changes

Not all files need to be converted. When files are migrated to the AS/400 system that were not created directly from source, they are marked as OS/400 files (for example, PF). If a file is created using CRTDUPOBJ, the DSPOBJD information of the new file does not reflect the original source file or member. However, the file type reflects the type (such as PF38) from which it was duplicated.

You can use the OS/400 CHG commands against either an OS/400 program or a System/38 file. For example, you might want to specify new print file attributes that are only available using the OS/400 CHGPRTF command even though the file type is PRTF38.

A System/38 program can access either a System/38 or an OS/400 file. Similarly, an OS/400 program can access either a System/38 or OS/400 file.

Many of the file conversions require only a simple re-creation from the existing source. In some cases, source changes are required.

No system support command exists for converting files. A command is supplied in the QUSRTOOL library to assist in conversion of DDS source. See the tool CVTDDSSRC command. It is modeled after the CVTCLSRC command. CVTDDSSRC converts the DDS source to a different file. You must issue the create command because OS/400 syntax is assumed.

Physical files: Physical files generally have little conversion required to make them OS/400 files (consider the change to FIFO sequencing discussed in Chapter 4, however). In general, you should be looking for the use of qualified names in DDS. Appendix B has a list of the keywords that allow qualified names.

The OS/400 program does prevent a physical file from being created that used the FORMAT keyword to specify a format in a logical file.

Assume you want to manually convert the DDS source for a typical physical file. You would normally use the Programmer Menu or PDM and specify the OS/400 type of PF instead of the System/38 environment type of PF38. You could use the SEU scan function to scan the source looking for the use of a period as the separator for qualified names. For example, assume you have used the REF keyword as:

```
REF(FILEX.LIBY)
```

You need to change this to:

```
REF(LIBY/FILEX)
```

If you had used the unqualified form or the unqualified form with a format name, you would not need to change. For example:

```
REF(FILEX)  
REF(FILEX FORMAT1)
```

would not need to be changed.

Instead of using SEU to scan individual source members, you could have a scan program look for periods in all of the DDS source. A command is supplied in the QUSRTOOL library for general source scanning. See the TAA tool SCNSRC command.

Note: Scanning for a period finds the qualified names that must be changed, but may also find decimal points (for example, in edit words and comments) that should not be changed.

As on System/38, whenever you prepare to replace a physical file you must remove the dependencies (for example, logical files and journaling) and copy the data in the existing file.

Logical files: For qualified name use, see the discussion under "Physical files." For ACCPTH keyword change, see the discussion on "Data Description Specifications (DDS)" on page 4-4.

Display files: The use of the DSPSIZ keyword with types *DS1 and *DS2 is not supported. These are for the System/38 console (16-by-64) and (12-by-80) display that is not supported on the AS/400 system.

The RTGXXX keywords are not supported.

No changes have been made to the return codes used between the System/38 environment and the OS/400 program. See "Return Codes" on page 2-35 for the changes from the System/38 to the System/38 environment.

For qualified name use, see the discussion under "Physical files."

Printer files: No changes have been made to the return codes used between the System/38 environment and the OS/400 program. See "Return Codes" on page 2-35 for the changes from the System/38 to the System/38 environment.

For qualified name use, see the discussion under "Physical files."

Communication files: The System/38 forms of BSCF, CMNF, and MXDF are not supported in the OS/400 program. The files must be converted to the new ICF file. For the most part, the DDS conversion effort is the same as it is for a database file.

Return codes: Return code differences may cause differences for the programs that are using the file. In the System/38 environment, the return codes are mapped to the definition used on System/38. In the OS/400 program, new return codes exist and changes to the old codes have been made.

See “Return Codes” on page 4-13 and “Data Description Specifications (DDS)” on page 4-4.

Languages

In general, most of the programs convert to the OS/400 program without the need to make any source code changes. For most programs, the program need only be re-created using the OS/400 CRT command. An automated conversion of high-level language source programs is not supported. See “Mass Changes of Source Types” for a discussion of mass changes of source types.

COBOL programs may require some changes to convert from the ANSI 74 version to the ANSI 85 intermediate level.

To convert fully to an OS/400 program, look for calls to QCAEXEC and QCACHECK, and convert these to QCMDEXC and QCMDCHK, respectively. If you are using a qualified name syntax in the command being passed as a parameter, change the syntax.

It is not required that you change from the use of QCAEXEC and QCACHECK. You can have an OS/400 program that issues a call to a System/38 environment program or, as stated for CL programs, you can use QCAEXEC to call an OS/400 program.

A typical use for QCAEXEC in a high-level language program is to issue an OVRDBF command so that the file can be opened multiple times within the same program using different open parameters (for example, a different member). If you are using a qualified name, you must convert to OS/400 syntax if you convert to QCMDEXC.

See also the comments described in processing of message text in the “CL” on page 4-2.

If your language supports and you use qualified names, convert these (for example, COBOL copy statements and the RPG /COPY function).

Data File Utility (DFU)

Converting from the System/38 environment data file utility (DFU) to the AS/400 Application Development Tools DFU is not supported. You must create a new AS/400 DFU manually.

Not all functions in the System/38 environment DFU are included in the AS/400 DFU. Depending on your use of DFU, you may need to keep the System/38 environment version. A list of differences is in Chapter 4. The following are a few of the significant items that are not included in the AS/400 DFU:

- Retrieving of source
- Batch creation commands
- Validity checking
- Verify mode

Query

Converting from the System/38 environment Query to the AS/400 Query is not supported. You must create a new AS/400 Query manually.

Not all functions in the System/38 environment Query are included in the AS/400 Query. Depending on your use of Query, you may want to keep the System/38 environment version. A list of differences is in Chapter 4. The following are a few of the significant items that are not included in the AS/400 Query:

- Tables
- Retrieving of source
- Batch creation commands
- Record sampling
- DDM support

Mass Changes of Source Types

For some of your source files, you may prefer to change the source types of all or specific source types and then try to create the objects without making any preliminary changes to the source statements. For example, many high-level language programs require only a re-create with

the proper source type. There are two ways to achieve this:

- SEU and PDM allow a display of member lists where you can change the source type manually.
- A QUSRTOOL command exists named CHGSRCTYP that allows a batch method of changing all or specified source types in a file.

Chapter 4. Changes Needed to Convert to the OS/400 Program

This chapter describes the changes needed to convert from the System/38 environment to the OS/400 environment support; you should have already migrated to the System/38 environment. If you are converting directly to the OS/400 program, also see Chapter 1 and Chapter 2.

No hardware changes must be made between the System/38 environment and the OS/400 program.

Not all new programming functions are described. In some cases, new OS/400 functions are mentioned to assist in your understanding. Specific command changes are described in Appendix A. These affect many of the OS/400 functions discussed in the following pages.

For some functions (for example, recovery and PC Support/400), no special System/38 environment support exists. This means the commands and functions are only in QSYS. If this is the case, the section in this chapter is described as the *OS/400 program only*.

General

Several changes have been made to commands where different verbs are used, keyword names have changed, or keyword values have changed. Appendix A lists the changes by command. Most of these changes are not described in this chapter. However, the highlights of the changes are as follows:

Verbs: Some command verbs have been changed. Most System/38 verbs of STR, BGN, DFN, and ENT have been standardized to STR. Most System/38 verbs of END, TRM, CNL, and STP have been standardized to END. The LST verb becomes PRT.

Current library: The CRT commands use the defaults to create the object into the current library (*CURLIB). (Most System/38 commands used QGPL as the default.) The current library concept allows you to designate a library for created objects that do not specifically describe a library.

Display and work commands: Most DSP commands that allow changes have been changed to the verb WRK. Other WRK commands exist to allow a set of functions against a particular object type (for example, WRKJOBDD).

The DSP and WRK commands that support the OUTPUT parameter have changed to use a value *PRINT instead of *LIST.

Outfile support: Commands which support an outfile have changed from OUTPUT(*NONE) to OUTPUT(*OUTFILE).

Authority: The commands using the keyword PUBAUT have been changed. The new keyword is AUT and the values have changed as follows:

System/38 Environment	AS/400 System
*NORMAL	*CHANGE
*OPER	*USE
*NONE	*EXCLUDE

The same values also exist on the GRT/RVKOBJAUT commands.

Calls: Any calls to QCAEXEC, QCACHECK, or QCL should be changed to QCMDEXC, QCMDCHK, and QCMD. The syntax of the parameters being entered to QCMDEXC and QCMDCHK must adhere to the OS/400 program. The calls can be made from CL or any high-level language programs. See Chapter 3 for a discussion of when it is not necessary to change.

Operating System/400 Program

Access Paths: With the exception of the change in the default sequence described in the "Database" on page 4-3, no changes are necessary from the System/38 environment. Access paths do not need to be re-created to operate with OS/400 programs. If the file is specified as System/38, re-creating the file as the OS/400 program results in a rebuilding any access path unless access path sharing results.

Address regeneration: Address regeneration is performed automatically at each IPL. See "Initial Program Load (IPL)" on page 2-13.

Alerts: Alerts can be displayed on the AS/400 system with the new WRKALR command.

Support to define a sphere of control and to display the status (see the WRKSOC and DSPSDCSTS commands) has been added.

The *Alerts and DSNX Guide* contains more information. See also "Network Attributes" on page 2-22 and "Message Handling" on page 2-19.

APPC: No changes are needed to the device configuration requirements. To use the new APPN support, you must change to APPN(*YES).

See also "Data Description Specifications (DDS)" on page 4-4.

Auxiliary Storage Pools (ASP): Available in the OS/400 program only. All specifications are made using DST.

BSC: The BSC38 file type is not supported. You must convert to the ICF file type. See "Data Description Specifications (DDS)" on page 4-4.

RJE and 3270 device emulation continue to use a BSC file.

Card: Card devices and card files are not supported on the AS/400 system.

Chart Format: No changes from the System/38 environment.

Checksums: Available in the OS/400 program only. All specifications are made using DST.

CL

Syntax: The syntax of a valid comment has changed to avoid conflicts with the new slash separator for qualified names. The beginning of a comment is specified by a */*. It must be preceded or followed by a blank. Two exceptions are made:

*/**...* is always treated as a comment.
*/*AA* where the */* begins in position 1 is always treated as a comment (assuming the previous line did not have a continuation character).

In the following examples a 'b' is used to represent a blank. A valid comment must be one of the following:

*/*b* A blank following the */*
*b/** A blank before the */*
*/*** An * following the */*
*A/*b* A blank follows the */*
*/*n* If the */* begins in position 1, any character can follow the */*. This assumes that the previous line did not have a continuation character.

The following comment is not valid:

*A/*A* No blank prior to or after the */*

The division operator */*, must be preceded by a blank if the first operator is not a constant.

Valid *1/2*
 &A /2
 &A / 2
 &A /&B

Not valid *&A/2* (No blank between the variable and the */*)

OPNQRYF always requires a preceding blank before the division or remainder operator.

Data areas: Commands which work with data areas (DCLDTAARA, SNDDTAARA, and RCVDTAARA) are not supported in the OS/400 program. You must convert to the CHGDTAARA and RTVDTAARA commands.

Convert command: The CVTCLSRC command converts most of the typical kinds of changes such as those described in Chapter 3 for commands, keywords, and values. Appendix A lists the differences by command.

Programs: The CL source must adhere to the OS/400 syntax for qualified names and comments.

When a replacement variable is used to substitute into a keyword of type *NAME, the content of the variable is not folded to uppercase. For example, if you did the following:

```
CHGVAR  &A  'abcde'  
CALL    PGM(&A)
```

The PGM keyword is specified as a name type in command definition. Therefore, the program name to be searched for would be the lowercase name on the AS/400 system. This change is

required to allow for the expanded name rules. Lowercase names are now valid, but if you are converting from the System/38 environment you probably want an uppercase name. See "Naming" on page 4-10.

The maximum size of a character variable has been increased from 2000 to 4096.

Command changes are described in Appendix A.

Convert date: The CVTDAT command allows a new option of *JOB on several parameters. This allows access to the job date format and separator character, as described in "Work Management" on page 2-60.

Class Object: Other than the command changes described in Appendix A, no changes are required from the System/38 environment.

Command Definition: Appendix A describes the command changes. The command definitions have a change in the ordering of prompts for qualified names. In general, this will probably not require a change. See the discussion in Chapter 2.

Commitment Control: Other than the command changes described in Appendix A, no changes from the System/38 environment are needed.

Communications: Specific communications topics are covered elsewhere in this manual. See the sections on:

- "Alerts" on page 4-2
- "APPC" on page 4-2
- "Data Description Specifications (DDS)" on page 4-4
- "Emulation (3270)" on page 4-7
- "Exchange ID" on page 4-7
- "LU-1" on page 4-10
- "Object Distribution" on page 4-11
- "Pass-Through" on page 4-11
- "RA/DHCF" on page 4-13
- "Return Codes" on page 4-13

"SNADS" on page 4-14

"X.25" on page 4-16

Communications Configuration: Available in the OS/400 program only.

Communications File: The CMNF38 is not supported in the OS/400 program. See "Data Description Specifications (DDS)" on page 4-4.

RJE and 3270 device emulation continue to use a communication file.

Console: No changes from the System/38 environment.

Copy File: Other than the command changes described in Appendix A, no changes from the System/38 environment are needed.

Cross-Reference: In the QAFDPRT outfile, the field PRDRAW contains the System/38 environment version of the DRAWER parameter value, and the field PRDREN contains the OS/400 version of the DRAWER value. Change PRDRAW references to PRDREN.

Customer Support: Available in the OS/400 program only.

Data Area: Changes to data area commands are discussed in "CL" on page 4-2. Other command changes are described in Appendix A.

Database

DDS: DDS use of qualified names must adhere to OS/400 syntax rules.

DBCS types: Two new DDS data types are supported for physical and logical files in the OS/400 program for DBCS systems. The new data types are E (DBCS Either) and J (DBCS Only). The existing DBCS data type O (DBCS Open) is still supported. The REFSHIFT keyword is not allowed on the E or J data types nor is it allowed on the O data type in the OS/400 program.

Concatenation of DBCS fields is allowed in the OS/400 program. The resulting data type is as follows:

Fields	Result
O, J or E with O, E, A, S, P, B	→ O (DBCS-Open)
J with J	→ J (DBCS-Either)
O, J, E, A, S, P, B, or H with H	→ H (Hexadecimal)

OPNQRYF: OPNQRYF use of qualified names must adhere to OS/400 syntax rules.

The OPNQRYF division operator '/' and the remainder operator '%' must be preceded by a leading blank.

OPNQRYF supports the %DIGITS function for converting decimal data directly to character format. The System/38 solution requires two steps (convert to zone and then convert to character).

Sharing: On System/38, implicit sharing is the default for access path sharing, but constraints exist, such as the makeup of the keys and selection specifications.

A change has been made on the AS/400 system to allow more situations where implicit access path sharing can occur. To achieve this, the default for access path sequencing has been changed.

On System/38, the files default to run in a first in, first out (FIFO) sequence. When a file is converted from System/38, FIFO is also assumed. If you create a System/38 file on the AS/400 system (for example, type LF38), it also assumes a default of FIFO sequence.

For file types in the AS/400 system, the default is no specific sequence. A new keyword exists for FIFO sequence.

For example, on System/38 if you had an access path with the key on DEPT and EMPLOYEE and no selection specifications, a new logical file would not share this access path if its key requested only DEPT. On the AS/400 system, the new file shares the access path. This assumes that no selection specifications exist on either file (or is the same or DYNSTL is used) and one of the following:

- The new file takes the default.
- Both files specify FIFO.
- Both files specify LIFO.

Note: For an OS/400 file, the default is to share an access path with any file (LIFO or FIFO) with matching keys or partial keys. Consequently, some of the AS/400 files that you create may share an access path with a System/38 file.

Because of this change, the function of explicitly shared access paths is being dropped. This also results in the removal of the ACCPTHMBR parameter on the CRTLF and ADDLFM commands. The ACCPTHMBR parameter is ignored if the file is created or if the member is added in the System/38 environment.

If you re-create files using DDS source, you must be aware of the type of sequence you require and specify FIFO if appropriate. In general, you should change your DDS to FIFO if you have duplicate keys and the order of the duplicates is important.

For unique keyed files, the use of FIFO or LIFO is meaningless.

To assist in your conversion, the FIFO keyword can be used in System/38 environment source. A warning message occurs because FIFO is assumed for System/38 files.

In the OS/400 program, the ACCPTH DDS keyword is replaced with the REFACPTH keyword. REFACPTH functions the same as ACCPTH in the System/38 environment, except that some restrictions have been lifted.

New commands: The new command POSDBF allows setting the file cursor position to the start or end of file. This is of value when using OPNQRYF and you want to reprocess the file with multiple programs or read backwards from the end of the file.

See the new CHKRCDLCK command described in "Group Jobs" on page 4-7.

Data Description Specifications (DDS)

Database functions: For database files, the ACCPTH keyword has been replaced and new data types and functions have been defined for DBCS fields. See "Database" on page 4-3.

Qualified names: Qualified names must be in OS/400 syntax. Appendix B has the list of the keywords that support qualified names.

ICF: The BSCF38, CMNF38, and MXDF38 types are not supported. For BSCF38 and CMNF38, a conversion must be made to the ICFF type. For MXDF38, a conversion must be made to either or both DSPF or ICFF types. For the most part, the DDS conversion effort is minimal. With the exception of a few keywords, the keywords used in the System/38 file types are valid in the ICFF file type.

The changes needed are:

- You must be sure that your program is handling the return codes used by an ICFF file. This is not a change to your DDS specifications, but may be a change to your program. See "Return Codes" on page 4-13.
- The following keywords have been renamed:

System/38

Environment	AS/400 System
RCVCFM	RCVCONFIRM
TRNRND	RCVTRNRND

- The RTGXXX keywords are not supported for OS/400 files.

Most of the information from these keywords can be found in the I/O feedback area.

- The new ICFF file type does not support the System/38 mixed file function of allowing a display device and a communications device in the same file. Some uses of this support can be converted to a display file and an ICFF files. If your application is performing a common wait on either device having input, you should consider the continued use of the mixed file.
- For an APPC application, there is no default positive response to a received confirm request. Use the new RSPCONFIRM keyword to positively respond to the CONFIRM request if needed.
- Device entries are added with separate commands and are not on the CRTICFF command. The support on the AS/400 system is similar to the approach used with the mixed file on System/38. The ADDICFDEVE command is used to add the device entry after the file is created.

- On System/38, a record format had to contain at least a field or the EVOKE keyword. This is no longer a restriction in ICFF.
- Additional error checking is performed on the source.
- A record format name in an ICF file cannot begin with '\$\$'.

Check for valid name: CHECK(VN) checks for a valid name using the System/38 syntax rules. A new keyword, CHECK(VNE), allows checking against the extended names.

Editing date: The EDTCDE keyword Y value uses the date format and date separator from the job attributes rather than from the system value. If you do not change the job attribute, the function operates like it did in the System/38 environment.

Help support: New keywords define help information provided externally to the user application. When the Help key is pressed, the system determines the action to perform based on the keywords specified.

DDS files containing the HELP keyword are not changed if they are re-created (control is passed back to the program when the key is pressed).

The new keywords are specified to control the action that occurs when the Help key is pressed for a particular format. A file can have some formats with the new support and some that use the System/38 support (return to the program).

When the new support is used, you can control which help information is shown based on where the cursor is positioned on the display when the Help key is pressed. Keywords are used to define help areas on the display (a beginning and ending row or column). A default area can also be described.

If you have a subfile, the HELP keywords must be specified on the subfile control record. Multiple columns can be defined on the display so that if the Help key is pressed within one of the columns (such as in the subfile record), the appropriate help information can be displayed.

When the new support is used, your application program is not aware that the user has

requested help. The function is performed by work station data management.

When the user requests the new help function, the current display is saved and the help information is shown. When the help function is ended by the user, the original display is restored as well as the cursor (the cursor is restored to the location where it was when the Help key was pressed). You have a choice of how to create user-defined help information. This can be in the form of:

- One or more display formats. The format can be in the same or a different display file. When help information is displayed and the paging keys are pressed, additional help information can be displayed. The information is dependent on DDS keywords and the help specifications.
- A document. A single document can contain help information for many functions. Labels within the document identify sections which can be directly accessed by DDS keyword specifications.

The *DDS Reference* manual and the *Guide to Programming Displays* contain more information.

Display file function: Some enhancements have been made to display file function; see "Data Description Specifications (DDS)" on page 6-4.

The routing keywords are not allowed. See Appendix A for a list of these keywords.

Data Queue: Other than the command changes described in Appendix A, no changes from the System/38 environment are required.

Debug: Other than the command changes described in Appendix A, no changes are required from the System/38 environment. "Debug" on page 2-7 describes the change of authority for what is required to debug a program. The default for the program create commands is *CHANGE which allows debugging. To prevent debugging specify *USE.

Dedicated Service Tools (DST): No changes from the System/38 environment.

Device Configuration: Available in the OS/400 program only.

Device Files: Refer to "Files" on page 4-11, "Display Files" and "Data Description Specifications (DDS)" on page 4-4 for the specific device file.

Diskette

Parameters and commands: The LOC parameter is not supported in the OS/400 commands (no magazine exists).

CPYFRMDKT and CPYTODKT have a different positional parameter order.

The OS/400 commands allow the support of multiple diskette devices.

DUPDKT supports an input and output diskette being different and also allows multiple copies.

Display Commands: See "Display Commands" on page 2-10.

Display Files: See "Data Description Specifications (DDS)" on page 4-4.

Display Format: No changes from the System/38 environment.

Distributed Data Management (DDM)

Replacing a System/38 with an AS/400 system: A change may be required for the systems communicating with a System/38 if the System/38 is replaced with an AS/400 system. This is discussed in Chapter 5.

Remote location name: The DDM commands support a new parameter RMTLOCNAME. See "Remote Location Name (RMTLOCNAME)" on page 2-28.

New parameters are required for the local location name and the remote network ID.

Refer to the *DDM Guide* and the *OS/400* Communications Configuration Reference* for a description of this support.

When a DDM file is created in the System/38 environment or migrated from System/38, the RMTLOCNAME function defaults to *DEV. In the OS/400 program, the CRTDDMF command

requires that you enter a name for the RMTLOCNAME parameter. However, the CHGDMMF command allows the use of RMTLOCNAME(*DEV). This allows you to use the WRKDDMMF command to display a list of the DDM files created in either environment and still use the default for RMTLOCNAME.

Database files: A database file can be created, renamed, or deleted on a remote system.

MODE value: The MODE value of *FIRST is not supported in the OS/400 command. If the value is specified on the System/38 environment, it is translated to the new *NETATR special value.

Edit Descriptions: Other than the command changes described in Appendix A, no changes are required from the System/38 environment.

Emulation (3270): The 3270 Pass-Through function is standard in the OS/400 program for the STREML3270 command to a remotely attached 3270 Display Station.

Changes in commands and parameters exist. See Appendix A.

Additional keyboard types are supported.

Error Handling: See "Return Codes" on page 4-13.

Exchange ID: Available in the OS/400 program only. See "Exchange ID" on page 5-1.

Files: See "Database" on page 4-3 and "Data Description Specifications (DDS)" on page 4-4.

Finance: Other than the command changes described in Appendix A, no changes are needed from the System/38 environment.

Graphical Data Display Manager

(GDDM): No changes from the System/38 environment.

Graphics Symbol Set: Other than the command changes described in Appendix A, no changes are required from the System/38 environment.

Group Jobs: The new Check Record Lock (CHKRCDLCK) command can be used to determine if any record locks exist in the current job. This can be used to prevent transferring to a different group job in the middle of a complex transaction.

Other than the command changes described in Appendix A, no changes are required from the System/38 environment.

Help: IBM displays that provide help text remain the same in the OS/400 program. IBM-supplied OS/400 commands provide help information. User written help functions for application are now supported.

See "Data Description Specifications (DDS)" on page 4-4.

IBM-Supplied Programs: The System/38 environment programs are replaced by the OS/400 programs as shown in Figure 4-1. The System/38 environment programs (for example, QCAEXEC) exist in QSYS (not in QSYS38) and may still be used in the OS/400 program if System/38 syntax is needed.

System/38 Environment	AS/400 System	
QCL	QCMD	Command entry
QCAEXEC	QCMDEXC	Run a command from a string
QCACHECK	QCMDCHK	Validity check a command

Intersystem Communications Function

(ICF): New commands include:

Add ICF program device entry	ADDICFDEVE
Change ICF program device entry	CHGICFDEVE
Change ICF file	CHGICFF
Create ICF file	CRTICFF
Delete override ICF device entry	DLTOVRDEVE
Override ICF device entry	OVRICFDEVE
Override ICF file	OVRICFF
Remove ICF device entry	RMVICFDEVE

The *ICF Programmer's Guide* contains specific information.

See "Data Description Specifications (DDS)" on page 4-4.

Initial Program Load (IPL): Available in the OS/400 program only.

Install: Available in the OS/400 program only.

Independent Work Station Support: This is now called PC Support/400 and is available in the OS/400 program only.

Jobs: See "Naming" on page 4-10. No other changes are needed from the System/38 environment.

Job Accounting: Other than the command changes described in Appendix A, no changes are required from the System/38 environment.

Job Descriptions

LOG parameter: LOG(4 0 *NOLIST) is used instead of the System/38 default of (1 10 *MSG). This causes more logging during the job, but no logging if the job completes normally. No performance loss is experienced while the job is running using the logging level (4 0 *NOLIST) versus the System/38 default. Job log processing does not occur until job completion and the *NOLIST entry is very efficient at normal job completion.

RTGDTA parameter: The job description default is RTGDTA(QCMDI) instead of (QCMDB). This works in conjunction with the SBMJOB and BCHJOB defaults which have changed to RTGDTA(QCMDB). The RTGDTA values are designed to allow both interactive and batch jobs to use the same job description and cause a different routing entry to be selected in the sub-system. If the defaults are taken, interactive jobs can be sensed by the QCMDI routing data and batch jobs sensed by the QCMDB routing data.

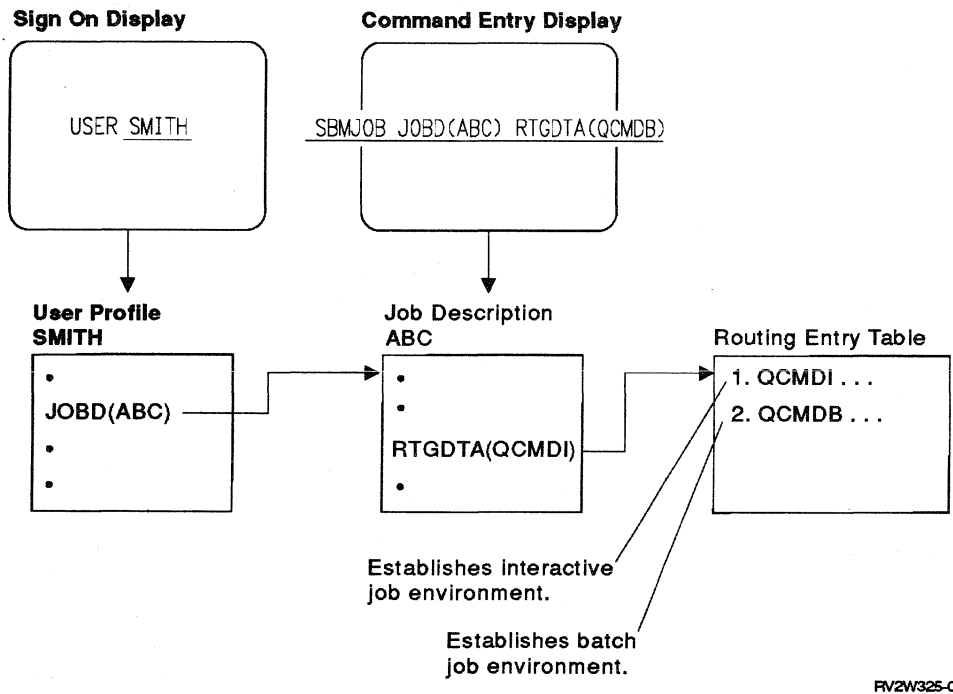

RV2W325-0

Figure 4-1. Using the RTGDTA Parameter

In Figure 4-1, SMITH signs on and uses the job description ABC that is specified in his user profile. The QCMDI routing data is used to determine the subsystem routing entry to be used. In this case, the routing entry establishes an interactive environment.

When SBMJOB is used by SMITH, the defaults can be taken for both JOBID and RTGDTA. In the example, they are shown with the default values specified. This causes the second routing entry to be used which establishes a batch environment.

The SBMJOB command would normally be specified as:

```
SBMJOB  CMD(XXXX)
```

User profile job description: The system support is now designed to encourage the use of a job description assigned to a user profile. The JOBID parameter in a user profile has the default value of QDFTJOBID in QGPL. The default value for the ADDWSE JOBID entry is *USRPRF which allows a job description to be assigned when signing on.

The default for the SBMJOB JOBID parameter has changed to use the JOBID assigned to the user profile. You may want to specify unique job descriptions for certain user profiles and specify unique requirements for such things as library list and priorities. You may also want to tailor the QDFTJOBID job description in QGPL. As on System/38, the CHGJOB command can be used during a job to change the values.

Job Queue: A new job priority of 0 can be used to move a job to the top of the job queue.

Job Streams: To convert a job stream, the System/38 environment command JOB must be changed to BCHJOB. The default for the JOBID parameter will cause all of the other commands in the job stream to be syntax checked for the OS/400 environment.

The ENDJOB command from the System/38 environment has been changed to ENDBCHJOB. It is important that ENDJOB be changed in any job streams which are converted because the ENDJOB command is the valid new spelling for the System/38 environment CNLJOB command.

Journal: See "Programs" on page 4-12 for a discussion of how the replace entry affects journal entries.

Other than the command changes described in Appendix A, no changes are required from the System/38 environment.

Library

Current library: The default for most create commands changes from QGPL to the current library. If the user profile has *CRTDFT as the current library, no change is needed. If, however, you change the user profile value, you must consider two things:

- The default for CRT commands that do not specify a library is the user profile value.
- The current library affects the library list. The sequence of the library list is:
 - System portion (for example, as set by the QSYSLIBL system value)
 - Product library #1
 - Product library #2
 - Current library
 - User portion (for example, as set by the CHGLIBL command)

Because many user CL statements specify an unqualified object name, the library list is often used to find objects. Specifying a current library can cause a change in the library in which an object is found.

You can specify the same library name in both the current library and in either the system or user portion. The typical approach for converting to the current library would be to specify the library, which is normally first in the user portion. Because no error occurs if the current library is also in the user library portion, you do not have to immediately change the user portion to take advantage of the current library approach.

Product library: This allows commands to designate a library that appears on the library list for the duration of the command. (See Chapter 2 for more information.) This is of particular value in that it avoids the need to have libraries like QRPGL or QCBL on either the interactive library list (for use by SEU syntax checking) or in the batch library list (for use by

high-level languages compilations). User commands can also specify the PRDLIB keyword in command definition.

The second product library is only supported for internal IBM functions. There is no user access to this value.

There are implications for both the current and product library functions relative to writing secure functions. An example on how to write a secure program can be found in the *CL Programmer's Guide* and *Security Concepts and Planning*.

Commands: The DSPOBJD uses *LIBL as the default instead of *USRLIBL. This will assist in searching for object types that can only be found in QSYS.

The EDTLIBL command is available to provide a simple prompt to change the current library list.

QUSRTOOL: The QUSRTOOL library is optionally installable as option 7 of the base operating system. The library contains examples of various tools that can assist you with functions, such as applications development and system management. The tools are in multiple source files. The source file named QATTINFO contains the documentation for all the example tools. To use the tools, browse the general documentation. For example, use the command:
STRSEU SRCFILE(QUSRTOOL/QATTINFO) SRCMBR(AAAMAP)

Logs: Other than the command changes described in Appendix A, no changes are required from the System/38 environment.

LU-1: LU-1 is not supported using ICF. If you need ICF support, you should consider converting to the SNA Upline Facility (SNUF) or APPC.

RJE and 3270 Device Emulation continue to use LU-1 support.

Menu: You may want to take advantage of the new menu object capability. See the command CRTMNU. Even if you have existing menus that are created by CL programs and display files, you can specify them on the CRTMNU command. You can then use the GO command to make your menus appear like IBM menus.

Most of the IBM menus are created by new internal support. This support is not available for user menus. However, the CRTMNU command allows menu objects to be created so the end user can access either an IBM or user menu with the GO command.

Message Handling

Sending messages: The SND commands support new parameter values to allow sending a message to QSYSOPR. The SNDMSG command can be used to send a message to all active users. A new keyword allows sending a message to a user message queue. A message can also be sent to *REQUESTER meaning the interactive user for interactive jobs and QSYSOPR for batch jobs.

Messages to active users: A new function exists on the AS/400 SNDMSG and SNDPGMMSG commands to allow the message to be sent to all active users (the user message queue is used). To send a break message to all active users, see the SNDBRFACT command in QUSRTOOL.

Second level message length: The length of the second-level message text has increased from 1435 to 3000 bytes.

Changing message descriptions: An option for the WRKMSGD display allows retrieving the current message description information for the CHG command parameter values. This allows a much simpler approach to changing message text.

Mixed File: The MXD file type is not supported. Communications functions must be converted to the new ICF file type. Display functions must be converted to a display file type. See also "Data Description Specifications (DDS)" on page 4-4.

Naming

Syntax: The syntax of qualified names has changed (as described in Chapter 1). The separator character is a slash instead of a period and the order has been reversed. The syntax for an unqualified name remains the same (for example, CALL PGMX). This affects the following:

- Object names

System/38 environment OBJ.LIB
AS/400 system LIB/OBJ

- Job names

System/38 environment JOB.USER.JOBNBR
AS/400 system JOBNBR/USER/JOB

- Field names (for example, OPNQRYF)

System/38 environment FIELD1.FILEA
AS/400 system FILEA/FIELD1

Extended names: New support allows the use of extended names. This includes the use of lower-case letters, and names beginning with digits and special symbols. This should not affect the conversion from the System/38 environment to the OS/400 program. However, see "Programs" on page 4-2 for a change to *NAME type command parameters.

In general, the use of extended naming requires the use of apostrophes surrounding the name. The *CL Programmer's Guide* contains the full definition of valid names.

Qualified names: Because a period is a valid character in a name in the OS/400 program, a typical error is to fail to convert a System/38 qualified name. For example, assume you have the following System/38 statement in CL source:
CALL PGMA.LIB1

If you re-create the program as an OS/400 type, the program probably fails with an object not found message.

Network Attributes: No changes from the System/38 environment, but the new network attributes can only be used by the AS/400 commands. See "Network Attributes" on page 2-22.

Object Attributes and Source Types: See "Object Attributes and Source Types" on page 2-23. To convert to the OS/400 types, you must re-create the objects that are System/38 types.

Object Distribution: Other than the command changes described in Appendix A, no changes are required from the System/38 environment.

Object Types: No changes from the System/38 environment. You may need to account for the new object types in your programs.

Out Files: Other than the command changes described in Appendix A, no changes are needed from the System/38 environment. A new option exists to allow the output member to be added to or cleared for most commands. New output files have been added for DSPOBJAUT and DSPPTF (this was DSPPGMCHG on System/38).

Output Queue: See "Spool" on page 4-14.

Overrides: Other than the command changes described in Appendix A, no changes are required from the System/38 environment. One of the command changes is to OVRPRTF. This allows FILE(*PRTF) which allow you to override all printer files within the same job. See "Spool" on page 4-14.

Pass-Through: For 3270 Pass-Through, see "Emulation (3270)" on page 4-7.

For 5250 Pass-Through, the OS/400 command STRPASTHR replaces BGNPASTHR. STRPASTHR supports APPN and the OS/400 method of indicating device used in the pass-through by specifying a RMTLOCNAME. (See "Remote Location Name (RMTLOCNAME)" on page 2-28.) If you use multiple systems in the pass-through and have not converted all systems to APPN, STRPASTHR also supports the System/38 interface of specifying the devices, rather than the RMTLOCNAME.

PC Support/400: See "Intelligent Work Station Support 5714-PC1" on page 2-63.

Performance Information: No changes from the System/38 environment.

Printers

Files: Printer files have changed as follows:

- The FORMSIZE parameter is now named the PAGESIZE parameter.
- The SCHEDULE parameter default changes from *JOBEND to *FILEEND.

- On the DRAWER DDS keyword and command parameter, change the value 3 to *E1. In the OS/400 program, DRAWER(3) is used to select the third drawer instead of the envelope drawer.
- For other command changes see Appendix A. See also “Return Codes” on page 4-13 and “Spool” on page 2-48.

Print image: The support is not available on the AS/400 system as it applies to system-attached printers.

Problem Analysis Function: Available in the OS/400 program only.

Problem Log: Available in the OS/400 program only.

Programs: Programs must be re-created to the OS/400 program. Specific references are found in the following sections:

- “Overview” on page 3-1
- “Programs” on page 4-2
- “Languages” on page 3-5
- “Return Codes” on page 4-13
- “Object Attributes and Source Types” on page 2-23

Replace option: A significant enhancement has been made regarding re-creating programs. This function is only available with OS/400 commands. For a replacement of programs that run in a production environment, a clear advantage exists in using OS/400 create commands to achieve this function.

The OS/400 CRTxxxPGM commands support a new option for REPLACE. *YES is the default. If REPLACE(*YES) is requested and the program does not exist, the command works as it does on System/38. If REPLACE(*YES) is requested and the program exists:

- The USRPRF parameter value is copied from the existing program (the parameter value on the CRT command is ignored and the existing program value is used). If the existing program specifies the adopt function of USRPRF(*OWNER), it is correctly replaced.
- The program is compiled into an internal work area.

- If the create step is not successful (serious errors exist), the existing object is left intact and the create command issues an escape message. Thus you can continue to use the existing object.
- If the create step is successful (no serious errors), the existing program is moved to a special library (QRPLOBJ) and given a unique name. In most cases, this allows users who are using the program (have an active version) to continue to use the old version without being aware of the change.
- If the create step is successful, PUBAUT parameter (AUT on the AS/400 commands) is ignored on the CRT command and the existing authorizations are copied to the new object.

Once the new program is created, any new calls to the program use the new version. The support allows the same program to be replaced many times where each version could have multiple users who have an active version. The old versions remain in existence until the next IPL.

While the replace function allows programs to be properly replaced in most cases when they are being re-created, a lock is not placed on a program when it is called (this is the same as System/38). This allows DLTPGM or a restore of the program to occur while the program is in use, which will cause an error message to be sent to any active user of the program.

Creating programs: When creating an OS/400 program, the create commands have a default value of REPLACE(*YES).

When using the Programmer Menu, a message continues to be displayed if a program exists when the create option is requested. Pressing the F11 function key results in a conditional replacement of the program. The program is not deleted immediately the way it was on System/38. If the create is successful, the existing program is deleted and replaced by the new program.

When creating a System/38 program, the create commands have a default value of REPLACE(*NO). Pressing F11 on the Programmer Menu deletes the existing program and then creates the new program. (If the create is unsuccessful, the original program has been

deleted and no replacement program is created.) A similar function occurs when using PDM.

Note: This replace function only operates on program objects. Other object types (for example, display files) must be deleted first.

When REPLACE(*YES) is requested, only two parameters on the CRT command, USRPRF and AUT, are ignored. All other parameter values are taken from the CRT command. Thus, options like the CRTRPGGM command with the IGNDECERR parameter must be specified.

Note: If you have a program in existence and wish to change the USRPRF attribute, you must use either the CHGPGM command or delete the program and re-create it. Similarly, if you want to change the authorizations, you may do so by the GRTOBJAUT and RVKOBJAUT commands or delete the program and re-create it. If you are journaling files used by a program that is replaced, the new journal entries will reflect the date and time stamp program name for those users who remain active to the replaced version.

REPLACE(*NO) operates differently when using PDM or the Programmer Menu. If REPLACE(*NO) is requested on the AS/400 commands and the program exists, the same type of processing occurs as if REPLACE(*YES) has been specified. Both PDM and the Programmer Menu will implicitly change the request to REPLACE(*YES).

Observability: A new option on CHGPGM allows the observability of a program to be removed. This removes the program template of the program which significantly reduces the size of an object program. However, the following functions are lost when observability is removed:

- Display or change program variables under debug
- Formatted dump on execution errors
- Restore a program to a previous release

Programmer Menu: Other than the command changes described in Appendix A, no changes are needed from the System/38 environment. You should consider using the programming development manager instead of the Programmer Menu.

Programming Changes: Referred to as programming temporary fix (PTF) on the AS/400 system.

Prompter: The prompter support is only available in the OS/400 program. However, it can be used to see prompts for System/38 environment commands.

Programming Temporary Fixes (PTFs): Available in the OS/400 program only.

RA/DHCF: Other than the command changes described in Appendix A, no changes are required from the System/38 environment.

Recovery: Available in the OS/400 program only.

Remote Location Name

(RMTLOCNAME): See "Remote Location Name (RMTLOCNAME)" on page 2-28. In the System/38 environment, support exists to mask the use of the RMTLOCNAME parameter for certain functions. In the OS/400 program, you must specify a value. See "Distributed Data Management (DDM)" on page 4-6.

Return Codes: The return codes used by the System/38 file types CMNF and BSCF have changed significantly with the new ICF file.

An MXDF file must be converted to either or both an ICF or display type. An MXDF uses the return codes for the type of file used. The BSC and CMN types have changed significantly. The display types are the same as in the System/38 environment.

The return codes used by the other System/38 file types had some changes from System/38 to the System/38 environment. No changes are required from the System/38 environment to the AS/400 system. Return codes are further described in the following:

- Appendix C of this manual
- *Data Management Guide*
- *ICF Programmer's Guide*

Save Files: Other than the command changes described in Appendix A, no changes are needed from the System/38 environment.

Save and Restore: Changes to parameter defaults include:

- Volume ID (VOL) on restores from *SAVVOL to *MOUNTED.
- Clear data (CLEAR) from *NO to *NONE. New values are *ALL and *AFTER. *YES is deleted.

The diskette LOC parameter is deleted.

The device (DEV) parameter is required. *SAVF is now supported as a device name.

The FILEMBR parameter has been added to allow saving and restoring of selected members.

See Appendix A for details of parameter changes to the Save and Restore commands. A new command exists (SAVSTG) to save all of the used storage on the system. SAVSTG is designed to assist in a disaster recovery situation.

Screen Formatting: No changes from the System/38 environment.

Security

Authorization: The authorization to IBM commands does not change from the System/38 environment to the OS/400 environment. Although some command names have changed, the authorizations remain the same.

AUT Parameter: The PUBAUT parameter on CRT commands has changed to AUT and the defaults vary by command. The values become *CHANGE, *USE, or *EXCLUDE. The net result is identical with the CRT commands supplied for the System/38 environment. (See Chapter 2 for a further discussion.)

CHGOBJOWN default change: The CHGOBJOWN command supports a new parameter, CUROWNOUT. This defaults to revoke the owner's authority. System/38 did not support the parameter and retained the old owner's authority.

Service: Available in the OS/400 program only.

Session Description: Other than the command changes described in Appendix A, no changes are required from the System/38 environment.

Shipped Objects: No changes from the System/38 environment.

Sign-On: Available in the OS/400 program only.

SNADS: Other than the command changes described in Appendix A, no changes are required from the System/38 environment.

Source Attribute: See "Object Attributes and Source Types" on page 2-23.

Source Files: Other than the command changes described in Appendix A, no changes are required from the System/38 environment.

Spelling Dictionary: Other than the command changes described in Appendix A, no changes are required from the System/38 environment.

Spool

OVRPRTF parameters: New parameters that exist on the OVRPRTF command to help describe the spooled file include:

- SPLFNAME allows you to change the name of the spooled file. For example, assume you use the name QPRINT in your program. You can specify that the name should now be known as PAYROLL. This is desirable when you do not use externally described printer files. All further operations (such as WRKSPLF) must refer to the new name. The name of the original printer file can be displayed with WRKSPLFA.
- USRDTA allows you to specify text that is shown with the spooled file. Spool commands also allow selection on USRDTA. If a program is created on an AS/400 system, this parameter uses the name of the program that opened the spool file as the default.
- DUPLEX allows you to specify whether the spooled file will be printed on one side of the

page, on both sides of the page with the top of the page the same for both sides, or on both sides of the page with the images on both sides inverted.

Both the spooled file name and USRDTA appear on the first display of an output queue.

OVRPRTF file name: On System/38, if you specified:

```
OVRPRTF QPRINT TOFILE(XYZ)
```

the name of the spooled file on DSPOUTQ was XYZ. On the AS/400 system, the program name will be used. If you want to change the spooled file name, you should use the new SPLFNAME parameter.

Subsystem Description: Other than the command changes described in Appendix A, no changes are required from the System/38 environment.

System Reply List: Other than the command changes described in Appendix A, no changes are required from the System/38 environment.

System Request: No changes from the System/38 environment.

System Service Tools (SST): Available in the OS/400 program only.

System Values: The new system values can only be used by OS/400 commands. Additional information is provided in "System Values" on page 2-56.

Appendix A provides information about specific command changes.

Table: Other than the command changes described in Appendix A, no changes are required from the System/38 environment.

Tape: Other than the command changes described in Appendix A, no changes are required from the System/38 environment.

Test: See "Debug" on page 4-6.

Uninterruptible Power Supply: Available in the OS/400 program only. The *Backup and Recovery Guide* contains more information.

User Profile: See "Security" on page 4-14.

Work Management: When specifying work management functions within the System/38 environment, you must consider the following changes:

SBMJOB CMD parameter: SBMJOB allows either the new CMD parameter or the RQSDTA parameter. The CMD parameter should be used when you are submitting a command. A syntax check of the command is made before it is submitted. The prompter is available with F4 for submitting the command. Expressions are allowed within parameter values, but cannot be used to build the command name or parameter names.

SBMJOB USER parameter: SBMJOB allows the USER parameter to specify a user name in addition to the entry of *JOB or *CURRENT. You must have the *OBJOPR right to the user profile to use a specific name.

SUBMIT JOB defaults: SBMJOB defaults change as follows:

- JOBD(*USRPRF) instead of QBATCH. The *USRPRF entry means to use the JOBD parameter value specified in the user profile associated with the submitted job.
- INLLIBL(*CURRENT) instead of *JOB. This *CURRENT entry means to use the current library list instead of the library list in the job description. In general this is a preferred default, but some specific applications may have to be changed rather than using the default.
- OUTQ(*CURRENT) instead of *JOB. This means to use the current output queue assigned to the job instead of the value in the job description. This may cause any spooled output to be routed to a different output queue.
- RTGDTA(QCMDB) instead of *JOB. The System/38 environment command uses QCMD38 as the default. This change is needed to access the OS/400 routing step program (QCMD) for a batch program.

For those users operating with just the QBASE subsystem, this is an important default. If the default were *JOBDB, the USER parameter default is *CURRENT which normally results in using the interactive JOBDB to which the user is signed on. The RTGDTA value in a JOBDB defaults to QCMDI which would cause a batch job to be run with interactive characteristics (for example, in the interactive pool).

- RQSDTA defaults to *CMD instead of *JOBDB.
- The SBMJOB MSGQ default has been changed from *WRKSTN to *USRPRF.

Display and work commands: The DSPJOB function has been split into two commands. WRKJOB performs the identical function as the System/38 DSPJOB. The OS/400 DSPJOB command is a display-only function. Some commands offer an option list of jobs and may allow either DSPJOB or WRKJOB. You must be authorized to the appropriate command. The *Work Management Guide* has more information.

Job streams: See “Job Streams” on page 4-9.

Work Station: The new help information function is described in “Data Description Specifications (DDS)” on page 4-4.

X.25: Other than the command changes described in Appendix A, no changes are required from the System/38 environment.

Utilities and Other Program Products

All utilities are the same as in the System/38 environment except for those listed in this section. Command changes exist for some utilities and are described in Appendix A. See Chapter 2 for the enhancements made to the Reformat Utility (now the OS/400 Sort Utility).

Remote Job Entry (RJE):

- The READFILE command is only supported in the AS/400 system.
- DDM files are allowed for file names.
- Command changes are described in Appendix A.

Data File Utility (DFU): No function exists to assist you in converting from the System/38 DFU to the AS/400 DFU. You must reenter each DFU.

Several functions in the System/38 DFU do not exist in the AS/400 DFU. If you are considering a conversion, you may need to take these into account or continue to use the System/38 environment version. The following are some of the functions that are not included:

- Display-oriented design as opposed to record-oriented.
- User-specified display flow (chaining).
- Display-level design flexibility including such things as heading location, initial values, field spacing, edit codes, and multiple lines per screen.
- Validity-checking functions such as mandatory entry, mandatory fill, and relation operations.
- Batch creation.
- Retrieving source.
- Multiple commands (CRTDFUDEF and DSNDFUAPP). The CRTDFUDEF command was used in some applications after asking the end user for a valid file name. This allowed application control of security over the files to be operated on by DFU.
- Delete mode.
- Verify mode.
- Automatic numbering.
- Search on next format.

Query: No function exists to assist you in converting from the System/38 Query to the AS/400 Query. You must reenter each query.

The new AS/400 Query has several enhancements over the System/38 Query that you may want to take advantage of. These include such things as:

- The RUNQRY command allows a simple display of any database file without initially creating a query object. A prompt exists for selection specifications. A window function is also available, allowing for debugging and problem determination aid.

- A function can display either the layout of the report or the report while defining the query.
- Changes to the Query definition can be done in the same manner as it was defined.
- On-line help and information search capability.
- Collating sequence support.
- Text can be specified for report breaks.
- Additional numeric editing.
- Create character result field using substring and concatenation.

Several functions in the System/38 Query do not exist in AS/400 Query. If you are considering converting, you may need to take these into account. The following are some of the functions that are not included:

- Batch creation.
- Retrieving source.
- Multiple commands (CRTQRYDEF and DSNQRYAPP). The CRTQRYDEF command was used in some applications after asking the end user for a valid file name. This allowed application control of security over the files to be used by Query.
- Tables.
- Record sampling.
- Remainder function available for created result fields.
- *OMIT on record selection.
- Support of multiple format files.
- DDM Support (performing a Query on a file on another system).

Source Entry Utility (SEU): Enhancements for SEU include:

- More line commands including:
 - Exclude and show
 - Shift with truncation
 - Format line and prompt list
 - COLS and TABS
 - Copy and repeat
- Improved prompts, including user-defined prompts
- Improved service displays, line command processing, and member lists

Languages

Not all new functions in the languages are discussed here. See the individual publications describing each language. This section describes any source or command changes you need to consider from the same user programs running in the System/38 environment.

If your language allows and you make use of qualified names, you need to convert these to OS/400 syntax, such as the COBOL COPY statement or the RPG /COPY statement. Command changes and parameter differences exist which may affect programs. For command changes, see Appendix A for more specific information.

BASIC: Qualified object names must appear in OS/400 syntax.

COBOL: The System/38 COBOL level is ANSI 74. The AS/400 version is ANSI 85. The following differences exist:

- An index name is a compiler generated storage area that is 4 bytes in length.
- A temporary result field is generated by the compiler when only one identifier is specified in the following cases:
 - In the ADD statement FORMAT 1, preceding the keyword TO
 - In the SUBTRACT statement, FORMAT 1, preceding the keyword FROM
 - In the MULTIPLY and DIVIDE statements, FORMAT 1
- Card-specific language features are not supported.
- The keyword ALPHABET must precede alphabet-name within the alphabet-name clause of the SPECIAL-NAMES paragraph.
- The relative key data item specified in the RELATIVE KEY phrase must not contain the PICTURE symbol 'P'.
- The ALPHABETIC class test is true for uppercase letters, lowercase letters, and the space character.
- When no next statement exists to be processed in a called program, an implicit EXIT PROGRAM statement is run.
- No two files in a MERGE statement may be specified in the SAME AREA or SAME

SORT-MERGE AREA clause. The only files in a MERGE statement that can be specified in the SAME RECORD AREA clause are those associated with the GIVING phrase.

- READ statement: the INTO phrase cannot be specified: (a) unless all records associated with the file and the data item specified in the INTO phrase are group items or elementary alphanumeric items, or (b) unless only one record description is subordinate to the file description entry.
- RETURN statement: the INTO phrase cannot be specified: (a) unless all records associated with the file and the data item specified in the INTO phrase are group items or elementary alphanumeric items, or (b) unless only one record description is subordinate to the file description entry.
- File position indicator: the concept of a current record pointer has been changed to a file position indicator.
- New reserved words have been added.
- New I/O status values have been added.
- Pseudo-text-1 on the COPY statement must not consist entirely of a separator comma or a separator semicolon.
- Text word rules are followed for COPY REPLACING.
- A data item appearing in the USING phrase of the Procedure Division header must not have a REDEFINES clause in its data description entry.
- If the FOOTING phrase is not specified, no end-of-page condition independent of the page overflow condition exists.
- The NO REWIND phrase cannot be specified in a CLOSE statement having the REEL.UNIT phrase.
- The CANCEL statement closes all open files.
- When a receiving item is a variable length data item and contains the object of the DEPENDING ON phrase, the maximum length of the item is used.
- Within the VARYING ... AFTER phrase of the PERFORM statement, identifier-2 is augmented before identifier-5 is set.
- Any subscripts for identifier-4 in the DIVIDE statement REMAINDER phrase are evaluated

after the result of the DIVIDE operation is stored in identifier-3 of the GIVING phrase.

- The phrase ADVANCING PAGE and END-OF-PAGE must not both be in a single WRITE statement.
- The picture character-string of an alphabetic item can contain only the symbol 'A'. No editing is allowed for the alphabetic data category.
- When a data item described by a PICTURE containing the character 'P' is referred to, the digit positions specified by 'P' are considered to contain zeros in the following operations:
 - Any operation requiring a numeric sending operand.
 - A MOVE statement where the sending operand is numeric and its PICTURE character-string contains the symbol 'P'.
 - A MOVE statement where the sending operand is numeric edited and its PICTURE character-string contains the symbol 'P' and the receiving operand is numeric or numeric edited.
 - A comparison operation where both operands are numeric.
- Programs using ACCEPT FROM ATTRIBUTE-DATA require changes because format of data returned is different from System/38 COBOL.

PASCAL: Available in the OS/400 program only. System/38 PASCAL must be compiled on the AS/400 system.

PL/I: Other than the command changes described in Appendix A, no changes from the System/38 environment are required.

Report Program Generator (RPG): These are the differences between System/38 environment RPG and RPG/400:

- The INFDS layout has been enhanced to support additional I/O feedback for the POST operation.

Programs using the POST operation for a specific device (not to get I/O feedback) must change because the format of the information returned in the INFDS in RPG/400 has

changed from the format used in System/38 environment RPG.

- The maximum numeric field length has been increased from 15 to 30 digits.
- There is a change in source member type for Auto Report. See "Object Attributes and Source Types" on page 2-23.
- The compiler issues a warning message if the source member type is not what is expected. CRTRPGPGM expects type RPG and CRTRPTPGM expects type RPT.

- To convert using source and re-compilation, you must have all the source members that are used by a COPY statement.
- A new value (*SECLVL) may be specified on the OPTION keyword to allow for printing of the second level message text.
- New *STATUS values in the INFDS may require changes.

For more information, see Appendix E, "Converting RPG from System/38 to the AS/400 System," and the *RPG/400* User's Guide*.

Chapter 5. Coexistence with an AS/400 System

You may have a need to send data from a System/38 to an AS/400 system or vice versa. You may want to exchange media or be tied together through a communications line. This chapter covers:

- How media can be interchanged between System/38 and the AS/400 system
- What you should do if you have a System/38 that is communicating to other systems, and you replace your System/38 with an AS/400 system
- What the other systems you are communicating with have to do when you replace a System/38 with an AS/400 system

Interchanging Media

The OS/400 object form differs from the System/38 object form. Consequently, you cannot save an object from an AS/400 system and restore it on a System/38. A save from System/38 can be restored on the AS/400 system and the information is mapped into the AS/400 format. However, data interchange is supported in either direction. You must have compatible media (for example, 1/2-inch tape, recorded at the proper density) supported on both systems. The following describes the interchange between the two systems:

System/38		AS/400 System
Save	→	Restore
Data interchange	→	Copy
Not supported	←	Save
Copy	←	Data interchange

If your requirement is only to interchange from System/38 to an AS/400 system, you can use either the save and restore format or data interchange. If you want to go from an AS/400 system to System/38, you can only use data interchange. You must have compatible media (for example 1/2-inch tape) and density on both systems.

If you are interchanging data between a System/38 and some other system type (for example, System/370) and replace the System/38 with an AS/400 system, the data interchange format can continue to be used. You

must have compatible media and density supported on both systems. No changes are necessary in the data interchange format.

Interchanging Save File Data

Save file data is considered to be restorable. When data is written to a save file, it is checked to ensure it is restorable on the system. Therefore, the rules are similar to save and restore:

- System/38 save file data can be written to a save file on either a System/38 or an AS/400 system.
- AS/400 save file data can be written to a save file on another AS/400 system.
- AS/400 save file data cannot be written to a System/38 save file.

Exchange ID

The Exchange ID is used when the system is in an SNA session (such as 5250 Pass-Through, object distribution, LU-0, and DDM). The System/38 ID prefix is 022. The prefix has changed with the AS/400 system because it is a new system type. The new prefix is 056.

On System/38, the line description EXCHID parameter can be either *NONE or a specific value.

- If *NONE is used, the system creates a line description ID which is the 3-digit prefix followed by the system serial number. The value that is used can be displayed by DSPLIND. If you are migrating your System/38 line description object with *NONE as the original value, the Migration Aid changes the prefix of the ID to 056 and uses the serial number from the System/38. Therefore, your system has a different exchange ID.

Note: The serial number does not reflect the new AS/400 system.

- If a specific value is described, the first 3 characters must be the system prefix. If you migrate the line description object to the AS/400 system, the prefix is changed by the

Migration Aid to 056. Therefore, your system has a different exchange ID.

The system you are communicating with (assuming you are using the EXCHID feature) needs to be changed to agree with the new AS/400 exchange ID. You may wish to change the ID before you start communications to reflect your own specific value or to use the serial number of the AS/400 system assigned by the default value. If you migrated the device configuration objects using the Migration Aid, you must delete and re-create the line description object (the EXCHID parameter cannot be changed by the CHG command).

If the system you are communicating with is a System/38 or another AS/400 system, the EXCHID you need to change on that system is specified on the controller description. You need to delete and re-create the controller description object on the System/38 or AS/400 systems you are communicating to (the EXCHID cannot be changed using the CHG command).

APPC

No changes are needed for APPC other than the exchange ID.

Pass-Through

The exchange ID must be changed as described.

If a user is passing through to a System/38 and it is replaced by an AS/400 system, the user must enter the proper syntax if commands are used and will see some operational differences.

Object Distribution

The SNDNETF, SNDNETMSG, and SNDNETSPLF commands can be used to go in either direction between System/38 and the AS/400 system. However, only System/38 existing attributes can be exchanged using SNDNETSPLF to a System/38. See the example in Chapter 6 for how you can distribute System/38 objects using OS/400 object distribution.

If you use the SBMNETJOB command to an AS/400 system, you must supply AS/400 syntax for the commands in the input stream.

New support exists to send messages, files, and job streams to a System/370. See the *Distribution Services Network Guide* and "SNADS" also.

SNADS

If you are communicating to a System/370 and using the new support for the RSCS/PROFS* bridge, the System/370 must have installed the RSCS Version 1.3 or later and the VM Line Driver PRPQ.

Interchanging Using Communication or Mixed Files

On an AS/400 system, the SECURITY keyword in DDS does not support the *PASSWORD function, meaning that the AS/400 support does not retrieve the password to send to the other system. Files with the *PASSWORD function cannot be restored or created on the AS/400 system. If you are currently using this technique, you must make a change that could also affect the systems you are communicating with. You must either code the password value or configure your system so that a password is not required with the EVOKE function.

Interchanging Using DDM

Source system: If a System/38 is replaced with an AS/400 system and it is the source system for DDM requests, no changes are needed. The DDM files continue to correctly specify the files to be accessed in the appropriate syntax of the target system.

Target system: If a System/38 is replaced with an AS/400 system and it is the target system for DDM requests, the source systems communicating to the new AS/400 system may have to change. The source systems must specify the syntax of the AS/400 target system, regardless of whether the file being accessed on an AS/400 system is a System/38 or OS/400 type file. If the source system is a System/38 or an AS/400 system, the RMTFILE value of the DDM files must be reviewed (the equivalent value must be reviewed for a non-System/38 and non-AS/400

system). The DSPFD command can be used to display the RMTFILE value on System/38 or the AS/400 system. The AS/400 system can also use DSPDDMF or WRKDDMF to display RMTFILE values.

- If you specified the entry as RMTFILE(FILEX), the default is no library name and the value *FILEX* is passed to the other system. On the System/38 or the AS/400 system, this is interpreted as FILEX using the library list of the target job (the target job's library list is defined by the job description specified on the ADDCMNE command). In this case, no change is needed. (The job description could use the user profile or initial library list associated with the job.)
- If a qualified name was used, such as FILEX.LIBY or FILEX.*LIBL, the new syntax of LIBY/FILEX or *LIBL/FILEX must be used.

Note: The syntax of the RMTFILE parameter differs from most qualified names in that no library default of *LIBL is supported. The default for RMTFILE is no library qualifier. If you took the default, you do not need to make a change.

RMTFILE: If you need to specify a qualified name, you may have to use the *NONSTD entry on the RMTFILE parameter:

- In the OS/400 program, the remote file name for another AS/400 system would be specified as:

```
RMTFILE(LIBY/FILEX)
```

- In the OS/400 program, the remote file name for a System/38 would be specified as:

```
RMTFILE(*NONSTD 'FILEX.LIBY')
```

- On a System/38, the remote file name for an AS/400 system would be specified as:

```
RMTFILE(*NONSTD 'LIBY/FILEX')
```

- If you are on an AS/400 system in the System/38 environment, the remote file name for System/38 is:

```
RMTFILE(FILEX.LIBY)
```

- If you are on an AS/400 system in the System/38 environment, the remote file name for an AS/400 system is:

```
RMTFILE(*NONSTD 'LIBY/FILEX')
```

When a DDM file is displayed (DSPDDMF command) the file name is shown within apostrophes such as:

```
RMTFILE 'ABC.DEF'
```

This is the way the information is stored within the system. If migration of a DDM object occurs to an AS/400 system, no change is needed to communicate as a source system to a System/38.

The following illustration describes the source and target system considerations.

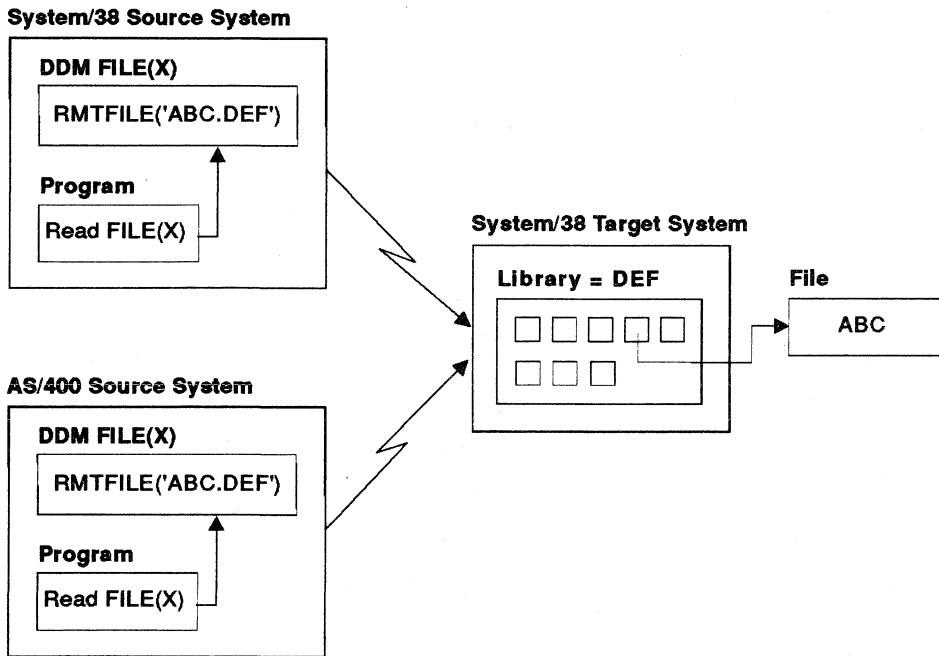

RV2W326-0

Because the target system is a System/38, both source systems use the same specification for RMTFILE. If the source System/38 is replaced by an AS/400 system, no changes are needed for the DDM file. If, however, you create a new

DDM file on the AS/400 source system to communicate to the System/38 and need a qualified name, you would specify:

```
RMTFILE(*NONSTD 'OBJ.LIB')
```

The following shows a System/38 target system replaced by an AS/400 system.

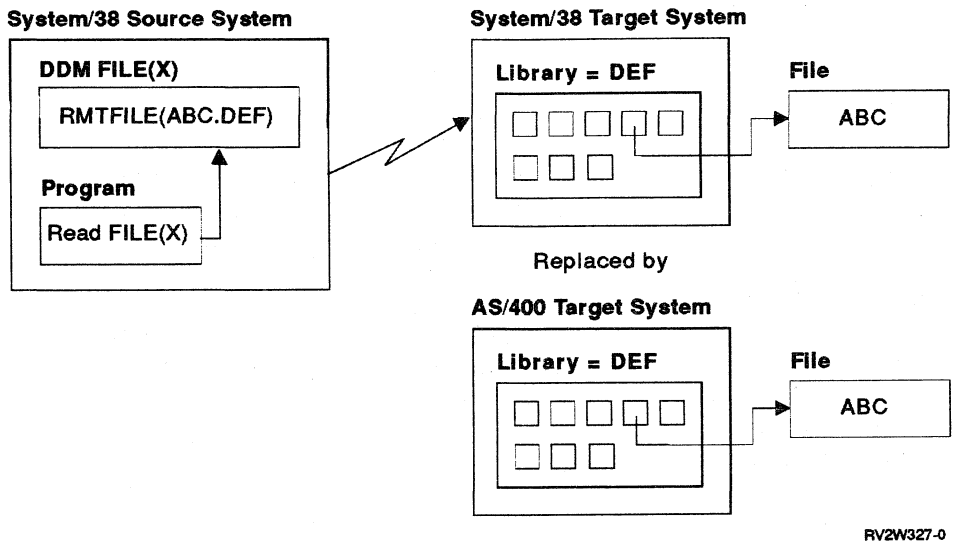

RV2W327-0

The target System/38 is replaced by an AS/400 system. The RMTFILE parameter must now be changed on the source system to agree with the OS/400 syntax. On the source System/38, you would specify:

```
RMTFILE(*NONSTD 'DEF/ABC')
```

Note: The syntax for an unqualified name is the same regardless of System/38 and System/38 source target combinations. It would be specified as:

```
RMTFILE(FILEX)
```

Any use of a SBMRMTCMD to an AS/400 system must supply OS/400 syntax.

Any System/38s that use DDM to communicate to an AS/400 system must have a compatibility PC applied. This allows System/38 DDM architecture extensions to be sent and received.

Alerts

The AS/400 system uses the SNA management services generic alerts. The System/370 host system must have at least Release 2.0 of NetView installed.

If a System/38 sends a pre-generic NMVT alert to an AS/400 system, it is accepted and can be displayed.

On System/38, alerts were logged to a journal (QALERT). This has been changed to a database file on the AS/400 system. The journal is not migrated. A new display command exists to display the alerts.

The ADD/CHGMSGD commands have parameter changes, as described in Appendix A.

Interchanging PC Data

PC data on the AS/400 system is stored in the new folder object type. No support is available to extract the information from a folder and convert it to a virtual disk for use on a System/38. A command (CPYFRMPCD) does exist on the AS/400 system to copy a document in a folder to a database file, but the internal format of this file is not the same as that used for System/38 virtual disk.

PC Support/400 also supports the CVTTOFLR command. This allows you to convert files from System/38 to AS/400 folders. This may be used solely for migration or on a continuing basis.

The following describes the interchange between the two systems:

System/38		AS/400 System
Virtual disk	→	Folder (using CVTTOFLR)
Not supported to virtual disk	←	Folder

Interchanging Journal Objects

Journal objects (journals and journal receivers) can be moved from System/38 to the AS/400 system using save and restore. The journal restrictions that exist on System/38 for moving journal objects to a different system are the same for moving journal objects to an AS/400 system.

Objects (including journal objects) cannot be saved from an AS/400 system and restored to a System/38.

The DSPJRN command output file format is identical between System/38 and the AS/400 system. Therefore, it is valid to have a user-written cross

system journaling application using an AS/400 system and a System/38.

However, because restore is not supported from an AS/400 system to a System/38, you cannot initialize (replace or add a new file) on the System/38 using a save from the AS/400 system. If you need to replace or add a new file, you can only use data interchange. Using CPYF for data interchange does not necessarily cause a mirror image of the data because the relative record numbers are reset.

If your user-written journal apply program is dependent on relative record numbers, you need to ensure the deleted records are compressed from the file (using RGZPFM) before you copy it to the System/38.

Chapter 6. Maintaining System/38 Applications on an AS/400 System

For some businesses, you may need to operate on an AS/400 system and maintain applications that are being used on a System/38. This would be typical if:

- You have both systems for a period of time.
- You are a central site maintaining a network of systems.
- You sell software to both AS/400 and System/38 users.

It is feasible in most cases to maintain the System/38 application code on the AS/400 system and perform source maintenance and most testing on the AS/400 system. You can only test certain functions that are not supported on the AS/400 system (for example, configuration commands) on an actual System/38.

If you are planning to use the same application on the AS/400 system as on System/38, you need a strategy for how you will do source maintenance. For example, you could plan on maintaining only one set of source for both systems. While this is clearly desirable, it may not be achievable due to migration changes or the desire to use new AS/400 function. Obviously, any additions to your applications of new AS/400 function cannot be used on System/38.

Maintaining System/38 source can be easily achieved using the Programmer Menu or the programming development manager on the

AS/400 system. You need to specify the System/38 types of source (see Chapter 1). After you have tested the program on the AS/400 system, you need to move the source to a System/38. You cannot save an object from the AS/400 system and restore it to a System/38. Only data interchange can be used. The following describes the interchange between the two systems:

System/38		AS/400 System
Save	→	Restore
Data interchange	→	Copy
Not supported	←	Save
Copy	←	Data interchange

Data interchange could be in the form of media, DDM, or communication files. Once the source is on the System/38, you can create the object and perform final testing. Either the object or source form can now be distributed to other System/38s in save and restore format.

The object distribution commands (SNDNETF, SNDNETMSG, and SNDNETSPLF) can be used in either direction between the AS/400 system and System/38. However, only System/38 existing attributes can be exchanged using SNDNETSPLF.

Another alternative is to have source on both systems and maintain the System/38 source by using a function like display station pass-through.

It is also possible to use the object distribution function of the AS/400 system to distribute

objects to other System/38s. You would typically do the following:

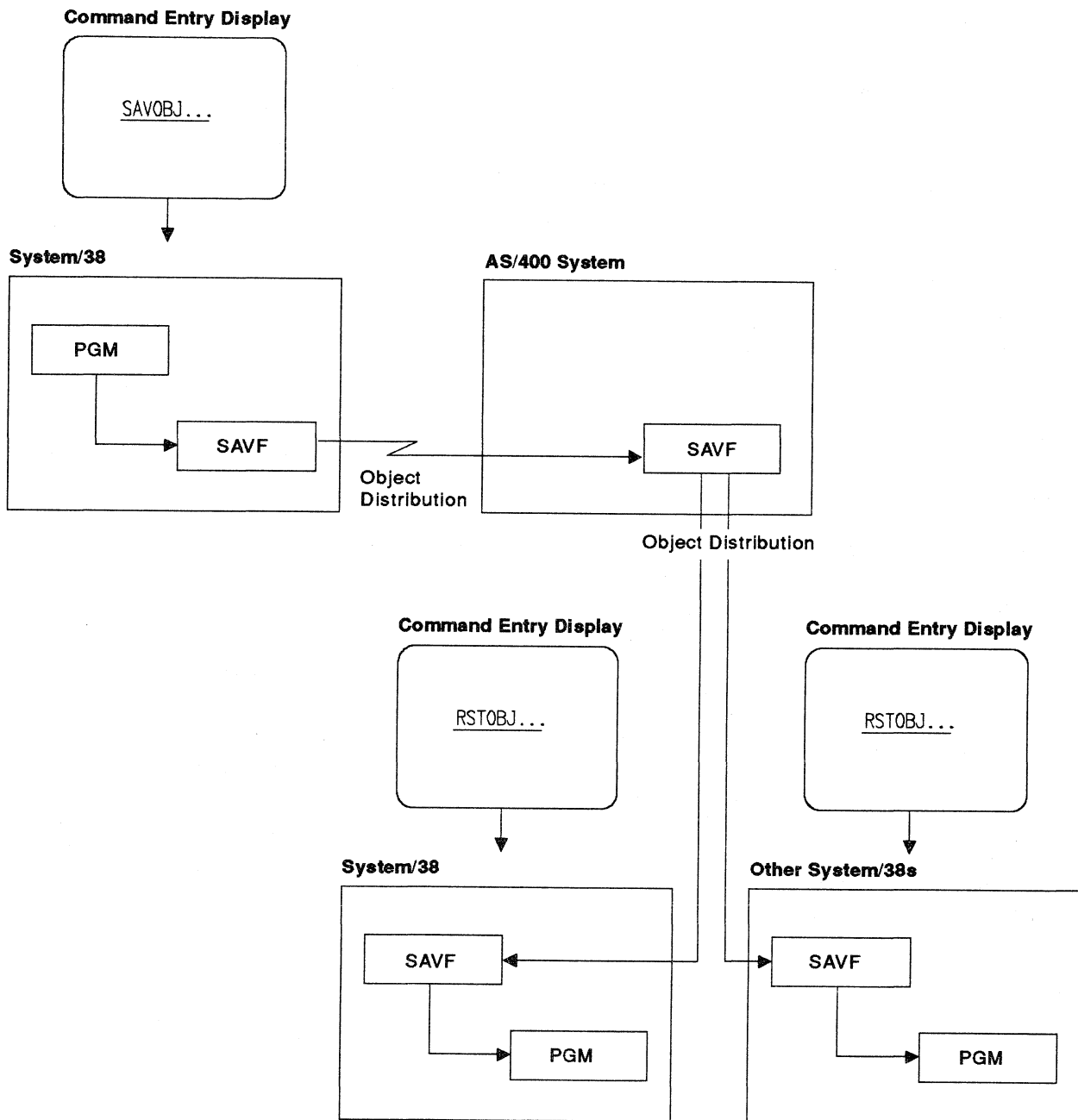

RV2W328-0

The SAVOBJ command is used on a System/38 to place a program into a save file. The file is sent to an AS/400 system using object distribution. The save file on the OS/400 program is then sent to multiple System/38 systems also using object distribution. The RSTOBJ command is then used to make a program object on each System/38.

Note: Object distribution on the AS/400 system is being used, but only to pass the System/38 object form to another System/38. The System/38 object could be restored to an AS/400 system, but normally this is not needed once you have migrated.

See “Interchanging Save File Data” on page 5-1 for a discussion of save file restrictions.

Pass-Through is a good method of operating on an AS/400 system and working with a System/38. You may want the same programmer to perform the preliminary testing on the AS/400 system and complete the testing on System/38. Pass-Through allows programmers to sign on the System/38 while they are still signed on the AS/400 system.

The System/38 environment support allows you to enter certain commands using SEU, which cannot be run on the AS/400 system. For example, the CRTDEVD command can be entered in SEU using type CLP38 and the program creates successfully. However, if you try to use the command on the AS/400 system (even in the System/38 environment), the CRTDEVD command fails with an error message. The purpose of this support is to assist in maintaining source on the AS/400 system that you intend to use on System/38.

The commands that only exist in the System/38 environment for this purpose (they cannot be run) are described in Appendix A.

If you are migrating to the AS/400 system with the intent of maintaining applications for System/38, you may need to make some changes to the applications to get them to successfully migrate. If you have changed the source during migration, you may need to work with multiple versions of the same source.

The CVTCLSRC command can be used to convert System/38 CL source into OS/400 source. However, the inverse is not supported

(if you have OS/400 CL source, you would need to do a manual conversion to change it to System/38 source).

Other considerations with different OS/400 functions to be considered with coexistence are:

- You need some method of shipping job streams for those functions that are maintained by commands (for example, changes to job descriptions).
- The OS/400 DFU and Query functions cannot be sent to System/38. The System/38 environment DFU and Query source can be extracted using the RTVxxxSRC commands and sent to a System/38.
- Chapter 1 describes how a CLP38 type program can contain OS/400 commands. For example, you could use the OS/400 command WRKOUTQ in the CLP38 program, but you must enter it using System/38 syntax rules. You do not want to distribute this source to a System/38. You could write a program that checks your source to ensure it contains only System/38 commands. An example of this type of program is included in the QUSRTOOL library. See the tool CHKS38CMD.

Automating Most of the Process

Typically, you want to maintain the source on the AS/400 system, do some degree of testing on the AS/400 system, and then automate as much as you can of the remaining process. This would include sending the source to a System/38 (or using DDM for the source file), creating the objects, performing final testing, integrating the new objects into a production system, and possibly distributing object form to other System/38s.

Once you decide what source and data files need to be sent to maintain the application, you want some packaging method of placing the data into a convenient container to ship to a System/38 (assuming you are not using a DDM source file).

For example, you could write a user command that allows multiple source members and data files to be copied to a single member. The single member could then be sent to the

System/38 using object distribution, DDM, a communications file, or media (diskette or tape).

When the data is placed on the System/38, a similar user-written command could extract the pieces and put them back into their original file and member names on the System/38. An example of this type of command is included in the QUSRTOOL library. See the tool SAVICHDTA.

A user written function could then schedule the CRT commands necessary to create the object forms required. Another alternative is to send a request for a compile to the System/38 and use a DDM file on the System/38 to access the source on the AS/400 system. After the objects are created, pass-through could be used to ensure a final degree of testing on System/38. When the objects are ready, you could then have a user-written command on the System/38 which saves the objects and prepares them for distribution to other System/38s.

List by Function

The following list by function describes some of the typical things you need to exclude from source that you are trying to use on both the AS/400 system and System/38. Obviously, any new OS/400 commands, parameters, or values cannot be specified. Commands and command definition statement differences are discussed in Appendix A. DDS keywords are discussed in Appendix B.

APF

Although the System/38 APF files are compatible with the AS/400 system, you should not attempt to move the AS/400 APF files back to a System/38.

CL

The new qualified name syntax and the use of extended names is valid only on the AS/400 system.

CL Programs

New commands, parameters, and values are valid only in the OS/400 program. See Appendix A.

Command Definition

The new keyword PMTCTL on the PARM statement is valid only on the AS/400 system.

Note: It is valid to enter these new functions in the System/38 environment, but if you do, you will not be able to use the same command definition source on a System/38.

Commitment Control

The number of record locks supported is 4096 on the AS/400 system and 1024 on System/38.

Data Description Specifications (DDS)

ICF files are valid on the AS/400 system only.

See Appendix B for a list of DDS keywords that are not supported or are changed on the AS/400 system.

Database

The OPNQRYF command supports both qualified file and field names. Both must be in the proper syntax.

The new OS/400 OPNQRYF %DIGITS function for converting decimal data to character can only be done on the AS/400 system. The System/38 solution of converting first to zoned and then to character data is compatible between both systems.

Message Handling

The user message queue support on the AS/400 system can be partially achieved on System/38 with a user created queue and specific send message commands.

The increased size of the second level text and the special formatting characters are only supported on the AS/400 system.

Programs

If you are writing programs to be used on System/38, you want to ensure the use of functions like QCAEXEC instead of QCMDXC. If you are building up command strings in QCAEXEC, they should use System/38 syntax.

See "Return Codes" on page 6-5.

Return Codes

Changes exist between System/38, the System/38 environment, and the OS/400 program. See "Return Codes" on page 2-35 and "Return Codes" on page 4-13.

Languages

The new qualified name syntax is valid on the AS/400 system only.

COBOL

The ANSI level has changed and introduced new language elements. Conversion differences are described in Chapter 4. If you plan to share source, you may want to restrict your use to the ANSI 74 level.

Report Program Generator (RPG)

The use of 30-digit fields is an RPG/400 function only. Changes exist to STATUS values and the structure of INFDS for POST operations. If you plan to share source, you may want to restrict your RPG use to the System/38-compatible RPG.

Chapter 7. Summary of Migration Details

This chapter provides you with a summary of the following:

- What you should do on System/38 before you migrate
- What you should do on the AS/400 system before you migrate System/38 objects to the AS/400 system
- What you should do after you migrate the System/38 objects

What You Should Do on System/38 before You Migrate

Several things should be done on System/38 before you migrate.

Save and restore restriction: Only objects saved on System/38 Release 5 or later can be restored on the AS/400 system. If you have any historical information that was saved on previous releases that you may want to restore on the AS/400 system, you should restore it to the System/38 and save it again.

Any media you save to restore on the AS/400 system should be compatible in type and density to match your save and restore device on the AS/400 system. For example, the only compatible density for the 9347 Tape Unit is 1600 bpi.

Object descriptions for queues and save files:

The Migration Aid migrates the object descriptions for job queues, output queues, data queues, and save files. However, none of the data in these objects is migrated. You should ensure that these objects do not contain any critical data before migration.

Network attributes: Network attributes are not migrated. You must manually reenter them on the AS/400 system. Use the DSPNETA command and get printed output of the values or write them down. See the discussion in Chapter 2 of what network attributes have been deleted or changed.

System reply list: The system reply list entries are not migrated by the Migration Aid. You should use:

```
DSPRPLY OUTPUT(*LIST)
```

and save the printed output or write down the values. The IBM-shipped values with the AS/400 system have not changed from the System/38 shipped values. However, you may have made changes.

System values: Certain system values are not migrated by the Migration Aid. See "System Values" on page 2-56. You should print or write down the values for the following system values to assist in re-establishing them on the AS/400 system:

```
QACGLVL
QCTLSBSD
QUPSMGQ
QSYSLIBL
QMAXSIGN
QAUXSTGTH
```

Job accounting: If you are using job accounting, you should either re-create the QACGJRN journal in QSYS on the AS/400 system or save the object and restore it on the AS/400 system. The job accounting journal is not migrated by the Migration Aid.

QSYSMSG message queue: If you are using the QSYSMSG message queue function, you should save the message queue on System/38 and restore it on the AS/400 system. The message queue is not saved as part of the Migration Aid.

QSYS library: You should normally not place user objects in the QSYS library. If you have, they are migrated by the Migration Aid. A sample command (CHKLIBOWN) in Appendix D shows how to check for non-IBM owned objects in QSYS.

Licensed program libraries: If you have your own objects or members in a library such as QRPGLIB, you must either move them to a user library or migrate them using save and restore. Most licensed program libraries have an IBM-supplied source file that you could use to store members.

- You should use the following type of command to check each of the licensed program libraries to see if you have any

source members stored in an IBM-supplied file:

```
DSPFD QRPGRSRC.QRPG TYPE(*MBRLIST)
```

- You can use the sample command (CHKLIBOWN) in Appendix D to check for non-IBM owned objects in the licensed program libraries. Normally, the IBM objects are owned by QSECOFR. Therefore you should specify the command as:

```
CHKLIBOWN LIB(QRPG) EXCLUDE(QSECOFR)
```

If you created objects in the licensed program libraries owned by QSECOFR, you should find them using the DSPLIB command.

QGPL library: The QGPL library from System/38 should not be restored directly to the AS/400 system because it will overlay the IBM-supplied objects you need to operate the AS/400 system. The Migration Aid saves QGPL and restores it to QGPL38. (See the discussion on "Handling QGPL" on page 7-5.) If you are not using the Migration Aid, you should consider a similar approach.

Some objects (for example, journal and journal receivers) cannot be restored to a different library. Therefore, if you have journals and journal receivers in QGPL, you should save them and restore them directly to QGPL on the AS/400 system.

Other Q libraries: The Migration Aid does not migrate libraries which begin with Q except for the QGPL library. If you created libraries beginning with Q, you must migrate them using save and restore.

User libraries: If you are migrating all objects in a library, you should first review the contents and delete any objects that you will not need on the AS/400 system.

The Migration Aid saves your objects and restores them on the AS/400 system. Because media is involved, you may want to be sure you have adequate backup of the objects to be migrated. This is of particular importance if you are transferring the same storage units from System/38 to the AS/400 system. An additional save of the objects you are planning to migrate would be a reasonable approach.

Device configuration objects: If you plan to use the Migration Aid to migrate the device configuration objects, you must be using Release 8.

The device configuration objects are migrated from System/38 to the AS/400 system using the Migration Aid. However, it would be reasonable to keep the information about your device configuration before you migrate. Appendix D has a sample program that copies the configuration information into a source member. The member would then be saved by the migration function. The member could then be used on the AS/400 system, through SEU, if problems occur.

User profiles: The IBM user profiles (such as QSECOFR) are not migrated nor are any of the specific authorizations. The new AS/400 user profiles are used as a base and you must make modifications to them. Therefore, if you have made changes to the IBM user profiles, you should make a printed output of these so that you can change the corresponding user profiles on the AS/400 system.

Use the DSPUSRPRF command on System/38 with the OUTPUT(*LIST) function for the following user profiles:

```
QPGMR
QSYSOPR
QSECOFR
QUSER
```

The QPSR and QCE profiles are replaced on the AS/400 system by the QSRV and QSRVBAS profiles. Different functions are performed by the new user profiles so you must reevaluate your use of these user profiles as opposed to copying the QCE and QPSR information.

Edit descriptions: Edit description objects in QSYS are not migrated by the Migration Aid. The same defaults that were used on System/38 are used on the AS/400 system, but you may have modified some of the values. If you have modified any edit descriptions, you should use the DSPEDTD command for each of the modified descriptions.

SNADS: If you are using SNADS, the Migration Aid does not migrate the SNADS objects. You must reenter the SNADS configuration on the AS/400 system. You should not attempt to save the SNADS objects in QUSRSYS on System/38

as the format has changed on the AS/400 system.

You should make printed output of the SNADS configuration on System/38 using:

```
DSPDSTSRV OUTPUT(*LIST)
```

A change is required on the AS/400 system for remote location name, as described in "SNADS" on page 2-47.

Before Restoring the System/38 Objects

Two methods of ordering an AS/400 system are available and you need to complete this step differently depending on the method you select.

1. Total System Package

This is a convenient method of ordering both the hardware and software items. The system arrives with the software loaded, though it will be configured for a System/36 operation. For example, the QDEVNAMING system value will contain the value *S36 instead of the default (*NORMAL). Therefore, if you use this approach you will normally want to perform the following steps before you restore any objects saved from System/38.

These steps assume that you want to operate using the OS/400 program and the System/38 environment. If you want to use the System/36 environment, consult the *System Reference for the System/36 Environment* and you should decide how to specify the system values discussed in this section.

Sign on as the security officer.

- Change the QSPCENV system value from *S36 to *NONE. This causes any user profiles that are added to operate using OS/400 functions:

```
CHGSYSVAL  SYSVAL(QSPCENV) VALUE(*NONE)
```

- Change the QDEVNAMING system value from *S36 to *NORMAL. This avoids the use of the System/36 naming convention for device configuration objects:

```
CHGSYSVAL  SYSVAL(QDEVNAMING)
            VALUE(*NORMAL)
```

- Delete the programs that are associated with the System/36 environment. This saves a considerable amount of disk space:

```
DLTLICPGM LICPGM(5738SS1) OPTION (5)
DLTLICPGM LICPGM(5738RG1) OPTION (1)
DLTLICPGM LICPGM(5738CB1) OPTION (1)
```

All other system values are shipped with the defaults as described in the *CL Programmer's Guide*. You may want to review the device descriptions that exist on the system. These are named using System/36 naming conventions. You may choose to delete and re-create these.

2. Customized system

A customized system was the form followed by System/38. You order hardware and software and they arrive from different distribution locations. The licensed internal code is already loaded on your system. If you ordered the OS/400 program, it is also loaded on your system. Follow the installation instructions and install each of the licensed programs you have ordered. See the *Licensed Programs and New Release Installation Guide*.

All system values are shipped with the defaults described in the *CL Programmer's Guide*.

System values: Several system values should be set before you perform the restores as part of the Migration Aid. See the details discussed in "System Values" on page 2-56 and also the *Work Management Guide*.

- QSECURITY. This is the security setting on the system; the default is level 10. Level 30 is similar to the System/38 level of security. To change to level 30 issue the following command:

```
CHGSYSVAL  SYSVAL(QSECURITY) VALUE('30')
```
- QCTLSBSD. This system value is not migrated by the Migration Aid. Therefore, you may change it now to reflect your controlling subsystem strategy. The AS/400 default for QCTLSBSD is QBASE. This means that a single subsystem is used for interactive and batch work. You may want to use the QINTER, QBATCH, QCTL subsystem approach. See "Subsystem Description" on

page 2-52. To change to this approach use the following command:

```
CHGSYSVAL      SYSVAL(QCTLBSBD)
                VALUE('QCTL      QSYS')
```

- **QAUTOCFG.** This determines if local devices should be configured automatically. See “Device Configuration” on page 2-7. To change from the default of 1 (meaning the system should do automatic configuration) to user-controlled configuration, specify:

```
CHGSYSVAL      SYSVAL(QAUTOCFG) VALUE('0')
```

- **QPRTDEV.** This is the print device to be used with default spooling, as described in “Spool” on page 2-48. You would normally enter the name of your system printer. It is important that this value reflect one of your printers.

```
CHGSYSVAL      SYSVAL(QPRTDEV) VALUE(xxxxxx)
```

- **QSTRUPPGM.** This is the startup program described in “Subsystem Description” on page 2-52. You should consider your strategy for use of an automatic start job.
- **QPFRAJ.** This determines if the system should do performance adjustment for main storage pools and activity levels. See “Subsystem Description” on page 2-52. You should consider your strategy for this function.
- **QSYSLIBL.** Use the information you printed from System/38 to establish this value. The AS/400 system requires:

```
QSYS
QHLPSYS
QUSRSYS
```

If you have additional libraries, you should change QSYSLIBL.

```
CHGSYSVAL SYSVAL(QSYSLIBL) VALUE('...')
```

- **QMAXSIGN.** This value now controls the number of sign-on attempts for all work stations (including the IPL device). Use the information from System/38 to establish this value:

```
CHGSYSVAL SYSVAL(QMAXSIGN) VALUE('...')
```

- You may want to set other system values. However, you should not set the system values that existed on System/38 because many of them will be overlaid when you perform the migration function.

System reply list: You should check the current System Reply List against the version you printed in the step before migration. The IBM-shipped versions have not changed from System/38 (PL/I has been added), but you may have made changes that need to be reflected on the AS/400 system.

Job accounting: If you were using job accounting on System/38, you should now re-create or restore the accounting journal (QACGJRN in QSYS) you saved from System/38. The Migration Aid migrates the QACGLVL system value. However, if the QACGJRN journal is not on the AS/400 system when the Migration Aid is run, the system value is set to *NONE.

QSYSMSG message queue: If you were using the QSYSMSG message queue on System/38, you should now restore the object you saved from System/38.

IPL: When the first IPL of the system occurs, the system implicitly creates a work station controller and display device to be used for the console. These will be named:

```
QCTL          WS controller
QCONSOLE      Display device only
```

You may delete these descriptions, but the system always creates a description using these names on the next IPL.

QAUXSTGTH: The System/38 QAUXSTGTH system value is not migrated by the Migration Aid. On the System/38, this system value determines when you will receive a message from the system based on the auxiliary storage use. You wrote down the QAUXSTGTH value in the step before you migrated. If the value is other than 10% or you want a value other than 10%, you need to use SST to set the new value. The specification has changed from a *percentage remaining* to a *percentage full*. The default is 90%.

Checksums and auxiliary storage pools (ASP): If you are using checksums or ASPs, you should specify the configuration desired with Dedicated Service Tools (DST).

Save the system: If you have not already done so as part of the installation process, save the AS/400 system with the SAVSYS command before migrating the System/38 objects.

Migration of System/38 Objects

This is normally done as part of the Migration Aid. Complete the steps as described with the Migration Aid including such functions as the restoring of profiles, device configuration objects, and other objects.

The Migration Aid restores QGPL to QGPL38. Before you run the RSTAUT command you should move your user objects from QGPL38 to QGPL. See the discussion in "Handling QGPL."

When migration is complete, your objects are restored to the system. Some objects may not be correctly restored. You need to check the results of the Migration Aid.

Handling QGPL

The IBM-supplied objects in QGPL on System/38 should not be restored on top of the AS/400 objects of similar names. The Migration Aid restores QGPL to QGPL38.

Some objects (for example, journal and journal receivers) cannot be restored to a different library. If you had saved these in the steps prior to migration, you should now restore these to QGPL.

On the AS/400 system you need to move user-created objects (those that do not begin with Q) from QGPL38 to QGPL. The following could be done:

- MOV OBJ commands could be issued.
- The new programming development manager could be used to simplify the keying of the MOV OBJ commands.
- A program could be used to do the MOV OBJ commands. A sample program is shown in Appendix D.

After your user objects have been moved from QGPL38 to QGPL, see *System/38 to AS/400 Migration Aid User's Guide and Reference* for specific instructions on restoring authorities to the object.

See also the discussion on "QGPL38."

What Should You Do after Migration

System values: Migration of System/38 objects resets the QMCHPOOL and QBASACTLVL system values and creates device configuration objects. The two system values may not be appropriate for your AS/400 system. You should now set the two system values. If you are using the IPL performance adjustment function, you can do another IPL and let the system set the values. You may have to reset the QACGLVL system value if the QACGJRN was not on the AS/400 system when the Migration Aid migrated system values.

User profiles: The printed output of the user profiles for QSECOFR, QPGMR, and QSYSOPR (see "What You Should Do on System/38 before You Migrate" on page 7-1) should now be reviewed with the AS/400 profiles to see if you need to change the profiles.

QGPL38: You need to consider the objects that remain in QGPL38 (those that begin with Q). These include such things as subsystem descriptions and job descriptions that were used by CPF on the System/38.

The following describes the items you should look for in QGPL38 and what you should consider. As each object is considered, you should either delete the object or move it to another library (for example, you could create QGPL38OLD). Moving the object to another library allows you to keep the information until you are sure you are operating correctly on the AS/400 system.

In this step, you also need to consider whether you had changed the IBM-shipped objects on System/38. You may need to compare the attributes of each object to the description in Appendix A of the *Release 8 IBM System/38 Control Program Facility Programmer's Guide*.

If you have made significant changes to the IBM-shipped objects (for example, subsystem descriptions), it may be easier to change your object than to change the AS/400 shipped version.

- The following objects are not restored on the AS/400 system because they specify unsupported functions:

```
QCARD96      *FILE
QCRDSRC      *FILE
QPUNCH       *FILE
```

- You may delete the following objects in QGPL38 because they are not needed on the AS/400 system:

```
QSPLCRDR     *JOB
QSPLCRDW     *JOB
QPUNCH       *OUTQ
```

- The source files in QGPL38 may contain data. If so, you will want to keep the data by moving or copying the members to the QGPL library. For example, you can check the following source files in QGPL and, assuming no members exist, delete them. Then move the objects of the same names from QGPL38 to QGPL.

```
QCLSRC       *FILE
QCMDSRC      *FILE
QTBLSRC      *FILE
```

The QDDSSRC file in QGPL will contain the source for the new QDSIGNON display on the AS/400 system. This should not be replaced by the QGPL38 version. You can:

1. Remove the QDSIGNON member in QGPL38/QDDSSRC.
2. Ensure there are no other members in QGPL/QDDSSRC.
3. Copy the other members from QGPL38.

- You can delete the following source file from QGPL38 assuming it was only used to hold print images (these were only used with system attached printers on System/38 and are not supported on the AS/400 system).

```
QIMGSRC      *FILE
```

- If you do not have a diskette device on the AS/400 system, you can delete the following objects from QGPL38. It is recommended that you leave the corresponding objects in QGPL in case you add a diskette device later. If you have a diskette device on the

AS/400 system and you have made changes to the QGPL38 objects, you need to consider making the same types of changes to the QGPL objects.

```
QDKT         *FILE
QDKTSRC      *FILE
QSPLDKTR     *JOB
QSPLDKTW     *JOB
QDKT         *OUTQ
```

- The following class objects in QGPL38 should have a corresponding class object in QGPL. If you have made changes to the QGPL38 objects, you need to consider making the same types of changes to the QGPL objects.

```
QBATCH       *CLS
QCTL         *CLS
QDIALLOCAL   *CLS
QFNC         *CLS
QINTER      *CLS
QPGMR        *CLS
QSNADS       *CLS
QSPL         *CLS
QSPL2        *CLS
```

The new default for the WAIT parameter for the OS/400 CRTCLS command is 30. You should consider this when converting your class objects.

- The following job description objects in QGPL38 should have a corresponding job description object in QGPL. If you have made changes to the QGPL38 objects, you need to consider making the same types of changes to the QGPL objects.

```
QBATCH       *JOB
QCTL         *JOB
QDIA         *JOB
QFNC         *JOB
QHOSTPRT     *JOB
QINTER      *JOB
QNFTP        *JOB
QPGMR        *JOB
QSNADS       *JOB
QSPLDBR      *JOB
QSPLERRROR   *JOB
QSPLPRTW     *JOB
```

- The following job queue objects in QGPL38 should have a corresponding job queue object in QGPL. If you have made changes to QGPL38 objects, you need to consider making the same types of changes to the QGPL objects.

QCTL	*JOBQ
QBATCH	*JOBQ
QFNC	*JOBQ
QINTER	*JOBQ
QPGMR	*JOBQ
QSNADS	*JOBQ
QSPL	*JOBQ

- The following output queue objects in QGPL38 should have a corresponding output queue object in QGPL. If you have made changes to the QGPL38 objects, you need to consider making the same types of changes to the QGPL objects.

QPRINT	*OUTQ
QPRINT2	*OUTQ
QPRINTS	*OUTQ

- The following printer device file objects in QGPL38 should have a corresponding printer device file object in QGPL. If you have made changes to the QGPL38 objects, you need to consider making the same types of changes to the QGPL objects.

QPRINT	*FILE
QPRINT2	*FILE
QPRINTS	*FILE

- The following subsystem description objects in QGPL38 should have a corresponding subsystem description object in QGPL or QSYS. If you have made changes to the QGPL38 objects, you need to consider making the same types of changes to the corresponding objects in QGPL or QSYS.

QINTER	*SBSD
QBATCH	*SBSD
QFNC	*SBSD
QSPL	*SBSD
QPGMR	*SBSD
QSNADS	*SBSD

You need both a QCMD and QCMD38 routing entry. The IBM-supplied version in QGPL is shipped this way. See "Subsystem Description" on page 2-52.

You should be careful in determining the JOBID value specified for the work station entries on the interactive subsystem. The

AS/400 version uses the JOBID associated with the user profile as the default. This may cause a different job description to be assigned.

The QCTL subsystem was shipped on System/38 in the QSYS library. It was recommended that you not change this object, but, if you needed to make changes, you created your own controlling subsystem. For example, you may have created a subsystem named QCTL2 in QGPL. This subsystem should be reviewed for changes.

- At this point, the QGPL38 library should only contain the objects that were not being used by CPF on Release 8 or objects that you have created beginning with the letter Q. You need to consider if these objects should be moved to QGPL. After you have accounted for these objects, you can delete QGPL38.

QSYS objects: If you make changes to QSYS objects (for example, print files, command authorization) on a new release, you should now make the same changes. In some cases, you will find that print file or command names have changed.

Sign-on display: If you have a user defined sign-on display (for example, a company personalized version), it should be changed to account for the new input fields on the IBM Sign-On display. The *Work Management Guide* contains more information.

Command authorization: If you authorized certain IBM commands (for example, CRTPF) on System/38 to specific individuals, you should consider your security strategy. Many of the commands that were not public on System/38 are public on the AS/400 system. You may be able to remove some individual authorizations.

User version of IBM commands: If you have created your own version of IBM commands, you may want to create and use the QUSER38 library and place your System/38 version of the command in the library. See the discussion in Chapter 1. The OS/400 version of the command can use the same approach you used on System/38, but the parameter list may have changed. If you have created validity-checking programs for IBM commands, you need to consider the same type of changes.

SNADS configuration: If you are using SNADS, you should reenter the SNADS configuration. Use the information you printed as described previously and the CFGDSTSRV command. See also "SNADS" on page 2-47.

Alerts: If you are using Alerts, you should enter the network attributes that control Alerts. Use the values you printed in the steps "What You Should Do on System/38 before You Migrate" on page 7-1. Enter the system name for your AS/400 system.

Diskette device name: If you have a diskette device, you should consider creating a diskette device with the name of QDKT. See "Diskette" on page 2-10.

Tape device name: If you are using automatic device configuration and want to name your tape device something other than TAP01, see "Tape" on page 2-58.

Exchange ID: If you use SNA to communicate with other systems, you should consider the name you want for the exchange ID. See "Exchange ID" on page 5-1.

Migration aid: Delete the Migration Aid. See the instructions in the *System/38 to AS/400 Migration Aid User's Guide and Reference*.

Appendix A. System/38 Commands and Command Definitions

This appendix describes the System/38 commands and the changes and additions that have occurred. The new OS/400 commands are not described. Only the following are described:

- Command name changes
- Parameter name changes and new parameters
- Parameter value changes and new values
- Default changes

For some commands, the maximum number of positional parameters (MAXPOS) has been reduced in the OS/400 program compared to the System/38 environment. The CVTCLSRC command does not detect all of these changes. They are detected when the converted programs are compiled.

In some cases, you may be referred to other discussions in this manual or to the *CL Reference* manual.

The following describes the columns that appear in Figure A-1:

- All System/38 commands are listed in the left column.

Note: The full list of OS/400 commands is not included.

System/38 commands are allowed to be entered using the Source Entry Utility (SEU) in the System/38 environment. However, not all commands can be run in the System/38 environment. See the next column.

- The *System/38 Environment Run* column has Xs for those commands that run in the System/38 environment.

The commands that show blanks in this column are only allowed to be entered into SEU for the System/38 source types of CL38 and CLP38. The intent of this support is to allow for maintenance of System/38 programs and job streams on the AS/400 system. The CL must be moved to a System/38 to be run. If a command with a

blank in this column is attempted on the AS/400 system (in either the System/38 environment or the OS/400 program) an escape message is issued stating Function not supported.

- The *OS/400 New Command* column has Xs where the same command name can be run in the OS/400 program or the name of the *New Command* (if different) that replaces the System/38 command in the OS/400 program.
- The *Comments* column provides information to assist you in determining what is different. For more details about the changes that have been made, see the *CL Reference* manual.

If the *OS/400 New Command* column is blank, the command cannot be run in the OS/400 program. Either the function is done differently or a new approach is used.

Some functions will not be described for each command because they apply to many commands.

The *CURLIB value can be specified for most commands in the OS/400 program where the parameters support a library qualifier. The default remains the same unless otherwise noted.

Command Definition Statements

No distinction has been made between System/38 environment or OS/400 command definition source. The CRTCMD command in either the System/38 environment or the OS/400 program creates the same form of object (there is no TYPE for command definition object). See the "Command Definition" on page 2-2 and "Command Definition" on page 4-3.

To define the layered prompts, the new command definition statement PMPTCTL exists with an additional PARM command.

Figure A-1 (Page 1 of 39). System/38 Commands

System/38 Command	System/38 Environment Run	OS/400 New Command	Comments
ADDACC	X	X	
ADDAJE	X	X	
ADDBKP	X	X	
ADDBSCDEVE	X		Mixed, communications, and BSC files are replaced in the OS/400 program by ICF files. See "Data Description Specifications (DDS)" on page 4-4.
ADDCMNDEVE	X		Mixed, communications, and BSC files are replaced in the OS/400 program by ICF files. See "Data Description Specifications (DDS)" on page 4-4.
ADDCMNE	X	X	The DEV parameter is changed in the System/38 environment. The OS/400 program adds the RMTLOCNAME parameter.
ADDDEVMODE			The device mode function has changed. There is a new object type for device modes. See "Device Configuration" on page 2-7.
ADDDSPDEVE	X		Mixed, communications, and BSC files are replaced in the OS/400 program by ICF files. See "Data Description Specifications (DDS)" on page 4-4.
ADDFCTE	X	X	
ADDJOBQE	X	X	The job queue function changes to allow the new parameter of MAXPTYn in the OS/400 program.
ADDLFM	X	X	The ACCPTHMBR parameter is ignored in the System/38 environment and not supported in the OS/400 program.
ADDLIBLE	X	X	
ADDMSGD	X	X	The PDPCODE and LOG parameters are ignored in the System/38 environment and are not supported in the OS/400 program. The OS/400 program command supports the LOGPRB parameter. The ALRID keyword has been renamed to ALROPT in the OS/400 program. The values have changed for this keyword in both environments. The SECLVL keyword supports up to 3000 characters in the OS/400 program (1435 in the System/38 environment). Both environments allow special control characters to be entered into the message text to assist in formatting.
ADDNETJOBE	X	X	
ADDPFM	X	X	
ADDPGM	X	X	The user must have *CHANGE authority to debug a program instead of the read right on System/38.
ADDRJECMNE	X	X	
ADDRJERDRE	X	X	
ADDRJEWTR	X	X	
ADDRPYLE	X	X	
ADDRTGE	X	X	
ADDTRC	X	X	
ADDWSE	X	X	The default in the OS/400 program changes to JOBD(*USRPRF). See "Subsystem Description" on page 2-52. The valid WRKSTNTYPE values have changed.
ADDXDMNK	X	ADDCRSDMNK	
ALCOBJ	X	X	New values for object types (for example, *MENU) are valid with the OS/400 commands. The new values are not valid for the System/38 environment commands.

Figure A-1 (Page 2 of 39). System/38 Commands

System/38 Command	System/38 Environment Run	OS/400 New Command	Comments
ANSLIN	X	X	
APYJRNCHG	X	X	
APYPGMCHG		APYPTF	The PGMID parameter has changed to LICPGM and is required. PGM is no longer supported. A new parameter IPLAPY exists to allow an automatic apply of delayed PTFs at the next unattended IPL. The LIB parameter is not supported in the OS/400 program.
BGNBAS	X	STRBAS	
BGNCMTCTL	X	STRCMTCTL	
BGNIWSSRV			The BGNIWSSRV command is replaced by APPN/ICF support. The EXITPGM keyword is replaced by the network attribute PCSACC.
BGNPASTHR	X	STRPASTHR	For the OS/400 program, new parameters exist for MODE, RMTLOCNAME, LCLLOCNAME and RMTNETID. For the OS/400 program, the MODE parameter defaults to *NETATR on the STRPASTHR command. In the System/38 environment, the BGNPASTHR command uses the first mode for each device. The VRTCTLU parameter changes to VRTCTL in the OS/400 program. The VRTCTL and VRTDEV parameters do not need to be specified in the OS/400 program although one of these parameters can still be specified. The OS/400 command supports the new parameters RMTUSER, RMPWD, RMTINLPGM, RMTINLMNU, RMTCURLIB, and PASTHRSCN.
BRWPFM	X	DSPPFM	
CALL	X	X	
CFGDSTSRV	X	X	The NDEID parameter is ignored on the System/38 environment command and not supported for the OS/400 command.
CHGACGCDE	X	X	
CHGAJE	X	X	
CHGBSCF	X		Mixed, communications, and BSC files are replaced in the OS/400 program by ICF files. Both a CHGICFF and a CHGICFDEVE command may be necessary. See "Data Description Specifications (DDS)" on page 4-4.
CHGCMD	X	X	The OS/400 program version of the commands support the new ALWMTUSR, CURLIB, and PRDLIB parameters. The CHGCMD command must explicitly specify the QSYS38 or QUSR38 library when you want to change a command in QSYS38 or QUSR38, respectively.
CHGCMDDFT	X	X	To change a System/38 environment command, you must qualify the command (for example QSYS38/CHGJOB).
CHGCMNE	X	X	The DEV parameter is changed in the System/38 environment. The OS/400 program adds the RMTLOCNAME parameter.
CHGCMNF	X		Mixed, communications, and BSC files are replaced in the OS/400 program by ICF files. Both a CHGICFF and a CHGICFDEVE command may be necessary. See "Data Description Specifications (DDS)" on page 4-4.
CHGCNPA			The CSNAP function does not exist on the OS/400 program. Some of the same function may be achieved by the device configuration THRESHOLD parameter.
CHGCRDF			Card devices are not supported on the AS/400 system.

Figure A-1 (Page 3 of 39). System/38 Commands

System/38 Command	System/38 Environment Run	OS/400 New Command	Comments
CHGCUD			The CHG device configurations commands have changed. Use CHGCTLxxxx, where xxxx is the controller class or type. For example, use CHGCTLAPPC for APPC. See "Device Configuration" on page 2-7.
CHGDBG	X	X	
CHGDDMF	X	X	The MODE parameter value *FIRST changes to *NETATR in the OS/400 program. The MODE parameter value *BLANK changes to BLANK in the OS/400 program. See the discussion of DDM files in "Distributed Data Management (DDM)" on page 4-6.
CHGDEVD			The CHG device configurations commands have changed. Use CHGDEVxxxx where xxxx is the device class or type. For example, use CHGDEVPRP for printers. See "Device Configuration" on page 2-7.
CHGDEVMODE			The device mode function has changed. A new object type exists for device modes. See "Device Configuration" on page 2-7.
CHGDFUDEF	X		The System/38 DFU product is only supported in the System/38 environment. See the discussion for DFU/38 in Chapter 4.
CHGDKTF	X	X	The LOC parameter is ignored in the System/38 environment and not supported in the OS/400 commands. See "Diskette" on page 2-10 for a discussion of the need for a QDKT device description in the System/38 environment. For the OS/400 program, new parameters exist for OUTPTY and USRDTA.
CHGDOCOWN		CHGDLOWN	Documents are still stored in the object type *DOC. Because of the new object type for folder (*FLR), some commands which worked only on documents now work on both documents and folders. The DOC parameter changes to DLO in the OS/400 program. The abbreviation DLO means <i>document library object</i> and covers both types.
CHGDSPF	X	X	
CHGDTA	X		The System/38 DFU product is only supported in the System/38 environment. See the discussion for DFU/38 in Chapter 4. The CHGDTA command from the System/38 IDU product is supported in the System/38 environment. An OS/400 CHGDTA command is associated with the OS/400 DFU. These are not the same functions. Using CHGDTA in the OS/400 program will cause a search for an AS/400 DFU object. See the discussion on DFU in Chapter 2 and Chapter 4.
CHGDTAARA	X	X	
CHGFCT	X	X	
CHGFCTE	X	X	The STACKER and PRTIMG parameters are ignored in the System/38 environment and not supported in the OS/400 program.
CHGGRPA	X	X	
CHGHLLPTR	X	X	For the OS/400 program, the INVLVL parameter is renamed to RCRLVL.

Figure A-1 (Page 4 of 39). System/38 Commands

System/38 Command	System/38 Environment Run	OS/400 New Command	Comments
CHGJOB	X	X	CHGJOB is unchanged in the System/38 environment. In the OS/400 program, CHGJOB supports new keywords for PRTDEV, DATFMT, and DATSEP; the keyword EXCPTY is changed to RUNPTY. The OUTQ parameter supports the new values of *DEV and *USRPRF; and the JOBPTY parameter allows 0.
CHGJOBDB	X	X	The job description object in the OS/400 program has changed. A new parameter exists for PRTDEV; the CNLSEV parameter is renamed to ENDSEV; and the OUTQ parameter supports the new values of *DEV and *USRPRF.
CHGJOBQE	X	X	The job queue function changes to allow the new parameter of MAXPTYn in the OS/400 program.
CHGJRN	X	X	
CHGKBDMAP	X	X	The values *CFnn change to *Fnn for the OS/400 keywords PFnn through PA2PFnn.
CHGLF	X	X	The RECOVER parameter values have changed on OS/400 commands. *AFTSTRCPF becomes *AFTIPL, and *STRCPF becomes *IPL.
CHGLFM	X	X	
CHGLIB	X	X	
CHGLIND			The CHG device configurations command has changed. Use CHGLINxxxx, where xxxx is the line class or type, for example use CHGLINTRN for IBM Token-Ring Network. See "Device Configuration" on page 2-7.
CHGMSGD	X	X	The PDPCODE and LOG parameters are ignored in the System/38 environment and removed from the command in the OS/400 program. The OS/400 command supports the LOGPRB parameter. The ALRID keyword has been renamed to ALROPT in the OS/400 program. The values have changed for this keyword in both environments. The SECLVL keyword supports up to 3000 characters in the OS/400 program (1435 in the System/38 environment). Both environments allow special control characters to be entered into the message text to assist in formatting.
CHGMSGQ	X	X	
CHGMSTK	X	X	
CHGMXDF	X		Mixed, communications, and BSC files are replaced in the OS/400 program by ICF files. See "Data Description Specifications (DDS)" on page 4-4.
CHGNETA	X	X	See the discussion on "Network Attributes" on page 2-22. The alert network attributes have significantly changed. There are new attributes which can only be accessed from the OS/400 command. The SYSNAM parameter becomes SYSNAME in the OS/400 program.
CHGNETJOB	X	X	
CHGOBJD	X	X	New values for object types (for example, *MENU) are valid with the OS/400 commands. The new values are not valid for the System/38 environment commands.
CHGOBJOWN	X	X	New values for object types (for example, *MENU) are valid with the OS/400 commands. The new values are not valid for the System/38 environment commands.
CHGOUTQ	X	X	A new AUTCHK keyword is supported in the OS/400 program.

Figure A-1 (Page 5 of 39). System/38 Commands

System/38 Command	System/38 Environment Run	OS/400 New Command	Comments
CHGPF	X	X	On the OS/400 command, the RECOVER parameter values have changed. *AFTSTRCPF becomes *AFTIPL, and *STRCPF becomes *IPL.
CHGPFM	X	X	
CHGPGM	X	X	A new parameter, RMVOBS, has been added in the OS/400 program.
CHGPGMVAR	X	X	For the OS/400 program, the INVLVL parameter is renamed to RCRLVL.
CHGPRTF	X	X	<p>The parameters TRNTBL and PRTIMG are ignored for the System/38 environment command. The parameters are not supported on the OS/400 command.</p> <p>The System/38 parameter FORMSIZE is renamed PAGESIZE on the OS/400 commands.</p> <p>For OS/400 commands the following parameter changes have also occurred:</p> <ul style="list-style-type: none"> • DEV supports the new values *SYSVAL and *JOB. *NONE is not allowed. • PRTQLTY supports the new value *DEVD • FONT supports the new value *CPI • COPIES supports up to 255 copies (instead of 99) • New values are supported for the CPI, IGCCPI, and LPI parameters for DBCS printers only. <p>New parameters are supported for DUPLEX, JUSTIFY, OUTPTY, and USRDTA in the OS/400 program.</p> <p>On the OS/400 program, the System/38 DRAWER(3) value is replaced by DRAWER(*E1), and DRAWER(3) is used to select the third paper drawer.</p>
CHGPTR	X	X	<p>New values for object types (for example, *MENU) are valid with the OS/400 commands. The new values are not valid for the System/38 environment commands.</p> <p>For the OS/400 program, the INVLVL parameter is renamed to RCRLVL.</p>
CHGQRYDEF	X		The System/38 Query product is only supported in the System/38 environment. See "Query" on page 4-16.
CHGRJECMNE	X	X	
CHGRJERDRE	X	X	
CHGRJEWTR	X	X	
CHGRPYLE	X	X	
CHGRTGE	X	X	
CHGSAVF	X	X	
CHGSBSD	X	X	Pool size minimum is 32K instead of 16K as on System/38.
CHGSPLFA	X	X	<p>The parameters TRNTBL and PRTIMG are ignored for the System/38 environment command. The parameters are not supported for the OS/400 command.</p> <p>The OS/400 command supports the new keywords SELECT, DEV, PRTSEQ, OUTPTY, USRDTA, and ALIGN. New keyword and values are supported for OUTQ(*DEV), FILE(*SELECT), and PRTQLTY(*DEVD).</p> <p>A new parameter, DUPLEX, has been added in the OS/400 program.</p>
CHGSRCPF	X	X	The RECOVER parameter values have changed on the OS/400 commands. *AFTSTRCPF becomes *AFTIPL, and *STRCPF becomes *IPL.
CHGSSND	X	X	

Figure A-1 (Page 6 of 39). System/38 Commands

System/38 Command	System/38 Environment Run	OS/400 New Command	Comments
CHGSSNMAX	X	X	For the OS/400 program, new parameters exist for RMTLOCNAME, LLCLOCNAME, and RMTNETID. Instead of being required in the OS/400 program, the MODE parameter defaults to *NETATR and the DEV parameter defaults to *LOC.
CHGSTGCFG			Configuration work is done through DST in a dedicated manner. See "Checksums" on page 2-2.
CHGSYSLIBL	X	X	
CHGSYSVAL	X	X	The list of system values has changed. Some System/38 values have been deleted, some have changed definitions, and new system values exist. Only OS/400 commands can access the new system values. See "System Values" on page 2-56 and the <i>Work Management Guide</i> for more details about system values.
CHGTAPF	X	X	The DENSITY parameter default is changed from 1600 to *DEVTYPE on the OS/400 command. New density values are supported. However, the DENSITY parameter value 800 is not supported. For the OS/400 program, SEQNBR supports the new values *END and *NEXT. The new parameter USRLBLPGM is supported in the OS/400 program.
CHGUSRPRF	X	X	New keywords and values are used with the OS/400 command. See "Security" on page 2-36. The GRPAUT value *NORMAL changes to *CHANGE in the OS/400 program. New parameters are supported in the OS/400 program.
CHGVAR	X	X	
CHGWSE	X	X	The valid WRKSTNTYPE values have changed from System/38.
CHGWTR	X	X	For the OS/400 CHGWTR command, the FILESEP parameter is added as well as the following values OUTQ(*DEV), FORMTYPE(*FORMS), and WTR(*SYSVAL).
CHGXDMNK	X	CHGCRSDMNK	
CHKDKT	X	X	The LOC parameter is ignored in the System/38 environment and not supported in the OS/400 command. *LOC is treated as *MOUNTED in the System/38 environment VOL parameter. The VOL parameter does not support the *LOC value in the OS/400 program. See "Diskette" on page 2-10 for a discussion of the need for a QDKT device description in the System/38 environment. The System/38 environment DEV parameter defaults to QDKT. The OS/400 DEV parameter requires a user-specified value.
CHKIGCTBL	X	X	
CHKOBJ	X	X	New values for object types (for example, *MENU) are valid with the OS/400 command. The new values are not valid for the System/38 environment command. AUT keyword parameter values are changed from *OPER to *USE and *NORMAL to *CHANGE.
CHKTAP	X	X	CHKTAP in the OS/400 program supports the new values of *NEXT and *FIRST for the SEQNBR.
CLCSTGCFG			The storage configuration commands do not operate on the AS/400 system. The calculation function is available through either DST or SST. See "Checksums" on page 2-2.

Figure A-1 (Page 7 of 39). System/38 Commands

System/38 Command	System/38 Environment Run	OS/400 New Command	Comments
CLNPRT			The CLNPRT command is not supported. This command refers only to system attached printers on System/38. Only work station attached printers are available on the AS/400 system.
CLOF	X	X	
CLRDKT	X	X	The LOC parameter is ignored in the System/38 environment and not supported in the OS/400 command. *LOC is treated as *MOUNTED in the System/38 environment VOL parameter. The VOL parameter in the OS/400 program does not support the *LOC value. See "Diskette" on page 2-10 for a discussion of the need for a QDKT device description in the System/38 environment. The System/38 environment DEV parameter defaults to QDKT. The OS/400 DEV parameter requires a user-specified value. The SUFFIX parameter is not supported in the OS/400 program.
CLRJOBQ	X	X	
CLRLIB	X	X	
CLROUTQ	X	X	
CLRPFM	X	X	
CLRSAVF	X	X	
CLRTRCDTA	X	X	
CMPJRNIMG	X	X	
CNLJOB	X	ENDJOB	The System/38 environment command CNLJOB becomes the OS/400 command ENDJOB. There is also a System/38 environment command named ENDJOB which becomes ENDBCHJOB in the AS/400 system.
CNLJOBABN	X	ENDJOBABN	
CNLNETF	X	DLTNETF	
CNLRCV	X	ENDRCV	
CNLRDR	X	ENDRDR	
CNLRJERDR	X	X	The CNL verb continues to be used in the OS/400 program to be similar to the System/370 terminology.
CNLRJEWTR	X	X	The CNL verb continues to be used in the OS/400 program to be similar to the System/370 terminology.
CNLRQS	X	ENDRQS	
CNLSPLF	X	DLTSPLF	For the OS/400 program, the SELECT parameter is added and FILE(*SELECT) is supported.
CNLWTR	X	ENDWTR	For the OS/400 program, WTR(*ALL) and WTR(*SYSVAL) are added.
COMMIT	X	X	
CPHDTA	X	X	
CPYF	X	X	The PRTFMT keyword is renamed to OUTFMT in the OS/400 program. The TOFILE value of *LIST has been changed to *PRINT. The effects of FMTOPT(*MAP) on DBCS fields have changed. See "Copy File (CPYF)" on page 2-4 for details about these fields. DDM files can be specified as both a FROMFILE and a TOFILE. Copy file (CPYF) allows a remote file to be created with DDM.

Figure A-1 (Page 8 of 39). System/38 Commands

System/38 Command	System/38 Environment Run	OS/400 New Command	Comments
CPYFRMDKT	X	X	<p>The FROMLOC parameter is ignored in the System/38 environment and not supported in the OS/400 command. See "Diskette" on page 2-10 for a discussion of the need for a QDKT device description in the System/38 environment.</p> <p>New parameters exist in the OS/400 program for FROMDEV.</p> <p>The PRTFMT keyword is renamed to OUTFMT in the OS/400 program. The TOFILE value of *LIST has been changed to *PRINT.</p>
CPYFRMTAP	X	X	<p>The PRTFMT keyword is renamed to OUTFMT in the OS/400 program. The TOFILE value of *LIST has been changed to *PRINT.</p> <p>For the OS/400 program, FROMSEQNBR supports the new value *NEXT.</p>
CPYFRMVDSK		CPYFRMPCD	Replaced by folder support.
CPYIGCTBL	X	X	The LOC parameter is ignored in the System/38 environment and not supported in the OS/400 command. See "Diskette" on page 2-10 for a discussion of the need for a QDKT device description in the System/38 environment.
CPYSPLF	X	X	The OS/400 CPYSPLF command supports the new keyword/value CTLCHAR(*S36FMT).
CPYSRCF	X	X	<p>The TOFILE value of *LIST has been changed to *PRINT.</p> <p>DDM files can be specified as both a FROMFILE and a TOFILE.</p>
CPYTODKT	X	X	<p>The TOLOC parameter is ignored in the System/38 environment and not supported in the OS/400 command. See "Diskette" on page 2-10 for a discussion of the need for a QDKT device description in the System/38 environment.</p> <p>New parameters exist in the OS/400 program for TODEV.</p>
CPYTOTAP	X	X	<p>The default for the TORCDLEN parameter has been changed from *TAPF to *FROMFILE.</p> <p>For the OS/400 program, TOSEQNBR supports the new value *END.</p>
CPYTOVDSK		CPYTOPCD	Replaced by folder support.
CRTBASPGM	X	X	<p>The PUBAUT keyword has changed to AUT and the values have changed in the OS/400 program. See "Security" on page 2-36. The default library qualifier in the OS/400 program has changed to *CURLIB. See "Library" on page 4-9.</p> <p>The REPLACE option is supported and *YES is the default for the OS/400 command. The REPLACE(*NO) function is implicitly requested by the System/38 environment command.</p> <p>For the OS/400 program, the OPTION parameter supports a new value to select if second-level message text should be printed.</p>
CRTBSCF	X		Mixed, communications, and BSC files are replaced in the OS/400 program by ICF files. Both a CRTICFF and an ADDICFDEVE command may be required. See "Data Description Specifications (DDS)" on page 4-4.

Figure A-1 (Page 9 of 39). System/38 Commands

System/38 Command	System/38 Environment Run	OS/400 New Command	Comments
CRTCBLPGM	X	X	<p>The PUBAUT keyword has changed to AUT and the values have changed in the OS/400 program. See "Security" on page 2-36. The default library qualifier in the OS/400 program has changed to *CURLIB. See "Library" on page 4-9.</p> <p>The REPLACE option is supported and *YES is the default for the OS/400 command. The REPLACE(*NO) function is implicitly requested by the System/38 environment command.</p> <p>For the OS/400 program, the OPTION parameter supports a new value to select if second-level message text should be printed.</p> <p>In the OS/400 program, the FIPS parameter has changed to FLAGSTD and the values have changed to comply with the new FIPS 1986 standard.</p> <p>In the OS/400 program, the new parameter TGTRLS is supported.</p>
CRTCLPGM	X	X	<p>The PUBAUT keyword has changed to AUT and the values have changed in the OS/400 program. See "Security" on page 2-36. The default library qualifier in the OS/400 program has changed to *CURLIB. See "Library" on page 4-9.</p> <p>The REPLACE option is supported and defaults to *YES for the OS/400 command. The REPLACE(*NO) function is implicitly requested by the System/38 environment command.</p> <p>For the OS/400 program, the OPTION parameter supports a new value to select if second-level message text should be printed.</p> <p>In the OS/400 program, the new parameter TGTRLS is supported.</p>
CRTCLS	X	X	<p>The PUBAUT keyword has changed to AUT and the values have changed in the OS/400 program. See "Security" on page 2-36. The default library qualifier in the OS/400 program has changed to *CURLIB. See "Library" on page 4-9.</p> <p>The CLASS object default in the OS/400 command for DFTWAIT changes from 120 to 30. The EXCPTY keyword name changes to RUNPTY in the OS/400 program.</p>
CRTCMD	X	X	<p>The PUBAUT keyword has changed to AUT and the values have changed in the OS/400 program. See "Security" on page 2-36. The default library qualifier in the OS/400 program has changed to *CURLIB. See "Library" on page 4-9.</p> <p>The OS/400 program version of the command supports the new ALWLMTUSR, CURLIB, and PRDLIB parameters.</p> <p>The CRTCMD command must explicitly specify the QSYS38 or QUSR38 library when you want to create a command in QSYS38 or QUSR38, respectively.</p>
CRTC MNF	X		<p>Mixed, communications, and BSC files are replaced in the OS/400 program by ICF files. Both a CRTICFF and an ADDICFDEVE command may be necessary. See "Data Description Specifications (DDS)" on page 4-4.</p>
CRTC RDF			<p>Card devices are not supported on the AS/400 system.</p>
CRTC UD			<p>The CRT device configurations commands have changed. Use CRTCTLxxxx where xxxx is the controller class or type. For example, use CRTCTLAPPC for APPC. See "Device Configuration" on page 2-7.</p>

Figure A-1 (Page 10 of 39). System/38 Commands

System/38 Command	System/38 Environment Run	OS/400 New Command	Comments									
CRTDDMF	X	X	<p>See the discussion of DDM files in "Distributed Data Management (DDM)" on page 4-6.</p> <p>The MODE parameter value *FIRST changes to *NETATR in the OS/400 program. The MODE parameter value *BLANK changes to BLANK in the OS/400 program.</p> <p>The PUBAUT keyword has changed to AUT and the values have changed in the OS/400 program. See "Security" on page 2-36. The default library qualifier in the OS/400 program has changed to *CURLIB. See "Library" on page 4-9.</p>									
CRTDEVD			<p>The CRT device configurations commands have changed. Use CRTDEVXXX where XXXX is the device class or type. For example, use CRTDEVPRT for printers. See "Device Configuration" on page 2-7.</p>									
CRTDFUAPP	X		<p>The System/38 DFU product is only supported in the System/38 environment. See "Data File Utility (DFU)" on page 4-16.</p>									
CRTDFUDEF	X		<p>The System/38 DFU product is only supported in the System/38 environment. See "Data File Utility (DFU)" on page 4-16.</p>									
CRTDKTF	X	X	<p>The LOC parameter is ignored in the System/38 environment and not supported in the OS/400 command. See "Diskette" on page 2-10 for a discussion of the need for a QDKT device description in the System/38 environment.</p> <p>The PUBAUT keyword has changed to AUT and the values have changed in the OS/400 program. See "Security" on page 2-36. The default library qualifier in the OS/400 program has changed to *CURLIB. See "Library" on page 4-9.</p> <p>The following defaults have changed:</p> <table border="1"> <thead> <tr> <th>Keyword</th> <th>System/38 Environment Default</th> <th>OS/400 Program Default</th> </tr> </thead> <tbody> <tr> <td>MAXRCDS</td> <td>20000</td> <td>100000</td> </tr> <tr> <td>SCHEDULE</td> <td>*JOBEND</td> <td>*FILEEND</td> </tr> </tbody> </table> <p>For the OS/400 program, new parameters exist for OUTPTY and USRDTA.</p>	Keyword	System/38 Environment Default	OS/400 Program Default	MAXRCDS	20000	100000	SCHEDULE	*JOBEND	*FILEEND
Keyword	System/38 Environment Default	OS/400 Program Default										
MAXRCDS	20000	100000										
SCHEDULE	*JOBEND	*FILEEND										
CRTDSPF	X	X	<p>The PUBAUT keyword has changed to AUT and the values have changed in the OS/400 program. See "Security" on page 2-36. The default library qualifier in the OS/400 program has changed to *CURLIB. See "Library" on page 4-9.</p> <p>For the OS/400 program, the OPTION parameter supports a new value to select if second-level message text should be printed.</p>									
CRTDTAARA	X	X	<p>The PUBAUT keyword has changed to AUT and the values have changed in the OS/400 program. See "Security" on page 2-36. The default library qualifier in the OS/400 program has changed to *CURLIB. See "Library" on page 4-9.</p>									
CRTDTAQ	X	X	<p>The PUBAUT keyword has changed to AUT and the values have changed in the OS/400 program. See "Security" on page 2-36. The default library qualifier in the OS/400 program has changed to *CURLIB. See "Library" on page 4-9.</p>									

Figure A-1 (Page 11 of 39). System/38 Commands

System/38 Command	System/38 Environment Run	OS/400 New Command	Comments
CRTDUPOBJ	X	X	<p>New values for object types (for example, *MENU) are valid with the OS/400 command. The new values are not valid for the System/38 environment command. The *SPADCT object type is not supported in either the System/38 environment or the OS/400 program.</p> <p>In the System/38 environment, the *PRTIMG object type, if specified, is not supported. It exists to allow for source to be moved to System/38. In the OS/400 program, the *PRTIMG object type cannot be specified.</p>
CRTEDTD	X	X	<p>The PUBAUT keyword has changed to AUT and the values have changed in the OS/400 program. See "Security" on page 2-36.</p>
CRTFCT	X	X	<p>The PUBAUT keyword has changed to AUT and the values have changed in the OS/400 program. See "Security" on page 2-36. The default library qualifier in the OS/400 program has changed to *CURLIB. See "Library" on page 4-9.</p>
CRTGSS	X	X	<p>The PUBAUT keyword has changed to AUT and the values have changed in the OS/400 program. See "Security" on page 2-36. The default library qualifier in the OS/400 program has changed to *CURLIB. See "Library" on page 4-9.</p>
CRTIGCDCT	X	X	<p>The PUBAUT keyword has changed to AUT and the values have changed in the OS/400 program. See "Security" on page 2-36. The default library qualifier in the OS/400 program has changed to *CURLIB. See "Library" on page 4-9.</p>
CRTJOBQ	X	X	<p>The PUBAUT keyword has changed to AUT and the values have changed in the OS/400 program. See "Security" on page 2-36. The default library qualifier in the OS/400 program has changed to *CURLIB. See "Library" on page 4-9.</p> <p>The defaults for the following parameters change in the OS/400 program.</p> <pre>LOG(4 0 *NOLIST) RTGDTA(QCMDI) OUTQ(*USRPRF)</pre> <p>The OS/400 program supports a new parameter for PRTDEV; the CNLSEV parameter changes to ENDSEV; and the OUTQ parameter supports the new values of *DEV and *USRPRF.</p>
CRTJOBQ	X	X	<p>The PUBAUT keyword has changed to AUT and the values have changed in the OS/400 program. See "Security" on page 2-36. The default library qualifier in the OS/400 program has changed to *CURLIB. See "Library" on page 4-9. A new AUTCHK parameter has been added.</p>
CRTJRN	X	X	<p>The PUBAUT keyword has changed to AUT and the values have changed in the OS/400 program. See "Security" on page 2-36. The default library qualifier in the OS/400 program has changed to *CURLIB. See "Library" on page 4-9.</p>
CRTJRNRCV	X	X	<p>The PUBAUT keyword has changed to AUT and the values have changed in the OS/400 program. See "Security" on page 2-36. The default library qualifier in the OS/400 program has changed to *CURLIB. See "Library" on page 4-9.</p>

Figure A-1 (Page 12 of 39). System/38 Commands

System/38 Command	System/38 Environment Run	OS/400 New Command	Comments
CRTLF	X	X	<p>The PUBAUT keyword has changed to AUT and the values have changed in the OS/400 program. See "Security" on page 2-36. The default library qualifier in the OS/400 program has changed to *CURLIB. See "Library" on page 4-9.</p> <p>The ACCPTHMBR parameter is ignored in the System/38 environment and not supported in the OS/400 program.</p> <p>The RECOVER parameter values have changed on the AS/400 commands. *AFTSTRCPF becomes *AFTIPL, and *STRCPF becomes *IPL.</p> <p>For the OS/400 program, the OPTION parameter supports a new value to select if second-level message text should be printed.</p> <p>For the OS/400 program, the SYSTEM parameter is added to designate the location of the system.</p>
CRTLIB	X	X	<p>The PUBAUT keyword has changed to AUT and the values have changed in the OS/400 program. See "Security" on page 2-36.</p>
CRTLIND			<p>The CRT device configurations commands have changed. Use CRTLINxxxx where xxxx is the line class or type. For example, use CRTLINTRN for IBM Token-Ring Network. See "Device Configuration" on page 2-7.</p>
CRTMSGF	X	X	<p>The PUBAUT keyword has changed to AUT and the values have changed in the OS/400 program. See "Security" on page 2-36. The default library qualifier in the OS/400 program has changed to *CURLIB. See "Library" on page 4-9.</p>
CRTMSGQ	X	X	<p>The PUBAUT keyword has changed to AUT and the values have changed in the OS/400 program. See "Security" on page 2-36. The default library qualifier in the OS/400 program has changed to *CURLIB. See "Library" on page 4-9.</p> <p>The SENDER parameter is ignored in the System/38 environment. All message queues are treated as SENDER(*JOB *PGM *DTS). The parameter is not supported in the OS/400 program.</p> <p>For the OS/400 program, the CRTMSGQ SIZE parameter uses (3 1 *NOMAX) as the default instead of (3 1 3).</p>
CRTMXDF	X		<p>Mixed, communications, and BSC files are replaced in the OS/400 program by ICF files. See "Data Description Specifications (DDS)" on page 4-4.</p>
CRTOUTQ	X	X	<p>The CRTOUTQ JOBSEP default changes on the OS/400 command from 1 to 0. The SEQ default changes from *JOBNBR to *FIFO.</p> <p>The PUBAUT keyword has changed to AUT and the values have changed in the OS/400 program. See "Security" on page 2-36. The default library qualifier in the OS/400 program has changed to *CURLIB. See "Library" on page 4-9. A new AUTCHK parameter has been added.</p>

Figure A-1 (Page 13 of 39). System/38 Commands

System/38 Command	System/38 Environment Run	OS/400 New Command	Comments
CRTPF	X	X	<p>The PUBAUT keyword has changed to AUT and the values have changed in the OS/400 program. See "Security" on page 2-36. The default library qualifier in the OS/400 program has changed to *CURLIB. See "Library" on page 4-9.</p> <p>The RECOVER parameter values have changed on the OS/400 commands. *AFTSTRCPF becomes *AFTIPL, and *STRCPF becomes *IPL.</p> <p>For the OS/400 program, new parameters exist for ALWUPD, ALWDLT, and SYSTEM.</p> <p>For the OS/400 program, the OPTION parameter supports a new value to select if second-level message text should be printed.</p>
CRTPLIPGM	X	X	<p>The PUBAUT keyword has changed to AUT and the values have changed in the OS/400 program. See "Security" on page 2-36. The default library qualifier in the OS/400 program has changed to *CURLIB. See "Library" on page 4-9.</p> <p>The REPLACE option is supported and *YES is used for the default for the OS/400 command. The REPLACE(*NO) function is implicitly requested by the System/38 environment command.</p> <p>For the OS/400 program, the OPTION parameter supports a new value to select if second-level message text should be printed.</p>

Figure A-1 (Page 14 of 39). System/38 Commands

System/38 Command	System/38 Environment Run	OS/400 New Command	Comments																		
CRTPRTF	X	X	<p>The parameters TRNTBL and PRTIMG are ignored for the System/38 environment command. The parameters are not supported on the OS/400 command.</p> <p>The PUBAUT keyword has changed to AUT and the values have changed in the OS/400 program. See "Security" on page 2-36.</p> <p>The default library qualifier in the OS/400 program has changed to *CURLIB. See "Library" on page 4-9.</p> <p>The System/38 parameter FORMSIZE is renamed PAGESIZE on the OS/400 command.</p> <p>The following defaults have changed for the CRT command:</p> <table border="1"> <thead> <tr> <th>Keyword</th> <th>System/38 Environment Default</th> <th>OS/400 Program Default</th> </tr> </thead> <tbody> <tr> <td>DEV</td> <td>*NONE</td> <td>*JOB</td> </tr> <tr> <td>OUTQ</td> <td>*JOB</td> <td>*JOB</td> </tr> <tr> <td>FONT</td> <td>*DEVD</td> <td>*CPI</td> </tr> <tr> <td>MAXRCDS</td> <td>20000</td> <td>100000</td> </tr> <tr> <td>SCHEDULE</td> <td>*JOBEND</td> <td>*FILEEND</td> </tr> </tbody> </table> <p>For OS/400 commands the following parameter changes have also occurred:</p> <ul style="list-style-type: none"> • DEV supports the new values *SYSVAL and *JOB. *NONE is not allowed. • PRTQLTY supports the new value *DEVD. • FONT supports the new value *CPI. • COPIES supports up to 255 copies (instead of 99). • New values are supported for the CPI, IGCCPI, and LPI parameters for DBCS printers only. <p>New parameters are supported for DUPLEX, JUSTIFY, OUTPTY, and USRDTA in the OS/400 program.</p> <p>For the OS/400 program, the OPTION parameter supports a new value to select if second-level message text should be printed.</p> <p>On the OS/400 program, the System/38 DRAWER(3) value is replaced by DRAWER(*E1), and DRAWER(3) is used to select the third paper drawer.</p>	Keyword	System/38 Environment Default	OS/400 Program Default	DEV	*NONE	*JOB	OUTQ	*JOB	*JOB	FONT	*DEVD	*CPI	MAXRCDS	20000	100000	SCHEDULE	*JOBEND	*FILEEND
Keyword	System/38 Environment Default	OS/400 Program Default																			
DEV	*NONE	*JOB																			
OUTQ	*JOB	*JOB																			
FONT	*DEVD	*CPI																			
MAXRCDS	20000	100000																			
SCHEDULE	*JOBEND	*FILEEND																			
CRTPRTIMG			<p>This command refers only to system attached printers on System/38. Only work station attached printers are available on the AS/400 system.</p>																		
CRTQRYAPP	X		<p>The System/38 Query product is only supported in the System/38 environment. See "Query" on page 4-16.</p>																		
CRTQRYDEF	X		<p>The System/38 Query product is only supported in the System/38 environment. See "Query" on page 4-16.</p>																		
CRTRJECFG	X	X																			

Figure A-1 (Page 15 of 39). System/38 Commands

System/38 Command	System/38 Environment Run	OS/400 New Command	Comments
CRTRPGPGM	X	X	<p>The PUBAUT keyword has changed to AUT and the values have changed in the OS/400 program. See "Security" on page 2-36. The default library qualifier in the OS/400 program has changed to *CURLIB. See "Library" on page 4-9.</p> <p>The REPLACE option is supported and defaults to *YES for the OS/400 command. The REPLACE(*NO) function is implicitly requested by the System/38 environment command.</p> <p>For the OS/400 program, the OPTION parameter supports a new value to select if second-level message text should be printed.</p> <p>In the OS/400 program, the new parameter TGTRLS is supported.</p>
CRTRPTPGM	X	X	<p>The PUBAUT keyword has changed to AUT and the values have changed in the OS/400 program. See "Security" on page 2-36. The default library qualifier in the OS/400 program has changed to *CURLIB. See "Library" on page 4-9.</p> <p>The REPLACE option is supported and defaults to *YES for the OS/400 command. The REPLACE(*NO) function is implicitly requested by the System/38 environment command.</p> <p>For the OS/400 program, the OPTION parameter supports a new value to select if second-level message text should be printed.</p>
CRTSAVF	X	X	<p>The PUBAUT keyword has changed to AUT and the values have changed in the OS/400 program. See "Security" on page 2-36. The default library qualifier in the OS/400 program has changed to *CURLIB. See "Library" on page 4-9.</p>
CRTSBSD	X	X	<p>The PUBAUT keyword has changed to AUT and the values have changed in the OS/400 program. See "Security" on page 2-36. The default library qualifier in the OS/400 program has changed to *CURLIB. See "Library" on page 4-9.</p>
CRTSPADCT	X	X	<p>Pool size minimum is 32K instead of 16K as on System/38.</p> <p>The PUBAUT keyword has changed to AUT and the values have changed in the OS/400 program. The OS/400 command is similar to the System/38 command. The DCT parameter has changed to SPADCT. See "Dictionary 5714-DCT" on page 2-62.</p> <p>The BASDCT parameter changes to BASEDCT in the System/38 environment and in the OS/400 program.</p> <p>The <i>CL Reference</i> contains additional information. The DCT parameter changes to SPADCT in the OS/400 program.</p>
CRTSRCPF	X	X	<p>The PUBAUT keyword has changed to AUT and the values have changed in the OS/400 program. See "Security" on page 2-36. The default library qualifier in the OS/400 program has changed to *CURLIB. See "Library" on page 4-9.</p> <p>The RECOVER parameter values have changed on the AS/400 commands. *AFTSTRCPF becomes *AFTIPL, and *STRCPF becomes *IPL.</p> <p>For the OS/400 program, new parameters exist for ALWUPD, ALWDLT, and SYSTEM.</p>

Figure A-1 (Page 16 of 39). System/38 Commands

System/38 Command	System/38 Environment Run	OS/400 New Command	Comments
CRTSSND	X	X	The PUBAUT keyword has changed to AUT and the values have changed in the OS/400 program. See "Security" on page 2-36. The default library qualifier in the OS/400 program has changed to *CURLIB. See "Library" on page 4-9.
CRTTAPF	X	X	The PUBAUT keyword has changed to AUT and the values have changed in the OS/400 program. See "Security" on page 2-36. The default library qualifier in the OS/400 program has changed to *CURLIB. See "Library" on page 4-9. The DENSITY parameter default is changed from 1600 to *DEVTYPE on the OS/400 command. New density values are supported. The 800 value is not supported. The default for the RCDBLKfmt parameter has been changed from *F to *FB. For the OS/400 program, SEQNBR supports the new values *END and *NEXT.
CRTTBL	X	X	The PUBAUT keyword has changed to AUT and the values have changed in the OS/400 program. See "Security" on page 2-36. The default library qualifier in the OS/400 program has changed to *CURLIB. See "Library" on page 4-9.
CRTUSRPRF	X	X	Some of the System/38 environment parameters default differently to the AS/400 values. There are new keywords and values with the OS/400 command. See "Security" on page 2-36. The PUBAUT keyword has changed to AUT and the values have changed in the OS/400 program. See "Security" on page 2-36. New parameters are supported in the OS/400 program.
CRTVDSK			Replaced by folder support.
CVTDAT	X	X	The OS/400 CVTDAT command supports the *JOB value for the FROMfmt, TOfmt, and TOSEP parameter. It is now the default. See "CL" on page 4-2.
CVTTOVDSK			Virtual diskette is not supported. You must convert the data to documents in folders.
DATA	X	X	
DCL	X	X	
DCLDTAARA	X		The DCLDTAARA command is not supported in the OS/400 program.
DCLF	X	X	The RTGDTA keyword is not supported in the OS/400 program.
DFNKBDMAP	X	SETKBDMAP	
DLCOBJ	X	X	New values for object types (for example, *MENU) are valid with the OS/400 command. The new values are not valid for the System/38 environment command.
DLTCHTFMT	X	X	
DLTCLS	X	X	
DLTCMD	X	X	The DLTCMD command must explicitly specify the QSYS38 or QUSR38 library when you want to delete a command in QSYS38 or QUSR38, respectively.
DLTCUD	X	DLTCTLD	The CUD parameter becomes CTLD in the OS/400 program.
DLTDEVd	X	X	

Figure A-1 (Page 17 of 39). System/38 Commands

System/38 Command	System/38 Environment Run	OS/400 New Command	Comments
DLTDFUAPP	X		The System/38 DFU product is only supported in the System/38 environment. See "Data File Utility (DFU)" on page 4-16.
DLTDKTLBL	X		The LOC parameter is ignored in the System/38 environment and not supported in the OS/400 command. *LOC is treated as *MOUNTED in the System/38 environment. The TOVOL parameter does not support the *LOC value in the OS/400 program. See "Diskette" on page 2-10 for a discussion of the need for a QDKT device description in the System/38 environment. The System/38 environment DEV parameter defaults to QDKT. The OS/400 DEV parameter requires a user-specified value. The SUFFIX parameter is not supported in the OS/400 program.
DLTDOC		DLTDLO	Documents are still stored in the object type *DOC. Because of the new object type for folder (*FLR), some commands that worked only on documents now work on both documents and folders. The DOC parameter is changed to DLO in the OS/400 program. The abbreviation DLO means <i>document library object</i> and covers both types. The PERIOD parameter is changed to CRTDATE in the OS/400 program.
DLTDOCL	X	X	
DLTDTAARA	X	X	
DLTDTAQ	X	X	
DLTEDTD	X	X	
DLTF	X	X	For the OS/400 program, the SYSTEM parameter is added to designate the location of the system.
DLTFCT	X	X	
DLTGSS	X	X	
DLTIGCDCT	X	X	
DLTIGCTBL	X	X	
DLTJOB	X	X	
DLTJOBQ	X	X	
DLTJRN	X	X	
DLTJRNRCV	X	X	
DLTLIB	X	X	
DLTLIND	X	X	
DLTMSGF	X	X	
DLTMSGQ	X	X	
DLTOUTQ	X	X	
DLTOVR	X	X	In the OS/400 program, FILE(*PRTF) is supported.
DLTPGM	X	X	
DLTPRTIMG			This command referred only to system attached printers on System/38. Only work station attached printers are available on the AS/400 system.
DLTQRYAPP	X		The System/38 Query product is only supported in the System/38 environment. See "Query" on page 4-16.
DLTRJECFG	X	X	
DLTSBSD	X	X	

Figure A-1 (Page 18 of 39). System/38 Commands

System/38 Command	System/38 Environment Run	OS/400 New Command	Comments
DLTSPADCT	X	X	The OS/400 command, DLTSPADCT, is similar to the System/38 command. The DCT parameter has changed to SPADCT. See "Dictionary 5714-DCT" on page 2-62. The <i>CL Reference</i> contains additional information. The DCT parameter changes to SPADCT in the OS/400 program.
DLTSSND	X	X	
DLTTBL	X	X	
DLTUSRPRF	X	X	
DLYJOB	X	X	
DMPCLPGM	X	X	
DMPJOB	X	X	
DMPJOBINT	X	X	
DMPOBJ	X	X	New values for object types (for example, *MENU) are valid with the OS/400 command. The new values are not valid for the System/38 environment command. The *PRTIMG object type is not supported in the OS/400 program.
DMPYSOJB	X	X	New values for object types (for example, *MENU) are valid with OS/400 commands. The new values are not valid for the System/38 environment commands.
DMPTAP	X	X	
DO	X	X	
DSNAPF	X	STRAPF	
DSNDFUAPP	X		The System/38 DFU product is only supported in the System/38 environment. See "Data File Utility (DFU)" on page 4-16.
DSNFMT	X	STRSDA	
DSNQRYAPP	X		The System/38 Query product is only supported in the System/38 environment. See "Query" on page 4-16.
DSPACC	X	X	The OUTPUT keyword value has changed from *LIST to *PRINT in the OS/400 program.
DSPACCAUT	X	X	The OUTPUT keyword value has changed from *LIST to *PRINT in the OS/400 program.
DSPACTJOB	X	WRKACTJOB	The command name has been changed to WRK, but the function is the same in the OS/400 program. The OUTPUT keyword value has changed from *LIST to *PRINT in the OS/400 program.
DSPAUTUSR	X	X	The OUTPUT keyword value has changed from *LIST to *PRINT in the OS/400 program.
DSPBKP	X	X	The OUTPUT keyword value has changed from *LIST to *PRINT in the OS/400 program.
DSPCHLSTS			The X.25 status information is not available on the AS/400 system.
DSPCHT	X	X	The OUTPUT keyword value has changed from *LIST to *PRINT in the OS/400 program.
DSPCLS	X	X	The OUTPUT keyword value has changed from *LIST to *PRINT in the OS/400 program.
DSPCMD	X	X	The OUTPUT keyword value has changed from *LIST to *PRINT in the OS/400 program. The DSPCMD command must explicitly specify the QSYS38 or QUSR38 library when you want to display a command in QSYS38 or QUSR38, respectively.

Figure A-1 (Page 19 of 39). System/38 Commands

System/38 Command	System/38 Environment Run	OS/400 New Command	Comments
DSPCNPA			The CSNAP function does not exist on the AS/400 system. Some of the same function may be achieved by the device configuration THRESHOLD parameter.
DSPCRPHLP			Help support is now available as a function key and not as a separate command.
DSPCTLSTS	X	WRKCFGSTS	The WRKCFGSTS command replaces DSPCTLSTS. The function is the same in the OS/400 program except that the OUTPUT parameter is not supported. The CTLU parameter changes to CFGD in the OS/400 program. The CFGTYPE parameter is new in the OS/400 program and is required.
DSPCUD	X	DSPCTLD	The OUTPUT keyword value has changed from *LIST to *PRINT in the OS/400 program. The CUD keyword changes to CTLD in the OS/400 program.
DSPDBG	X	X	The OUTPUT keyword value has changed from *LIST to *PRINT in the OS/400 program.
DSPDBR	X	X	The OUTPUT keyword value has changed from *LIST to *PRINT in the OS/400 program. The OUTPUT value of *NONE is specified as *OUTFILE on the AS/400 command. The OUTFILE value *NONE is not supported in the OS/400 program. The OS/400 command supports a new option on the OUTMBR parameter to allow you to control whether the member should be added to or replaced. The System/38 environment command implicitly does a replace. A default of *LIBL is used for the OS/400 program instead of *USRLIBL as in the System/38 environment.
DSPDEVCFG			The DSPDEVCFG command is not supported on the AS/400 system. See "Device Configuration" on page 2-7 for alternative solutions.
DSPDEVD	X	X	The OUTPUT keyword value has changed from *LIST to *PRINT in the OS/400 program.
DSPDEVSTS	X	WRKCFGSTS	The WRKCFGSTS command replaces DSPDEVSTS. The function is the same in the OS/400 program except for the OUTPUT parameter is not supported. The CFGTYPE parameter is new and is required in the OS/400 program. The DEV parameter changes to CFGD in the OS/400 program.
DSPDIR		X	The DSPDIR command is replaced by a similar OS/400 command that uses the same name. Additional parameters are supported. If you have DSPDIR in a System/38 program, you must specify DSPDIR.QSYS and prompt for the OS/400 program version. The OUTPUT parameter value *LIST changes to *PRINT in the OS/400 program.
DSPDKT	X	X	The LOC parameter is ignored in the System/38 environment and not supported in the OS/400 commands. See "Diskette" on page 2-10 for a discussion of the need for a QDKT device description in the System/38 environment. The System/38 environment DEV parameter defaults to QDKT. The OS/400 DEV parameter requires a user-specified value. The OUTPUT keyword value has changed from *LIST to *PRINT in the OS/400 program.
DSPDOCAUT		DSPUSRPMN	The OUTPUT parameter value *LIST changes to *PRINT in the OS/400 program.

Figure A-1 (Page 20 of 39). System/38 Commands

System/38 Command	System/38 Environment Run	OS/400 New Command	Comments
DSPDSTLOG	X	X	<p>The OUTPUT keyword value has changed from *LIST to *PRINT in the OS/400 program.</p> <p>The ENTTYPE parameter value *NST is supported in the System/38 environment. In the OS/400 program, it is changed to *DSQ.</p>
DSPDSTSRV	X	X	<p>The OUTPUT keyword value has changed from *LIST to *PRINT in the OS/400 program.</p> <p>The NDEID parameter is ignored on the System/38 environment commands and not supported for OS/400 commands.</p>
DSPDSTSTS	X	WRKDSTQ	<p>The command name has been changed to WRK, but the function is the same in the OS/400 program. The OUTPUT keyword value has changed from *LIST to *PRINT in the OS/400 program.</p> <p>The NDEID parameter is ignored on the System/38 environment commands and not supported for OS/400 commands.</p>
DSPDTA	X		<p>The System/38 DFU product is only supported in the System/38 environment. See "Data File Utility (DFU)" on page 4-16.</p> <p>The DSPDTA command from the System/38 IDU product is supported in the System/38 environment. An OS/400 DSPDTA command associated with the OS/400 DFU. These are not the same functions. Using DSPDTA in the OS/400 program causes a search for an OS/400 DFU object. See "IDU - DFU (Data File Utility) 5714-UT1" on page 2-62 and "Data File Utility (DFU)" on page 4-16.</p>
DSPDTAARA	X	X	<p>The OUTPUT keyword value has changed from *LIST to *PRINT in the OS/400 program.</p>
DSPEDTD	X	X	<p>The OUTPUT keyword value has changed from *LIST to *PRINT in the OS/400 program.</p>
DSPFCT	X	WRKFCT	<p>The command name has been changed to WRK, but the function is the same in the OS/400 program. The OUTPUT keyword value has changed from *LIST to *PRINT in the OS/400 program.</p>
DSPFD	X	X	<p>The OUTPUT keyword value has changed from *LIST to *PRINT in the OS/400 program.</p> <p>Card devices are not supported on the AS/400 system.</p> <p>The value of *CURLIB is valid for library parameters.</p> <p>The OUTPUT value of *NONE is specified as *OUTFILE on the AS/400 command. The OUTFILE value *NONE is not supported in the OS/400 program.</p> <p>The OS/400 command supports a new option on the OUTMBR parameter to allow you to control whether the member should be added to or replaced. The System/38 environment command implicitly does a replace.</p> <p>A default of *LIBL is used for the OS/400 program instead of *USRLIBL as in the System/38 environment.</p> <p>The OS/400 command supports new values on the file attribute (FILEATR) keyword that are consistent with the new source and object type.</p> <p>Some field values have changed. See "Cross-Reference" on page 2-5 for details.</p>

Figure A-1 (Page 21 of 39). System/38 Commands

System/38 Command	System/38 Environment Run	OS/400 New Command	Comments
DSPFFD	X	X	<p>The OUTPUT keyword value has changed from *LIST to *PRINT in the OS/400 program.</p> <p>The OUTPUT value of *NONE is specified as *OUTFILE on the OS/400 command. The OUTFILE value *NONE is not supported in the OS/400 program.</p> <p>The value of *CURLIB is valid for library parameters.</p> <p>The OS/400 command supports a new option on the OUTMBR parameter to allow you to control whether the member should be added to or replaced. The System/38 environment command implicitly does a replace.</p> <p>A default of *LIBL is used for the OS/400 program instead of *USRLIBL as in the System/38 environment.</p>
DSPFNCHLP			<p>Help support is now available as a function key and not as a separate command.</p>
DSPGDF	X	X	<p>The OUTPUT keyword value has changed from *LIST to *PRINT in the OS/400 program.</p>
DSPIGCDCT	X	X	<p>The OUTPUT keyword value has changed from *LIST to *PRINT in the OS/400 program.</p>
DSPJOB	X	X	<p>The OUTPUT keyword value has changed from *LIST to *PRINT in the OS/400 program.</p> <p>DSPJOB in the System/38 environment performs the same function it did on System/38 (changes are allowed). In the OS/400 program, the command does a display-only function. The new command WRKJOB performs the same function, but allows changes.</p>
DSPJOBDB	X	X	<p>The OUTPUT keyword value has changed from *LIST to *PRINT in the OS/400 program.</p>
DSPJOBLOG	X	X	<p>The OUTPUT keyword value has changed from *LIST to *PRINT in the OS/400 program.</p>
DSPJOBQ	X	WRKJOBQ	<p>The command name has been changed to WRK, but the function is the same in the OS/400 program. The OUTPUT keyword value has changed from *LIST to *PRINT in the OS/400 program.</p>
DSPJRN	X	X	<p>The OUTPUT keyword value has changed from *LIST to *PRINT in the OS/400 program. OUTPUT(*NONE) in the System/38 environment is changed to OUTPUT(*OUTFILE) in the OS/400 program. The OUTFILE value *NONE is not supported in the OS/400 program.</p>
DSPJRNA	X	WRKJRNA	<p>The command name has been changed to WRK, but the function is the same in the OS/400 program. The OUTPUT keyword value has changed from *LIST to *PRINT in the OS/400 program.</p>
DSPJRNMNU	X	WRKJRN	<p>The command name has been changed to WRK, but the function is the same in the OS/400 program.</p>
DSPJRNRCVA	X	X	<p>The OUTPUT keyword value has changed from *LIST to *PRINT in the OS/400 program.</p>
DSPKBDMAP	X	X	
DSPLIB	X	X	<p>The OUTPUT keyword value has changed from *LIST to *PRINT in the OS/400 program.</p>
DSPLIBL	X	X	<p>The OUTPUT keyword value has changed from *LIST to *PRINT in the OS/400 program.</p>
DSPLIND	X	X	<p>The OUTPUT keyword value has changed from *LIST to *PRINT in the OS/400 program.</p>

Figure A-1 (Page 22 of 39). System/38 Commands

System/38 Command	System/38 Environment Run	OS/400 New Command	Comments
DSPLINSTS	X	WRKCFGSTS	The WRKCFGSTS command replaces DSPLINSTS. The function is the same in the OS/400 program except for the OUTPUT parameter is not supported.
DSPLNKSTS			The X.25 status information is not available on the AS/400 system.
DSPLOG	X	X	The OUTPUT keyword value has changed from *LIST to *PRINT in the OS/400 program. The DSPLOG command does not support the QCHG or QSRV log. See "Logs" on page 2-18.
DSPMNU		GO	The DSPMNU command has been primarily replaced with the GO command and the CMDxxx menus. Only the OS/400 commands appear on menus. See "Menu" on page 2-18.
DSPMODSTS	X	X	The OUTPUT keyword value has changed from *LIST to *PRINT in the OS/400 program.
DSPMSG	X	X	The OUTPUT keyword value has changed from *LIST to *PRINT in the OS/400 program. The default for DSPMSG is to display both the work station message queue (if any messages exist) and the user message queue. The OS/400 command supports the new values *WRKUSR and *SYSOPR for the MSGQ parameter.
DSPMSGD	X	X	The OUTPUT keyword value has changed from *LIST to *PRINT in the OS/400 program. The MSGID keyword is dropped from the OS/400 program. The MSGF keyword defaults to QCPFMSG in the OS/400 program. The DETAIL keyword is added in the OS/400 program. In the OS/400 program, the MSGID parameter has been dropped and *ALL is an added value for the RANGE parameter.
DSPMSGF	X	WRKMSGF	The OUTPUT keyword is not supported. The OS/400 command, WRKMSGD, has QCPFMSG as the default. It supports more options than the System/38 environment DSPMSGF command, which required the user to specify a message file name.
DSPNETA	X	X	See the discussion on "Network Attributes" on page 2-22. The alert network attributes have significantly changed. Some new attributes can only be accessed from OS/400 commands. The OUTPUT keyword value has changed from *LIST to *PRINT in the OS/400 program.
DSPNETF	X	WRKNETF	The command name has been changed to WRK, but the function is the same in the OS/400 program. The OUTPUT keyword value has changed from *LIST to *PRINT in the OS/400 program. The OUTPUT value of *NONE is specified as *OUTFILE on the OS/400 command.
DSPNETJOBE	X	WRKNETJOBE	The command name has been changed to WRK, but the function is the same in the OS/400 program. The OUTPUT keyword value has changed from *LIST to *PRINT in the OS/400 program.

Figure A-1 (Page 23 of 39). System/38 Commands

System/38 Command	System/38 Environment Run	OS/400 New Command	Comments
DSPOBJAUT	X	X	<p>The OUTPUT keyword value has changed from *LIST to *PRINT in the OS/400 program.</p> <p>New values for object types (for example, *MENU) are valid with the OS/400 command. The new values are not valid for the System/38 environment command.</p> <p>In the OS/400 program, the DSP commands perform display functions only. The EDTOBJAUT command must be used to make changes.</p> <p>For the OS/400 program, outfile support is added.</p>
DSPOBJD	X	X	<p>The OUTPUT value of *LIST is specified as *PRINT on the OS/400 command.</p> <p>The OUTPUT value of *NONE is specified as *OUTFILE on the OS/400 command. This prevents both the display and outfile support on the same command as exists in the System/38 environment.</p> <p>New values for object types (for example, *MENU) are valid with the OS/400 command. The new values are not valid for the System/38 environment command. If a OBJTYPE(*ALL) is specified, the new object types are displayed.</p> <p>In the OS/400 program, the DSP commands perform display functions only. The WRKOBJ command must be used to make changes.</p> <p>The OS/400 command supports a new option on the OUTMBR parameter to allow you to control whether the member should be added to or replaced. The System/38 environment command implicitly does a replace.</p> <p>The library qualifier for OBJ is *LIBL.</p> <p>In the System/38 environment, the *PRTIMG object type, if specified, is not supported. It exists to allow for source to be moved to a System/38. In the OS/400 program, the *PRTIMG object type cannot be specified.</p>
DSPOBJLCK	X	WRKOBJLCK	<p>The command name has been changed to WRK, but the function is the same in the OS/400 program. The OUTPUT keyword value has changed from *LIST to *PRINT in the OS/400 program.</p> <p>New values for object types (for example, *MENU) are valid with the OS/400 command. The new values are not valid for the System/38 environment command.</p>
DSPOUTQ	X	WRKOUTQ	<p>The command name has been changed to WRK, but the function is the same in the OS/400 program. The OUTPUT keyword value has changed from *LIST to *PRINT in the OS/400 program.</p>
DSPOUTQD	X	WRKOUTQD	<p>The command name has been changed to WRK, but the function is the same in the OS/400 program. The OUTPUT keyword value has changed from *LIST to *PRINT in the OS/400 program.</p>
DSPOVR	X	X	<p>For the OS/400 program, the INVNBR parameter has been renamed to LVL and parameter value of *CURRENT has changed to *.</p> <p>The OUTPUT keyword value has changed from *LIST to *PRINT in the OS/400 program.</p>
DSPPGM	X	X	<p>The OUTPUT keyword value has changed from *LIST to *PRINT in the OS/400 program.</p>

Figure A-1 (Page 24 of 39). System/38 Commands

System/38 Command	System/38 Environment Run	OS/400 New Command	Comments
DSPPGMADP	X	X	The OUTPUT keyword value has changed from *LIST to *PRINT in the OS/400 program. The OUTPUT value of *NONE is specified as *OUTFILE on the OS/400 command. The OUTFILE value *NONE is not supported in the OS/400 program.
DSPPGMCHG		DSPPTF	The new parameter OUTFILE is supported. The OUTPUT value of *LIST is changed to *PRINT in the OS/400 program. The new parameter OUTMBR is supported in the OS/400 program. The LIB parameter is not supported in the OS/400 program. The PGMID parameter changes to LICPGM in the OS/400 program.
DSPPGMMNU	X	STRPGMMNU	The LOGRQS parameter is ignored in the System/38 environment and logging always occurs. The JOBID parameter defaults to *USRPRF. For other changes in the menu operation, see the "Programmer Menu" on page 2-27.
DSPPGMREF	X	X	The OUTPUT keyword value has changed from *LIST to *PRINT in the OS/400 program. The OUTPUT value of *NONE is specified as *OUTFILE on the OS/400 command. The OUTFILE value *NONE is not supported in the OS/400 program. The OS/400 command supports a new option on the OUTMBR parameter to allow you to control whether the member should be added to or replaced. The System/38 environment command implicitly does a replace. A default of *LIBL is used for the OS/400 program instead of *USRLIBL as in the System/38 environment.
DSPPGMVAR	X	X	The OUTPUT keyword value has changed from *LIST to *PRINT in the OS/400 program. For the OS/400 program, the INVLVL parameter is renamed to RCRLVL.
DSPRCDLCK	X	X	The OUTPUT keyword value has changed from *LIST to *PRINT in the OS/400 program.
DSPRDR	X	WRKRDR	The command name has been changed to WRK, but the function is the same in the OS/400 program. The OUTPUT keyword value has changed from *LIST to *PRINT in the OS/400 program.
DSPRJECFG	X	X	The OUTPUT keyword value has changed from *LIST to *PRINT in the OS/400 program.
DSPRJESSN	X	WRKRJESSN	The command name has been changed to WRK, but the function is the same in the OS/400 program. The OUTPUT keyword value has changed from *LIST to *PRINT in the OS/400 program.
DSPRPYL	X	WRKRPYLE	The command name has been changed to WRK, but the function is the same in the OS/400 program. The OUTPUT keyword value has changed from *LIST to *PRINT in the OS/400 program.
DSPSAVF	X	X	The OUTPUT keyword value has changed from *LIST to *PRINT in the OS/400 program.
DSPSBMJOB	X	WRKSBMJOB	The command name has been changed to WRK, but the function is the same in the OS/400 program. The OUTPUT keyword value has changed from *LIST to *PRINT in the OS/400 program. The default for the OS/400 command changes the default of SBMFROM from *JOB to *USER.

Figure A-1 (Page 25 of 39). System/38 Commands

System/38 Command	System/38 Environment Run	OS/400 New Command	Comments
DSPSBS	X	WRKSBSJOB	The command name has been changed to WRK, but the function is the same in the OS/400 program. The OUTPUT keyword value has changed from *LIST to *PRINT in the OS/400 program.
DSPSBSD	X	X	The OUTPUT keyword value has changed from *LIST to *PRINT in the OS/400 program.
DSPSPLF	X	X	
DSPSPLFA	X	WRKSPLFA	The command name has been changed to WRK, but the function is the same in the OS/400 program. The OUTPUT keyword value has changed from *LIST to *PRINT in the OS/400 program.
DSPSRVSTS	X	X	
DSPSSND	X	WRKSSND	The command name has been changed to WRK, but the function is the same in the OS/400 program. The OUTPUT keyword value has changed from *LIST to *PRINT in the OS/400 program.
DSPSTGCFG			The display function is available through either DST or SST. See "Checksums" on page 2-2.
DSPSYS	X	WRKSBS	The command name has been changed to WRK, but the function is the same in the OS/400 program. The OUTPUT keyword value has changed from *LIST to *PRINT in the OS/400 program.
DSPSYSSTS	X	WRKSYSSTS	The command name has been changed to WRK, but the function is the same in the OS/400 program. The OUTPUT keyword value has changed from *LIST to *PRINT in the OS/400 program.
DSPSYSVAL	X	X	The OUTPUT keyword value has changed from *LIST to *PRINT in the OS/400 program. The list of system values has changed. Some System/38 values have been deleted, some have changed definitions, and new system values exist. Only the OS/400 commands can access the new system values. See "System Values" on page 2-56.
DSPPTAP	X	X	The OUTPUT keyword value has changed from *LIST to *PRINT in the OS/400 program.
DSPTRC	X	X	The OUTPUT keyword value has changed from *LIST to *PRINT in the OS/400 program.
DSPTRCDTA	X	X	The OUTPUT keyword value has changed from *LIST to *PRINT in the OS/400 program.
DSPUSRPRF	X	X	The OUTPUT keyword value has changed from *LIST to *PRINT in the OS/400 program. The DSPUSRPRF command exists in the OS/400 program, but does not have a function key to allow a change. The WRKUSRPRF command can be used for a similar function. New parameters are supported in the OS/400 program.
DSPUSRPWD			DSPUSRPWD is not supported on the AS/400 system as it is only meaningful when passwords are not encrypted. See "Security" on page 2-36.
DSPWTR	X	WRKWTR	The command name has been changed to WRK, but the function is the same in the OS/400 program. The OUTPUT keyword value has changed from *LIST to *PRINT in the OS/400 program. The OS/400 WRKWTR command supports the new keyword DSPFMT and the WTR parameter supports the new value *PRT.

Figure A-1 (Page 26 of 39). System/38 Commands

System/38 Command	System/38 Environment Run	OS/400 New Command	Comments																				
DUPDKT	X	X	<p>The TOLOC and FROMLOC parameters are ignored in the System/38 environment and not supported in the OS/400 command. FROMDEV, TODEV, and COPIES are new keywords in the OS/400 program. Only RGZVOL remains the same in both the OS/400 program and the System/38 environment. See "Diskette" on page 2-10 for a discussion of the need for a QDKT device description in the System/38 environment.</p> <p>The System/38 environment DEV parameter defaults to QDKT. The OS/400 DEV parameter requires a user-specified value.</p>																				
EDTDOC			<p>The EDTDOC command from System/38 does not run in the System/38 environment. A command of the same name in the OS/400 program exists to access the Office editor. See "Text Management 5714-WP2" on page 2-65 for how this command is supported.</p>																				
EDTIGCDCT	X	X																					
EDTIGCTBL	X	STRCGU																					
EDTSRC	X	STRSEU																					
EDTTXT	X		See "Text Management 5714-WP2" on page 2-65 for how this command is supported.																				
EJTEMLOUT	X	X	New parameters have been added to the OS/400 program for EMLLOC and PRTDEV.																				
ELSE	X	X																					
EMLPRTKEY	X	X	New parameters have been added to the OS/400 program for EMLLOC and PRTDEV.																				
EML3270	X	STREML3270	<p>The KBDTYP entries have changed for the OS/400 program. See "Emulation (3270)" on page 2-11. The following keyword names have changed:</p> <table border="0"> <thead> <tr> <th>System/38 Environment</th> <th>OS/400 Keywords</th> </tr> </thead> <tbody> <tr> <td>EMLCTLU</td> <td>EMLCTL</td> </tr> <tr> <td>WAITHOST</td> <td>INZWAIT</td> </tr> <tr> <td>KBDTYP</td> <td>KBDTYPE</td> </tr> <tr> <td>ROLLUP</td> <td>PAGEDOWN</td> </tr> <tr> <td>ROLLDOWN</td> <td>PAGEUP</td> </tr> <tr> <td>WRKSTN</td> <td>DSPDEV</td> </tr> </tbody> </table> <p>The PAGEDOWN and PAGEUP keyword values *PF1 through *PF24 have changed to *F1 through *F24 in the OS/400 program.</p> <p>The System/38 environment EML3270 command has been changed. The values BLB, SFB, and SGB will not be accepted for the KBDTYP parameter. The values are removed for the following keyboards:</p> <table border="0"> <tbody> <tr> <td>BLB</td> <td>Belgium country specific code page</td> </tr> <tr> <td>SFB</td> <td>Swiss/French country specific code page</td> </tr> <tr> <td>SGB</td> <td>Swiss/German country specific code page</td> </tr> </tbody> </table>	System/38 Environment	OS/400 Keywords	EMLCTLU	EMLCTL	WAITHOST	INZWAIT	KBDTYP	KBDTYPE	ROLLUP	PAGEDOWN	ROLLDOWN	PAGEUP	WRKSTN	DSPDEV	BLB	Belgium country specific code page	SFB	Swiss/French country specific code page	SGB	Swiss/German country specific code page
System/38 Environment	OS/400 Keywords																						
EMLCTLU	EMLCTL																						
WAITHOST	INZWAIT																						
KBDTYP	KBDTYPE																						
ROLLUP	PAGEDOWN																						
ROLLDOWN	PAGEUP																						
WRKSTN	DSPDEV																						
BLB	Belgium country specific code page																						
SFB	Swiss/French country specific code page																						
SGB	Swiss/German country specific code page																						
ENCCPHK	X	X																					
ENCFRMMSTK	X	X	<p>The cryptographic parameter names have changed as follows:</p> <table border="0"> <thead> <tr> <th>System/38 Environment</th> <th>OS/400 Keywords</th> </tr> </thead> <tbody> <tr> <td>XDMNK1</td> <td>CRSDMNK1</td> </tr> <tr> <td>XDMNK2</td> <td>CRSDMNK2</td> </tr> </tbody> </table>	System/38 Environment	OS/400 Keywords	XDMNK1	CRSDMNK1	XDMNK2	CRSDMNK2														
System/38 Environment	OS/400 Keywords																						
XDMNK1	CRSDMNK1																						
XDMNK2	CRSDMNK2																						

Figure A-1 (Page 27 of 39). System/38 Commands

System/38 Command	System/38 Environment Run	OS/400 New Command	Comments						
ENCTOMSTK	X	X	The cryptographic parameter names have changed as follows: <table border="0"> <tr> <td>System/38 Environment</td> <td>OS/400 Keywords</td> </tr> <tr> <td>XDMNK</td> <td>CRSDMNK</td> </tr> </table>	System/38 Environment	OS/400 Keywords	XDMNK	CRSDMNK		
System/38 Environment	OS/400 Keywords								
XDMNK	CRSDMNK								
ENDCBLDBG	X	X							
ENDCMTCTL	X	X							
ENDDBG	X	X							
ENDDO	X	X							
ENDINP	X	X							
ENDJOB	X	ENDBCHJOB	If ENDJOB is specified in the OS/400 program, the System/38 CNLJOB function is used. For the OS/400 command ENDBCHJOB, the parameter ADLINTJOBS is supported.						
ENDJRNP	X	X							
ENDJRNP	X	X							
ENDPASTHR	X	X							
ENDPGM	X	X							
ENDSRV	X	ENDSRVJOB							
ENTADM			Administrative management is not supported on the AS/400 system.						
ENTBGU	X	STRBGU							
ENTCBLDBG	X	STRCBLDBG							
ENTDBG	X	STRDBG	The user must have *CHANGE authority to debug a program instead of the read right on System/38.						
ENTPS	X	STROFC							
EXCBASPRC	X	STRBASPRC							
FMTDTA	X	X	For the OS/400 program, the OPTION parameter supports a new value to select if second-level message text should be printed. In the OS/400 program, the default library qualifier has changed to CURLIB.						
FMTRJEDTA	X	CVTRJEDTA							
GENCPHK	X	X	The cryptographic parameter names have changed as follows: <table border="0"> <tr> <td>System/38 Environment</td> <td>OS/400 Keywords</td> </tr> <tr> <td>SNDXDMNK</td> <td>SNDCRSDMNK</td> </tr> <tr> <td>RCVXDMNK</td> <td>RCVCRSDMNK</td> </tr> </table>	System/38 Environment	OS/400 Keywords	SNDXDMNK	SNDCRSDMNK	RCVXDMNK	RCVCRSDMNK
System/38 Environment	OS/400 Keywords								
SNDXDMNK	SNDCRSDMNK								
RCVXDMNK	RCVCRSDMNK								
GENMAC	X	X							
GENPIN	X	X							
GENXDMNK	X	GENCRSDMNK	The cryptographic parameter names have changed as follows: <table border="0"> <tr> <td>System/38 Environment</td> <td>OS/400 Keywords</td> </tr> <tr> <td>XDMNK</td> <td>CRSDMNK</td> </tr> </table>	System/38 Environment	OS/400 Keywords	XDMNK	CRSDMNK		
System/38 Environment	OS/400 Keywords								
XDMNK	CRSDMNK								
GOTO	X	X							
GRTACCAUT	X	X							
GRTDOCAUT		GRTUSRPMN							

Figure A-1 (Page 28 of 39). System/38 Commands

System/38 Command	System/38 Environment Run	OS/400 New Command	Comments
GRTOBJAUT	X	X	<p>New values for object types (for example, *MENU) are valid with the OS/400 command. The new values are not valid for the System/38 environment command.</p> <p>For the OS/400 program, the AUTL parameter is added.</p> <p>For the OS/400 program, new values exist for the AUT parameter. See "Security" on page 2-36.</p> <p>In the System/38 environment, the *PRTIMG object type, if specified, is not supported. It exists to allow for source to be moved to System/38. In the OS/400 program, the *PRTIMG object type cannot be specified.</p>
GRTUSRAUT	X	X	
HLDCMNDEV	X	X	
HLDJOB	X	X	
HLDJOBQ	X	X	
HLDOUQT	X	X	
HLDRDR	X	X	
HLDSPLF	X	X	The SELECT parameter has been added and FILE(*SELECT) is supported in the OS/400 program.
HLDWTR	X	X	
IF	X	X	
INZDKT	X	X	<p>The LOC parameter is ignored in the System/38 environment and not supported in the OS/400 command. See "Diskette" on page 2-10 for a discussion of the need for a QDKT device description in the System/38 environment.</p> <p>The System/38 environment DEV parameter defaults to QDKT. The OS/400 DEV parameter requires a user-specified value. The SUFFIX parameter is not supported in the OS/400 program.</p>
INZPFM	X	X	
INZTAP	X	X	The tape densities allowed on the System/38 are supported in the System/38 environment. In the OS/400 program, the default is *DEVTYPE and the AS/400 densities are supported.
JOB	X	BCHJOB	<p>There is a difference between System/38 and the System/38 environment with the RTGDTA parameter. On System/38 the default is *JOB. In the System/38 environment, the default is QCMD38. In the OS/400 program, the default is QCMD8.</p> <p>The OS/400 BCHJOB command supports the new keywords for PRTDEV, DATFMT, and DATSEP. The CNLSEV parameter name has been changed to ENDSEV. The OUTQ parameter supports the new values of *DEV and *USRPRF.</p>
JRNAP	X	STRJRNAP	
JRNPF	X	STRJRNPF	
LODPGMCHG		LODPTF	The VOL and LOC parameters are not supported. The DEV parameter is now used to specify the media type that is used to load the PTFs. The PTF can be on tape or diskette, in a save file, or received electronically. The PGMID parameter is changed to LICPGM in the OS/400 program. The LIB parameter is not supported in the OS/400 program.
LSTCMDUSG	X	PRTCMDUSG	

Figure A-1 (Page 29 of 39). System/38 Commands

System/38 Command	System/38 Environment Run	OS/400 New Command	Comments
LSTCNPDTA			The CSNAP function does not exist on the AS/400 system. Some of the same function may be achieved by the device configuration THRESHOLD parameter.
LSTCNPST			The CSNAP function does not exist on the AS/400 system. Some of the same function may be achieved by the device configuration THRESHOLD parameter.
LSTERRLOG		PRTERRLOG	The function is replaced by the PRTERRLOG command. It is similar to LSTERRLOG, but supports additional parameters ERRLOGID and RSRCNAME. The TYPE parameter value *VSDR changes to *VOLSTAT in the OS/400 program. The VSDR parameter changes to VOLSTAT in the OS/400 program.
LSTINTDTA	X	PRTINTDTA	The function TYPE(*ECLOG) is not supported. TYPE(*MTR) has changed to TYPE(*INTCFG) in the OS/400 program.
MNGDEVTBL	X	WRKDEVTBL	
MNGDIR		WRKDIR	Additional parameters are supported on the WRKDIR and WRKDSTL commands.
MNGDSTL		WRKDSTL	Additional parameters are supported on the WRKDIR and WRKDSTL commands.
MNGPGMTBL	X	WRKPGMTBL	
MNGUSRTBL	X	WRKUSRTBL	
MONMSG	X	X	
MOVOBJ	X	X	New values for object types (for example, *MENU) are valid with the OS/400 command. The new values are not valid for the System/38 environment command. In the System/38 environment, the *PRTIMG object type, if specified, is not supported. It exists to allow for source to be moved to System/38. In the OS/400 program, the *PRTIMG object type cannot be specified.
MRGFORMD	X	X	
MRGMSGF	X	X	
OPNDBF	X	X	
OPNQRYF	X	X	The OS/400 command supports the new function %DIGITS. For the OS/400 program, the new parameter IGNDDECERR is supported. A new value *LAST is supported for the member part of the FILE parameter.
OVRBSCF	X		Mixed, communications, and BSC files are replaced in the OS/400 program by ICF files. See "Data Description Specifications (DDS)" on page 4-4.
OVRCMNF	X		Mixed, communications, and BSC files are replaced in the OS/400 program by ICF files. See "Data Description Specifications (DDS)" on page 4-4.
OVRCRDF			Card devices are not supported on the AS/400 system.
OVRDBF	X	X	The OS/400 command supports the new values *FIRST and *LAST for the MBR parameter.
OVRDKTF	X	X	The LOC parameter is ignored in the System/38 environment and not supported in the OS/400 command. See "Diskette" on page 2-10 for a discussion of the need for a QDKT device description in the System/38 environment. For the OS/400 program, the OUTPTY and USRDTA parameters have been added.
OVRDSPF	X	X	

Figure A-1 (Page 30 of 39). System/38 Commands

System/38 Command	System/38 Environment Run	OS/400 New Command	Comments
OVRMSGF	X	X	
OVRMXDF	X		Mixed, communications, and BSC files are replaced in the OS/400 program by ICF files. See "Data Description Specifications (DDS)" on page 4-4.
OVRPRTF	X	X	<p>The parameters TRNTBL and PRTIMG are ignored for the System/38 environment command. The parameters are not supported on the OS/400 command.</p> <p>The System/38 parameter FORMSIZE is renamed PAGESIZE on the OS/400 commands.</p> <p>For OS/400 commands, the following parameter changes have also occurred:</p> <ul style="list-style-type: none"> • DEV supports the new values *SYSVAL and *JOB. *NONE is not allowed. • PRTQLTY supports the new value *DEVD. • FONT supports the new value *CPI. • COPIES supports up to 255 copies (instead of 99). • New values are supported for the CPI, IGCCPI, and LPI parameters for DBCS printers only. • File supports the new value *PRTF. <p>For the OS/400 program, the new parameters SPLFNAME, OUTPTY, JUSTIFY, and USRDTA have been added.</p> <p>A new parameter, DUPLEX, has been added in the OS/400 program.</p> <p>For the OS/400 program, the System/38 DRAWER(3) value is replaced by DRAWER(*E1), and DRAWER(3) is used to select the third paper drawer.</p>
OVRSAVF	X	X	
OVRTAPF	X	X	<p>For the OS/400 program, the EXTEND parameter is a list. The second element supports *CHECK and *NOCHECK.</p> <p>For the OS/400 program, SEQNBR/ supports the new value *NEXT.</p>
PCHPGM			The PCHPGM command is not supported. PTFs are used.
PGM	X	X	
PRPAPAR		CRTAPAR	<p>The INCMTR parameter function is supported as the INTCFG parameter on the OS/400 command. The LOC parameter is not supported in the OS/400 program and is ignored in the System/38 environment.</p> <p>The OS/400 command CRTAPAR has significant differences in function and keywords. The keywords used are dependent on the reported problem.</p>
PRTDOC			The PRTDOC command from System/38 does not run in the System/38 environment. A command of the same name in the OS/400 program exists to access the Office editor. See "Text Management 5714-WP2" on page 2-65 for how this command is supported by a PRPQ.
PWRCTLU			The PWR commands for controllers and devices are not supported by the AS/400 system.
PWRDEV			The PWR commands for controllers and devices are not supported by the AS/400 system.

Figure A-1 (Page 31 of 39). System/38 Commands

System/38 Command	System/38 Environment Run	OS/400 New Command	Comments
PWRDWNSYS	X	X	The PWRDWNSYS command ADRRGN and CFGSTG parameters are ignored on the System/38 environment command and are not supported on the OS/400 command. Address regeneration is done at IPL time on the AS/400 system. The disk device configuration function is done through DST. For the OS/400 command, the DELAY parameter default is changed from *NOLIMIT to 3600 (1 hour).
QRYDTA	X		The System/38 Query product is only supported in the System/38 environment. See "Query" on page 4-16.
RCLDDMCNV	X	X	
RCLRSC	X	X	
RCLSTG	X	X	
RCVDTAARA	X		The RCVDTAARA command is not supported in the OS/400 program. You must convert to RTVDTAARA.
RCVF	X	X	
RCVJRNE	X	X	
RCVMSG	X	X	The PDPCODE parameter is ignored in the System/38 environment and not supported in the OS/400 program. The SECLVL keyword supports up to 3000 characters in the OS/400 program (1435 in the System/38 environment). Both the System/38 environment and the OS/400 program allow special control characters to be entered into the message text to assist in formatting.
RCVNETF	X	X	
RETURN	X	X	
RGZPFM	X	X	
RLSCMNDEV	X	X	
RLSJOB	X	X	
RLSJOBQ	X	X	
RLSOUTQ	X	X	
RLSRDR	X	X	
RLSSPLF	X	X	For the OS/400 program, the SELECT parameter is added and FILE(*SELECT) is supported.
RLSWTR	X	X	
RMVACC	X	X	
RMVAJE	X	X	
RMVBKP	X	X	
RMVBSCDEVE	X		Mixed, communications, and BSC files are replaced in the OS/400 program by ICF files. See "Data Description Specifications (DDS)" on page 4-4.
RMVCMNDEVE	X		Mixed, communications, and BSC files are replaced in the OS/400 program by ICF files. See "Data Description Specifications (DDS)" on page 4-4.
RMVCMNE	X	X	The DEV parameter is changed in the System/38 environment. The OS/400 program adds the RMTLOCNAME parameter.
RMVDEVMODE			The device mode function has changed. There is a new object type for device modes. See "Device Configuration" on page 2-7.
RMVDSPDEVE	X		Mixed, communications, and BSC files are replaced in the OS/400 program by ICF files. See "Data Description Specifications (DDS)" on page 4-4.

Figure A-1 (Page 32 of 39). System/38 Commands

System/38 Command	System/38 Environment Run	OS/400 New Command	Comments				
RMVFCTE	X	X					
RMVJOBQE	X	X					
RMVJRNCHG	X	X					
RMVLIBLE	X	X					
RMVM	X	X					
RMVMSG	X	X					
RMVMSGD	X	X					
RMVNETJOBE	X	X					
RMVPGM	X	X					
RMVPGMCHG		RMVPTF	The PGMID parameter has changed to LICPGM and is required. PGM is no longer supported. The LIB keyword is not supported in the OS/400 program.				
RMVRJECMNE	X	X					
RMVRJERDRE	X	X					
RMVRJEWTRE	X	X					
RMVRPYLE	X	X					
RMVRTGE	X	X					
RMVTRC	X	X					
RMVWSE	X	X					
RMVXDMNK	X	RMVCRSDMNK	The cryptographic parameter names have changed as follows: <table border="0"> <tr> <td>System/38 Environment</td> <td>OS/400 Keywords</td> </tr> <tr> <td>XDMNK</td> <td>CRSDMNK</td> </tr> </table>	System/38 Environment	OS/400 Keywords	XDMNK	CRSDMNK
System/38 Environment	OS/400 Keywords						
XDMNK	CRSDMNK						
RNMDKT	X	X	The LOC parameter is ignored in the System/38 environment and not supported in the OS/400 command. The VOL parameter does not support the *LOC value in the OS/400 program. See "Diskette" on page 2-10 for a discussion of the need for a QDKT device description in the System/38 environment. The System/38 environment DEV parameter defaults to QDKT. The OS/400 DEV parameter requires a user-specified value. The SUFFIX parameter is not supported in the OS/400 program.				
RNMM	X	X					
RNMOBJ	X	X	New values for object types (for example, *MENU) are valid with the OS/400 command. The new values are not valid for the System/38 environment command. For the OS/400 program, the SYSTEM parameter is added to designate the location of the system. In the System/38 environment, the *PRTIMG object type, if specified, is not supported. It exists to allow for source to be moved to System/38. In the OS/400 program, the *PRTIMG object type cannot be specified.				
ROLLBACK	X	X					
RPLLIBL	X	CHGLIBL	The RPLLIBL command is unchanged in the System/38 environment. The OS/400 CHGLIBL command is the same as RPLLIBL plus the CURLIB parameter. The EDTLIBL command also exists in the OS/400 program to allow an easy interactive method of changing the library list.				
RRTJOB	X	X					
RSMBKP	X	X					

Figure A-1 (Page 33 of 39). System/38 Commands

System/38 Command	System/38 Environment Run	OS/400 New Command	Comments
RSMCTRLCY	X	X	For the OS/400 program, the CTLU keyword has been renamed to CTL.
RSMDEVRCY	X	X	
RSMLINRCY	X	X	
RSTAUT	X	X	
RSTDOC		RSTDLO	<p>Documents are still stored in the object type *DOC. Because of the new object type for folder (*FLR), some commands that worked only on documents now work on both documents and folders.</p> <p>The DOC parameter changes to DLO in the OS/400 program. The abbreviation DLO means <i>document library object</i> and covers both types. The OUTPUT parameter value *LIST changes to *PRINT in the OS/400 program. The NAMOPT parameter changes to NEWOBJ in the OS/400 program. The LOC parameter is not supported in the OS/400 program.</p> <p>For OS/400 commands, the LABEL parameter may be used to specify the data file identifier on the media.</p> <p>In the OS/400 program, VOL(*MOUNTED) is the default and DEV is a required parameter. DEV(*SAVF) should be used when restoring from a save file.</p> <p>The OVERRIDE command is supported in the OS/400 program.</p>
RSTLIB	X	X	<p>The LOC parameter is ignored in the System/38 environment and not supported in the OS/400 command.</p> <p>The OUTPUT keyword value has changed from *LIST to *PRINT in the OS/400 program.</p> <p>For OS/400 commands, the LABEL parameter may be used to specify the data file identifier on the media.</p> <p>In the OS/400 program, VOL(*MOUNTED) is the default and DEV is a required parameter. DEV(*SAVF) should be used when restoring from a save file.</p> <p>The ALWOBJDIF parameter is supported in the OS/400 program.</p>
RSTOBJ	X	X	<p>The LOC parameter is ignored in the System/38 environment and not supported in the OS/400 command.</p> <p>The OUTPUT keyword value has changed from *LIST to *PRINT in the OS/400 program.</p> <p>New values for object types (for example, *MENU) are valid with the OS/400 command. The new values are not valid for the System/38 environment command.</p> <p>The OS/400 command supports the FILEMBR parameter to restore individual members.</p> <p>For OS/400 commands, the LABEL parameter may be used to specify the data file identifier on the media.</p> <p>The ALWOBJDIF parameter is supported in the OS/400 program.</p> <p>In the OS/400 program, VOL(*MOUNTED) is the default and DEV is the required parameter. DEV(*SAVF) should be used when restoring from a save file.</p> <p>In the System/38 environment, the *PRTIMG object type, if specified, is not supported. It exists to allow for source to be moved to System/38. In the OS/400 program, the *PRTIMG object type cannot be specified.</p>

Figure A-1 (Page 34 of 39). System/38 Commands

System/38 Command	System/38 Environment Run	OS/400 New Command	Comments
RSTPGMPRD		RSTLICPGM	The OUTPUT keyword value has changed from *LIST to *PRINT in the OS/400 program. The LOC parameter is not supported in the OS/400 program. The RSTPGMPRD command does not run in the System/38 environment. The OS/400 command supports tape only and has significant changes. The <i>CL Reference</i> contains additional information.
RSTUSRPRF	X	X	The LOC parameter is ignored in the System/38 environment and not supported in the OS/400 commands. DEV is a required parameter in the OS/400 program. The ALWOBJDIF parameter and MAIL keyword are supported in the OS/400 program.
RTVCLSRC	X	X	
RTVDFUSRC	X		The System/38 DFU product is only supported in the System/38 environment. See "Data File Utility (DFU)" on page 4-16.
RTVDTAARA	X	X	The DTAARA keyword supports the new option *ADT.
RTVGRPA	X	X	
RTVJOBA	X	X	For the OS/400 program, new parameters exist for DATFMT, DATSEP, CURLIB, PRTDEV, SYSLIBL, CURUSER, and SUBTYPE. The EXCPTY parameter is renamed to RUNPTY. The CNLSTS keyword changes to ENDSTS in the OS/400 program.
RTVJRNE	X	X	
RTVMSG	X	X	The PDPCODE parameter is ignored in the System/38 environment and not supported in the OS/400 program. The ALRID keyword has been renamed to ALROPT in the OS/400 program. The values have changed for this keyword in both the System/38 environment and the OS/400 program. The SECLVL keyword supports up to 3000 characters in the OS/400 program (1435 in the System/38 environment). Both the System/38 environment and the OS/400 program allow special control characters to be entered into the message text to assist in formatting.
RTVNETA	X	X	See the discussion on "Network Attributes" on page 2-22. The alert network attributes have significantly changed. There are new attributes that can only be accessed from the OS/400 command. The SYSNAM parameter becomes SYSNAME in the OS/400 program.
RTVQRYSRC	X		The System/38 Query product is only supported in the System/38 environment. See "Query" on page 4-16.
RTVSYVAL	X	X	The list of system values has changed. Some System/38 values have been deleted, some have changed definitions and new system values exist. Only the OS/400 command can access the new system values. See "System Values" on page 2-56 and the <i>Work Management Guide</i> for more details about system values. The parameter SYSVAL(QAUTOIMPL) changes to SYSVAL(QIPLSTS) in the OS/400 program.
RTVUSRPRF	X	X	There are new keywords and values with the OS/400 command. See "Security" on page 2-36. New parameters are supported in the OS/400 program.
RVKACCAUT	X	X	
RVKDOCAUT		RVKUSRPMN	

Figure A-1 (Page 35 of 39). System/38 Commands

System/38 Command	System/38 Environment Run	OS/400 New Command	Comments
RVKOBJAUT	X	X	<p>New values for object types (for example, *MENU) are valid with the OS/400 command. The new values are not valid for the System/38 environment command.</p> <p>In the System/38 environment, the *PRTIMG object type, if specified, is not supported. It exists to allow for source to be moved to System/38. In the OS/400 program, the *PRTIMG object type cannot be specified.</p> <p>For the OS/400 program, new values exist for the AUT parameter. See "Security" on page 2-36.</p> <p>The AUT parameter value *NORMAL changes to *CHANGE and the value *OPER changes to *USE in the OS/400 program.</p> <p>For the OS/400 program, the AUTL parameter is added.</p>
SAVCHGOBJ	X	X	<p>The LOC parameter is ignored in the System/38 environment and not supported in the OS/400 command.</p> <p>New values for object types (for example, *MENU) are valid with the OS/400 command. The new values are not valid for the System/38 environment command.</p> <p>For the OS/400 command, the LABEL parameter may be used to specify the data file identifier on the media.</p> <p>DEV is a required parameter. DEV(*SAVF) should be specified when saving to a save file.</p> <p>In the System/38 environment, the *PRTIMG object type, if specified, is not supported. It exists to allow for source to be moved to System/38. In the OS/400 program, the *PRTIMG object type cannot be specified.</p> <p>In the OS/400 program, the new parameter TGTRLS is supported.</p> <p>The CLEAR parameter value *YES changes to *ALL in the OS/400 program. The CLEAR parameter *NO changes to *NONE in the OS/400 program.</p>
SAVDOC		SAVDLO	<p>Documents are still stored in the object type *DOC. Because of the new object type for folder (*FLR), some commands that worked only on documents now work on both documents and folders.</p> <p>The LOC parameter is not supported in the OS/400 program.</p> <p>The OUTPUT parameter value *LIST changes to *PRINT in the OS/400 program.</p> <p>The DOC parameter becomes DLO and *SYSOBJNAM in the OS/400 program. The abbreviation DLO means <i>document library object</i> and covers both types.</p> <p>The PERIOD parameter becomes CRTDATE in the OS/400 program.</p> <p>The CLEAR parameter values *YES and *NO are not supported in the OS/400 program.</p> <p>For the OS/400 command, the LABEL parameter may be used to specify the data file identifier on the media.</p> <p>In the OS/400 program, DEV is a required parameter. DEV(*SAVF) should be specified when saving to a save file.</p> <p>In the OS/400 program, the new parameter TGTRLS is supported.</p> <p>In the OS/400 program, the *MAIL special value is supported on the DLO keyword.</p>

Figure A-1 (Page 36 of 39). System/38 Commands

System/38 Command	System/38 Environment Run	OS/400 New Command	Comments
SAVLIB	X	X	<p>The LOC parameter is ignored in the System/38 environment and not supported in the OS/400 command. See "Diskette" on page 2-10 for a discussion of the need for a QDKT device description in the System/38 environment.</p> <p>For the OS/400 command, the LABEL parameter may be used to specify the data file identifier on the media.</p> <p>In the OS/400 program, DEV is a required parameter. DEV(*SAVF) should be specified when saving to a save file.</p> <p>In the OS/400 program, the new parameter TGTRLS is supported.</p> <p>The CLEAR parameter value *YES changes to *ALL in the OS/400 program. The CLEAR parameter *NO changes to *NONE in the OS/400 program.</p>
SAVOBJ	X	X	<p>The LOC parameter is ignored in the System/38 environment and not supported in the OS/400 command.</p> <p>New values for object types (for example, *MENU) are valid with the OS/400 command. The new values are not valid for the System/38 environment command.</p> <p>In the System/38 environment, the *PRTIMG object type, if specified, is not supported. It exists to allow for source to be moved to System/38. In the OS/400 program, the *PRTIMG object type cannot be specified.</p> <p>The OS/400 command supports the FILEMBR parameter to save individual members.</p> <p>For the OS/400 command, the LABEL parameter may be used to specify the data file identifier on the media.</p> <p>In the OS/400 program, DEV is a required parameter. DEV(*SAVF) should be used when saving to a save file.</p> <p>The CLEAR parameter value *YES changes to *ALL in the OS/400 program. The CLEAR parameter *NO changes to *NONE in the OS/400 program.</p> <p>In the OS/400 program, the new parameter TGTRLS is supported.</p>
SAVSAVFDTA	X	X	<p>The LOC parameter is ignored in the System/38 environment and not supported in the OS/400 command.</p> <p>In the OS/400 program, DEV is a required parameter. DEV(*SAVF) should be used when saving to a save file.</p> <p>The DTACPR parameter is supported in the OS/400 program.</p>
SAVSYS	X	X	<p>SAVSYS only outputs to tape on the AS/400 system. The LOC parameter is ignored in the System/38 environment and not supported in the OS/400 command.</p> <p>In the OS/400 program, DEV is a required parameter.</p> <p>The CLEAR parameter value *YES changes to *ALL in the OS/400 program. The CLEAR parameter *NO changes to *NONE in the OS/400 program.</p>
SBMCRDJOB			Card devices are not supported on the AS/400 system.
SBMDBJOB	X	X	
SBMDKTJOB	X	X	The LOC parameter is ignored in the System/38 environment and not supported in the OS/400 command. See "Diskette" on page 2-10 for a discussion of the need for a QDKT device description in the System/38 environment.
SBMFNCJOB	X	X	

Figure A-1 (Page 37 of 39). System/38 Commands

System/38 Command	System/38 Environment Run	OS/400 New Command	Comments																					
SBMJOB	X	X	The defaults for the SBJOB command are changing as follows for the OS/400 command: <table border="1"> <thead> <tr> <th>Keyword</th> <th>System/38 Environment Default</th> <th>OS/400 Program Default</th> </tr> </thead> <tbody> <tr> <td>JOB</td> <td>QBATCH.QGPL</td> <td>*USRPRF</td> </tr> <tr> <td>RTGDTA</td> <td>*JOB</td> <td>QCMB</td> </tr> <tr> <td>INLLIBL</td> <td>*JOB</td> <td>*CURRENT</td> </tr> <tr> <td>OUTQ</td> <td>*JOB</td> <td>*CURRENT</td> </tr> <tr> <td>HSGQ</td> <td>*WRKSTN</td> <td>*USRPRF</td> </tr> <tr> <td>RQSDTA</td> <td>*JOB</td> <td>*CMD</td> </tr> </tbody> </table> <p>For the OS/400 program, there are new parameters for CURLIB, SYSLIBL, and PRTDEV.</p> <p>There is a difference between System/38 and the System/38 environment with the RTGDTA parameter. On System/38 the default is *JOB. In the System/38 environment, the default is QCMD38.</p>	Keyword	System/38 Environment Default	OS/400 Program Default	JOB	QBATCH.QGPL	*USRPRF	RTGDTA	*JOB	QCMB	INLLIBL	*JOB	*CURRENT	OUTQ	*JOB	*CURRENT	HSGQ	*WRKSTN	*USRPRF	RQSDTA	*JOB	*CMD
Keyword	System/38 Environment Default	OS/400 Program Default																						
JOB	QBATCH.QGPL	*USRPRF																						
RTGDTA	*JOB	QCMB																						
INLLIBL	*JOB	*CURRENT																						
OUTQ	*JOB	*CURRENT																						
HSGQ	*WRKSTN	*USRPRF																						
RQSDTA	*JOB	*CMD																						
SBMNETJOB	X	X																						
SBMRJEJOB	X	X																						
SBMRMTCMD	X	X																						
SETATNPGM	X	X																						
SETMSTK	X	X																						
SIGNOFF	X	X																						
SNDBRKMSG	X	X	For the OS/400 program, the SNDBRKMSG TOMSGQ parameter is a required entry. *ALLWS is still supported, but must be specified. The System/38 environment version defaults to *ALLWS.																					
SNDDTAARA	X		The SNDDTAARA command is not supported in the OS/400 program. You must convert to CHGDTAARA.																					
SNDF	X	X																						
SNDJRNE	X	X																						
SNDMSG	X	X	The OS/400 command supports the new parameter TOUSR for the user message queue. This also allows an option to send to all active (signed on) work stations.																					
SNDNETF	X	X																						
SNDNETMSG	X	X																						
SNDNETSPLF	X	X																						
SNDPGMMSG	X	X	The OS/400 command supports the new parameter TOUSR for the user message queue. This also allows an option to send to all active (signed on) work stations.																					
SNDRCVF	X	X																						
SNDRPY	X	X																						
SNDUSRMSG	X	X	The OS/400 command supports the new parameter TOUSR for the user message queue. This also allows an option to send to all active (signed on) work stations.																					
SRVJOB	X	STRSRVJOB																						
STPCTLR	X	ENDCTLR	For the OS/400 program, the CTLU keyword has been renamed to CTL.																					
STPDEVRCY	X	ENDDEVRCY																						
STPLINRCY	X	ENDLINRCY																						
STRCNFCHK			Use the ANZPRB command if you are experiencing problems.																					
STRCRDRDR			Card devices are not supported on the AS/400 system.																					

Figure A-1 (Page 38 of 39). System/38 Commands

System/38 Command	System/38 Environment Run	OS/400 New Command	Comments
STRCRDWTR			Card devices are not supported on the AS/400 system.
STRDBRDR	X	X	
STRDKTRDR	X	X	The LOC parameter is ignored in the System/38 environment and not supported in the OS/400 command. See "Diskette" on page 2-10 for a discussion of the need for a QDKT device description in the System/38 environment.
STRDKTWTR	X	X	The LOC parameter is ignored in the System/38 environment and not supported in the OS/400 command. See "Diskette" on page 2-10 for a discussion of the need for a QDKT device description in the System/38 environment. For the OS/400 program, the AUTOTRM parameter is renamed to AUTOEND.
STRPDP			The problem determination functions have changed. See "Service" on page 2-44. Use the ANZPRB command if you are experiencing problems.
STRPRTEML	X	X	The STRPRTEML command in the OS/400 program supports new parameters for EMLLOC, PRTDEV, DFRPRTOUT, NUMCOL, NUMLIN, SPOOL, and TRNTBLOUTB. The CHRSET keyword values have changed in both the System/38 environment and the OS/400 program as described in "Emulation (3270)" on page 2-11. The EMLCTLU parameter changes to EMLCTL in the OS/400 program. The MSGQ parameter value *WRKSTN changes to *DSPDEV in the OS/400 program. The System/38 environment STRPRTEML command has been changed. The values BLB, SFB, and SGB will not be accepted for the CHRSET parameter. The values are removed for the following keyboards: BLB Belgium country specific code page SFB Swiss/French country specific code page SGB Swiss/German country specific code page
STRPRTWTR	X	X	The OS/400 command supports new keywords FILESEP and ALIGN. New keyword and values are supported for DEV(*ALL), DEV(*SYSVAL), FORMTYPE(*FORMS) and OUTQ(*DEV). The AUTOTRM keyword has been renamed to AUTOEND. For the OS/400 program, WTR(*ALL) and WTR(*SYSVAL) are added.
STRRJCSL	X	X	
STRRJERDR	X	X	
STRRJESSN	X	X	
STRRJEWTR	X	X	
STRSBS	X	X	
TFRBCHJOB	X	X	
TFRCTL	X	X	
TFRGRPJOB	X	X	
TFRJOB	X	X	
TFRSECJOB	X	X	

Figure A-1 (Page 39 of 39). System/38 Commands

System/38 Command	System/38 Environment Run	OS/400 New Command	Comments
TRCINT	X	X	The LOC parameter is ignored in the System/38 environment and not supported in the OS/400 command. See "Diskette" on page 2-10 for a discussion of the need for a QDKT device description in the System/38 environment. The SET parameter value *CNL has been changed to *END in the OS/400 program. For the OS/400 program, the new parameter SIZE is supported.
TRCJOB	X	X	The OUTPUT keyword value changes from *LIST to *PRINT in the OS/400 program. The SET parameter value *CNL changes to *END in the OS/400 program. The OUTPUT value of *NONE is specified as *OUTFILE on the OS/400 command. The OUTFILE parameter value *NONE is not supported in the OS/400 program.
TRMCPF	X	ENDSYS	
TRMGRPJOB	X	ENDGRPJOB	
TRMPRTEML	X	ENDPRTEML	New parameters have been added to the OS/400 program for EMLLOC and PRTDEV.
TRMRJESSN	X	ENDRJESSN	
TRMSBS	X	ENDSBS	
TRNPIN	X	X	
VFYMSTK	X	X	
VFYPIN	X	X	
VFYPRT	X	X	
VRYCTLU	X	VRYCFG	The VRYCFG command renames the CTLU keyword to CFGOBJ and supports a list of 256, instead of 50, names. New parameters exist for CFGTYPE, RESET, and RANGE. RESET is not valid on System/38 environment VRYCTLU.
VRYDEV	X	VRYCFG	The VRYCFG command renames the DEV keyword to CFGOBJ and supports a list of 256, instead of 50, names. New parameters exist for CFGTYPE, RESET, and RANGE. RESET is not valid on System/38 environment VRYDEV.
VRYLIN	X	VRYCFG	The VRYCFG command renames the LINE keyword to CFGOBJ and supports a list of 256, instead of 50, names. New parameters exist for CFGTYPE, RESET, and RANGE. RESET is not valid on System/38 environment VRYLIN.
WAIT	X	X	

Appendix B. DDS Keyword Changes

The following DDS keyword restrictions apply to both the System/38 environment and the OS/400 program:

- In a physical file, a logical file cannot be specified on the FORMAT keyword. See "Data Description Specifications (DDS)" on page 2-6 for more information about the FORMAT keyword.
- On the SECURITY keyword, the *PASSWORD special value is not allowed for the password parameter. Also, the maximum length of the security information is reduced from 11 to 10 characters.
- On the DSPSIZ keyword, the values associated with the 16 by 64 (*DS1) and the 12 by 80 (*DS2) displays are not valid. See "Data Description Specifications (DDS)" on page 2-6 for more information about the DSPSIZ keyword.

The following routing keywords exist in the System/38 environment, but not in the OS/400 program:

RTGAID
RTGCON
RTGDEV
RTGDEVCLS
RTGFIRST
RTGFLD
RTGFMT
RTGPOS

The information returned on the RTGDEV, RTGDEVCLS, and RTGFMT keywords is available in the Common I/O Feedback Area (offsets 32, 30, and 20, respectively). The information returned on the RTGAID keyword is available either in the Device Dependent I/O Feedback Area (offset 2) or through the use of response indicators specified on the associated DDS keywords. See Appendix A in the *Data Management Guide* for more information on the I/O Feedback areas. Because the RTGCON, RTGFIRST, RTGFLD, and RTGPOS keywords were used only to pass data and constants to a routing program, they have no use on the AS/400 system.

To convert DDS source to the OS/400 program, you must convert qualified names to the OS/400

syntax of LIBRARY/OBJECT. The following keywords that exist on System/38 allow the specification of a qualified name to be specified as a parameter value:

ALTSEQ
ERRMSGID
EVOKE
FORMAT
JFILE
JOIN
JREF

MSGCON
PFILE
PRINT
REF
REFFLD
SFLMSGID
TRNTBL

The REFFLD keyword that exists on System/38 allows the specification of a qualified field name. On the OS/400 program, the syntax of a qualified field name is RECORD/FIELD

On the OS/400 program, two keywords have been renamed, with no change in function:

System/38 Environment	OS/400 Program
RCVCFM	RCVCONFIRM
TRNRND	RCVTRNRND

The ACCPTH keyword has been replaced by the REFACPTH keyword in the OS/400 program. On the System/38, the ACCPTH keyword described explicit access path sharing. The ACCPTH keyword in the System/38 environment and the REFACPTH keyword in the OS/400 program are only used to copy the key, select, and omit specifications and the values for the DYNSTL, FIFO, LIFO, FCFO, UNIQUE, and ALTSEQ keywords to the logical file being created. See "Database" on page 2-5 for more information about these keywords.

In database files, the new DBCS data types of J (DBCS Only) and E (DBCS Either) are supported in the OS/400 program. They are not allowed in the System/38 environment. The REFSHIFT keyword cannot be specified on a DBCS capable field on the OS/400 program, but is allowed on a DBCS Open field in the System/38 environment.

See "Database" on page 2-5 for more information about DBCS fields.

In printer files, the DRAWER(3) keyword has a different meaning in the System/38 environment and in the OS/400 program. To select forms from the envelope drawer, specify DRAWER(3) in the System/38 environment or DRAWER(*E1) in the OS/400 program. The special value *E1 is not supported on the DRAWER keyword in the System/38 environment. In the OS/400 program, the DRAWER(3) keyword is used to select cut sheets from the third paper drawer.

The following enhancements are allowed in the System/38 environment but are not valid on a System/38:

- Hexadecimal message identifiers are allowed on the DDS message keywords.
- The OS/400 database keyword FIFO is allowed, although a warning message is issued when the file is created. See "Database" on page 2-5 for more information about this keyword.
- In a logical file, DBCS capable fields can be specified on the CONCAT keyword. See

"Database" on page 2-5 for more information about DBCS.

- In a display file, a field can start in the first position of the display when SLNO(*VAR) is specified on the record.
- In a display file, a field can end in the last position of the display.
- In a display file on a DBCS system, file and record level CHGINPDFT(FE) keywords apply to DBCS Only, Open, and Either fields.
- In a display file on a DBCS system, file and record level CHGINPDFT(LC) keywords apply to DBCS Open and DBCS Either fields. Also, the LOWER, CHECK(LC), and CHGINPDFT(LC) keywords apply to an IGCALTTYP field when IGCDDTA(*YES) is specified. This function allows entry of lowercase alphameric characters in fields which, on the System/38, allowed entry of only double-byte, uppercase alphameric, and Katakana characters.
- In a printer file, the CHRISZ keyword can be specified in the same record format with BLKFOLD, CPI, and DFNCHR keywords.

Appendix C. Display and Print File Return Codes

The following describes the list of all return codes used for display and print files. Most of the return codes have changed.

If you have coded for these return codes in your high-level language program, you need to make changes to successfully migrate to the System/38 environment.

The return codes used on the AS/400 system for display and print files are identical between the System/38 environment and the OS/400 program. Once you are successfully operating in the System/38 environment, no changes are needed in the return code processing to convert to the OS/400 program.

Note: The 02 major return code is new and indicates that your job is being requested to be ended by a command such as ENDJOB or ENDSBS. The 02 return code does not cause an escape message to the high-level language program.

Major and Minor Return Codes Summary (Display and Printer)

Figure C-1 (Page 1 of 6). Return Codes

System/38	AS/400 System	Message	DSP	PRT
0000	0000	-----	x	x
0000	0000	CPF4019	x	
0000	0000	CPF4032		x
0000	0000	CPF4033		x
0000	0000	CPF4054	x	
0000	0000	CPF4056		x
0000	0000	CPF4057		x
0000	0000	CPF4082	x	
0000	0000	CPF4410	x	
0000	0000	CPF4420		x
0000	0000	CPF4421		x
0000	0000	CPF4905		x
0000	0000	CPF4913		x
0000	0000	CPF4914		x
0000	0000	CPF4916		x
0000	0000	CPF4918		x

Figure C-1 (Page 1 of 6). Return Codes

System/38	AS/400 System	Message	DSP	PRT
0000	0000	CPF4919		x
0000	0000	CPF5003	x	
0000	0200	-----	x	
0001	0001	-----	x	
0300	0300	-----	x	
0300	0300	CPF5037	x	
0309	0309	CPF4741	x	
0310	0310	CPF4742	x	
0310	0310	CPF4743	x	
0400	0412	CPF4737	x	
0400	0412	CPF5044	x	
0401	8319	-----	x	
0402	80EB	CPF4062	x	
0402	831D	CPF4912	x	
0402	831D	CPF5002	x	
0402	831D	CPF5012	x	
0402	831D	CPF5014	x	
0402	831D	CPF5021	x	
0402	831E	CPF5005	x	
0402	831E	CPF5039	x	
0402	831E	CPF5045	x	
0402	831F	CPF5117	x	
0402	83E0	CPF5053	x	
0402	83E0	CPF5054	x	
0402	83E0	CPF5186		x
0402	83E0	CPF5187		x
0402	83F6	CPF5216	x	
0403	0000	CPA4073		x
0403	0000	CPA4074		x
0403	0000	CPA4075		x
0403	0000	CPA4076		x
0403	3431	CPF5062	x	
0403	80EB	CPF4219		x
0403	80EB	CPF4637		x
0403	8181	CPF4725	x	
0403	830B	CPF5217	x	
0403	831E	CPF5056	x	
0403	831E	CPF5059	x	

Figure C-1 (Page 2 of 6). Return Codes

System/38	AS/400 System	Message	DSP	PRT
0403	831F	CPF5048	x	
0403	831F	CPF5160		x
0403	8322	CPF5060	x	
0403	83F6	CPF4591		x
0403	83F6	CPF4634		x
0403	83F6	CPF4636		x
0403	83F6	CPF5063	x	
0403	83F6	CPF5075		x
0403	83F6	CPF5215		x
0403	83F6	CPF5216	x	
0403	83F6	CPF5234		x
0403	83F6	CPF5261		x
0403	83F6	CPF5364		x
0403	83F6	CPF5369		x
0405	831D	CPF5008	x	
0405	831E	CPF5011	x	
0405	831E	CPF5051	x	
0405	8322	CPF5013	x	
0405	832D	CPF5052	x	
0411	831F	CPF4906		x
0412	831D	CPF4909		x
0414	0000	CPA4072		x
0414	8082	CPF5116		x
0414	8343	CPF5043	x	
0415	831E	CPF4915		x
0416	80EB	CPF4191	x	
0416	831D	CPD4016		x
0416	831D	CPD4017		x
0416	831D	CPF5108		x
0416	831D	CPF5273		x
0416	831D	CPF5275		x
0416	831D	CPF5276		x
0416	831D	CPF5288		x
0416	831D	CPF5289		x
0416	831D	CPF5302	x	
0416	831D	CPF5303	x	
0416	831D	CPF5324		x
0416	831D	CPF5359		x
0416	831D	CPF5363		x
0416	831E	CPD4015		x

Figure C-1 (Page 2 of 6). Return Codes

System/38	AS/400 System	Message	DSP	PRT
0416	831E	CPD4018		x
0416	831E	CPF5055	x	
0416	831E	CPF5245		x
0416	831E	CPF5290		x
0416	831E	CPF5320		x
0416	831E	CPF5321		x
0416	831E	CPF5322		x
0416	831E	CPF5323		x
0416	831E	CPF5325		x
0416	831E	CPF5362		x
0416	83F6	CPD4014		x
0416	83F6	CPF5297		x
0417	831E	CPF5185		x
0418	8343	CPF5004		x
0423	831E	CPF5066	x	
0800	0800	CPD4077	x	
0800	0800	CPF50A0	x	
1100	1100	CPF4740	x	
3400	3431	-----	x	
3400	831E	CPF5055	x	
3400	831F	CPF4010	x	
3400	831F	CPF4078	x	
3401	8197	CPF5047	x	
3401	8319	CPF4158		x
3401	8319	CPF4531		x
3401	8319	CPF5050	x	x
3402	0300	CPF5020	x	
3402	831E	CPF5045	x	
3402	83E0	CPF5022	x	
3402	83E0	CPF5023	x	
3402	83E0	CPF5053	x	
3402	83E0	CPF5054	x	
3402	83F6	CPF5216	x	
3402	83F6	CPF5301	x	
3420	831E	CPF5049	x	
3420	831E	CPF5056	x	
3421	0300	CPF5017	x	
3421	8322	CPF5013	x	
3421	83E8	CPF4910	x	
3422	832D	CPF5052	x	

Figure C-1 (Page 3 of 6). Return Codes

System/38	AS/400 System	Message	DSP	PRT
8000	0000	CPA4251		x
8000	80B3	CPF4128		x
8000	80B3	CPF9808		x
8000	80EB	CPD4012		x
8000	80EB	CPD4013		x
8000	80EB	CPD4020		x
8000	80EB	CPD4021		x
8000	80EB	CPD4024		x
8000	80EB	CPD4025		x
8000	80EB	CPD4033		x
8000	80EB	CPD4034		x
8000	80EB	CPD4036		x
8000	80EB	CPD4037		x
8000	80EB	CPD4038		x
8000	80EB	CPF4129	x	
8000	80EB	CPF4133		x
8000	80EB	CPF4138		x
8000	80EB	CPF4139		x
8000	80EB	CPF4142		x
8000	80EB	CPF4143		x
8000	80EB	CPF4148	x	x
8000	80EB	CPF4156	x	x
8000	80EB	CPF4157		x
8000	80EB	CPF4159		x
8000	80EB	CPF4162		x
8000	80EB	CPF4169	x	
8000	80EB	CPF4181		x
8000	80EB	CPF4196		x
8000	80EB	CPF4206		x
8000	80EB	CPF4209		x
8000	80EB	CPF4214		x
8000	80EB	CPF4217		x
8000	80EB	CPF4222		x
8000	80EB	CPF4224		x
8000	80EB	CPF4237		x
8000	80EB	CPF4238	x	x
8000	80EB	CPF4263		x
8000	80EB	CPF4264		x
8000	80EB	CPF4295		x
8000	80EB	CPF4296		x

Figure C-1 (Page 3 of 6). Return Codes

System/38	AS/400 System	Message	DSP	PRT
8000	80EB	CPF4335		x
8000	80EB	CPF4336		x
8000	80EB	CPF4337		x
8000	80EB	CPF4338		x
8000	80EB	CPF4339		x
8000	80EB	CPF4340		x
8000	80EB	CPF4352		x
8000	80ED	CPF4131	x	x
8000	8282	CPF4171	x	
8000	82AA	CPF4103	x	x
8000	82B3	CPF4130	x	
8000	82EE	CPF4105	x	x
8000	830B	CPF5070	x	x
8000	831D	CPD4027		x
8000	831D	CPD4028		x
8000	831D	CPD4029		x
8000	831D	CPD4030		x
8000	831D	CPD4041		x
8000	831D	CPF5148		x
8000	831D	CPF5366		x
8000	831D	CPF5367		x
8000	831D	CPF5368		x
8000	831E	CPD4031		x
8000	83F6	CPD4022		x
8000	83F6	CPD4026		x
8000	83F6	CPD4035		x
8001	8181	CPF5507		x
8001	82A6	CPF4527		x
8001	82A6	CPF5103		x
8001	83F6	CPF4516		x
8001	83F6	CPF5246		x
8001	8181	CPF5254	x	
8001	8191	CPF4551	x	
8001	8197	CPF4192		x
8001	8197	CPF4216		x
8001	8197	CPF4533	x	x
8001	8197	CPF4583		x
8001	8197	CPF5143		x
8001	8197	CPF5268		x
8001	8281	CPF4168	x	x

Figure C-1 (Page 4 of 6). Return Codes

System/38	AS/400 System	Message	DSP	PRT
8001	8282	CPF4354	x	
8001	83F6	CPF4190		x
8002	8081	CPF4182	x	x
8002	8081	CPF4510	x	x
8002	8081	CPF5192	x	
8002	8081	CPF5196		x
8002	8081	CPF5257	x	x
8002	8081	CPF5257	x	x
8002	8081	CPF5262		x
8002	8081	CPF5401		x
8002	8081	CPF5403	x	
8002	8081	CPF5404	x	
8002	8081	CPF5405	x	
8002	8081	CPF5408	x	x
8002	8081	CPF5409	x	x
8002	8081	CPF5410	x	x
8002	8081	CPF5411	x	x
8002	8081	CPF5414	x	
8002	8081	CPF5416	x	x
8002	8081	CPF5418	x	x
8002	8081	CPF5423	x	x
8002	8081	CPF5429	x	x
8002	8081	CPF5431	x	x
8002	8081	CPF5433	x	x
8002	8081	CPF5434	x	x
8002	8081	CPF5441	x	
8002	8081	CPF5447	x	x
8002	8081	CPF5456	x	
8002	8081	CPF5507	x	
8002	8082	CPF4354	x	
8002	80A6	CPF4527	x	
8002	80C0	CPF5412	x	x
8002	80C0	CPF5413	x	x
8002	80C0	CPF5419	x	x
8002	80C0	CPF5420	x	x
8002	80C0	CPF5421	x	
8002	80C0	CPF5430	x	
8002	80F8	CPF5427	x	x
8002	81C2	CPF5170	x	
8002	81C2	CPF5422	x	

Figure C-1 (Page 4 of 6). Return Codes

System/38	AS/400 System	Message	DSP	PRT
8002	8281	CPF4182	x	
8002	8281	CPF5257		x
8002	8281	CPF5424	x	
8002	82A6	CPF4190	x	
8002	82A6	CPF5453		x
8004	8291	CPF4179	x	x
8005	8082	CPF5269		x
8005	8282	CPF4298		x
8101	0000	CPD4069		x
8101	8081	CPF5414	x	x
8101	8082	CPF4502		x
8101	80A6	CPF4527	x	
8101	80B3	CPF4128	x	x
8101	80C0	CPF4262		x
8101	80C0	CPF4509		x
8101	80C0	CPF5103	x	
8101	80C0	CPF5192	x	
8101	80C0	CPF5247		x
8101	80C0	CPF5439	x	
8101	80EB	CPF4163	x	
8101	80EB	CPF4345	x	x
8101	80EF	CPF4104	x	x
8101	80EF	CPF5279	x	
8101	80F8	CPF4132	x	x
8101	80F8	CPF4213	x	
8101	80F8	CPF4550	x	
8101	80F8	CPF5129	x	x
8101	80F8	CPF5263	x	
8101	8181	CPF4289		x
8101	8181	CPF4552		x
8101	8181	CPF4553	x	x
8101	8181	CPF5105	x	x
8101	8181	CPF5159		x
8101	8181	CPF5189	x	
8101	8197	CPF4197	x	x
8101	8197	CPF4524	x	x
8101	8197	CPF4533	x	x
8101	8197	CPF5106	x	x
8101	8197	CPF5143	x	x
8101	8197	CPF5201		x

Figure C-1 (Page 5 of 6). Return Codes

System/38	AS/400 System	Message	DSP	PRT
8101	8281	CPF4221	x	x
8101	8282	CPF4110		x
8101	8291	CPF4193	x	
8101	8291	CPF4291	x	x
8101	82A6	CPF4124	x	x
8101	82A6	CPF4190	x	x
8101	82A6	CPF4527		x
8101	82A6	CPF5103		x
8101	82AB	CPF4285	x	
8101	82B3	CPF4106		x
8101	82B3	CPF4109	x	
8101	82B3	CPF4282	x	
8101	82EF	CPF4104	x	x
8101	82EF	CPF4186	x	x
8101	82F0	CPF4324	x	
8101	831D	CPF5218	x	
8101	831E	CPF4564	x	
8101	831E	CPF5149	x	
8101	831E	CPF5179	x	
8101	83F8	CPF5293	x	x
8102	8081	CPF5415	x	
8102	8081	CPF5455	x	
8102	8082	CPF5269	x	
8102	80A6	CPF4527	x	
8102	80C0	CPF5103	x	x
8102	80C0	CPF5437	x	x
8102	80F8	CPF5144	x	
8102	8191	CPF4146		x
8102	8191	CPF4193		x
8102	8191	CPF4526	x	x
8102	8191	CPF4542	x	x
8102	8191	CPF5128	x	x
8102	8191	CPF5198	x	x
8102	8197	CPF4149	x	
8102	8197	CPF4192	x	x
8102	8197	CPF4197	x	x
8102	8197	CPF4524	x	x
8102	8197	CPF4533	x	x
8102	8197	CPF4538	x	x
8102	8197	CPF5106	x	x

Figure C-1 (Page 5 of 6). Return Codes

System/38	AS/400 System	Message	DSP	PRT
8102	8197	CPF5140	x	
8102	8197	CPF5143	x	x
8102	8197	CPF5199	x	x
8102	8197	CPA5201		x
8102	8197	CPF5360		x
8102	81C2	CPF5170	x	x
8102	81C2	CPF5422	x	x
8102	8281	CPF4168	x	
8102	8291	CPF4146	x	
8102	8291	CPF4193	x	
8102	8297	CPF4192	x	
8102	8297	CPF5047	x	
8102	82A6	CPF4124		x
8102	82A6	CPF4190	x	x
8102	82A6	CPF4527		x
8200	8281	CPF5254	x	
8200	8282	CPF5548	x	
8200	82EF	CPF5278	x	
8201	0000	CPF5508	x	
8201	8081	CPF5414	x	x
8201	80C0	CPF5439	x	
8201	80EB	CPF5151	x	
8201	80EB	CPF5552	x	
8201	80F8	CPF4132	x	
8201	80F8	CPF5129	x	x
8201	8197	CPF5265	x	
8201	8281	CPF4168	x	
8201	8281	CPF5105	x	
8201	8281	CPF5257	x	
8201	8291	CPF5260	x	
8201	8297	CPF5106	x	
8201	8297	CPF5143	x	
8201	82A6	CPF5103	x	
8201	82A6	CPF5517	x	
8201	82AB	CPF5333	x	
8201	82B3	CPF5217	x	
8201	82B3	CPF5332	x	
8201	82B3	CPF5355	x	
8201	82EF	CPF4104	x	x
8201	82EF	CPF5279	x	x

Figure C-1 (Page 6 of 6). Return Codes

System/38	AS/400 System	Message	DSP	PRT
8201	831E	CPF5149		x
8202	0000	CPF5508	x	
8202	8081	CPF5414	x	
8202	8081	CPF5415	x	
8202	80C0	CPF5437	x	x
8202	80EB	CPF5511	x	
8202	8191	CPF5128	x	
8202	81C2	CPF5170	x	
8202	8281	CPF5410	x	
8202	8281	CPF5411	x	
8202	8281	CPF5447	x	
8202	8281	CPF5455	x	
8202	8282	CPF4354	x	x
8202	8291	CPF5198	x	
8202	8297	CPF5106	x	
8202	8297	CPF5140	x	
8202	8297	CPF5143	x	
8202	8297	CPF5199	x	
8202	82A6	CPF4124	x	
8202	82A6	CPF5103	x	
8204	80EB	CPF5510	x	
8204	80EB	CPF5512	x	
8204	80EB	CPF5513	x	
8204	82A9	CPF4366	x	
8204	82A9	CPF5381	x	
8204	82AA	CPF4747	x	
8204	82EE	CPF4760	x	
8204	82EE	CPF5038	x	
8204	830B	CPF5068	x	
8206	8191	CPF5128	x	
8307	830B	CPF5067	x	
8308	830B	CPD4079	x	
8308	830B	CPF4739	x	
8308	830B	CPF5068	x	

Appendix D. Sample Programs

This appendix describes the Print Device Configuration Program and the Move Library Objects and Check Library Owner commands.

1. Print Device Configuration Program

The following CL program operates on System/38. The program prints a copy of the device configuration objects and copies the contents to a source member in a standard source file. This avoids the large number of pages that would normally be required to print all of the configuration details. Source entry utility (SEU) can then be used (for example, the scan capability) to find any specific configuration objects.

The program does not run in the System/38 environment as written due to changes in the con-

troller object type. However, a similar command is included in the QUSRTOOL library. See the tool PRTDEVCFG.

To use the program you must:

- Create a specific source file named DEVCFG. Because a large configuration results in many records, you should create the file with a large SIZE value:

```
CRTSRCPF  FILE(DEVCFG.xxxx)
           SIZE(50000 5000 10)
           TEXT('Source file for Device
Configuration')
ADDPFM    FILE(DEVCFG.xxxx)
           MBR(DEVCFG)
```

- Create the CL program PRTDEVCFGCL from the source shown.
- Submit a CALL command to the PRTDEVCFGCL program to batch.

The following is the CL source:

```

SEQNBR *... .. 1 ... .. 2 ... .. 3 ... .. 4 ... .. 5 ... .. 6 ... .. 7
 1.00 /* PRTDEVCFG - Prints device configuration - CPP for PRTDEVCFG */
 2.00      PGM
 3.00      DCLF1      QADSPOBJ
 4.00      CHKOBJ    OBJ(DEVCFG) OBJTYPE(*FILE) MBR(DEVCFG)
 5.00      CRTPF     DEVCFG.QTEMP RCDLEN(80)
 6.00      DSPOBJD   OBJ(*ALL.QSYS) OBJTYPE(*LIND) OUTPUT(*NONE) +
 7.00              OUTFILE(DSPOBJD.QTEMP)
 8.00      DSPOBJD   OBJ(*ALL.QSYS) OBJTYPE(*CUD) OUTPUT(*NONE) +
 9.00              OUTFILE(DSPOBJD2.QTEMP)
10.00      CPYF     FROMFILE(DSPOBJD2.QTEMP) +
11.00              TOFILE(DSPOBJD.QTEMP) MBROPT(*ADD)
12.00      DSPOBJD   OBJ(*ALL.QSYS) OBJTYPE(*DEVD) OUTPUT(*NONE) +
13.00              OUTFILE(DSPOBJD2.QTEMP)
14.00      CPYF     FROMFILE(DSPOBJD2.QTEMP) +
15.00              TOFILE(DSPOBJD.QTEMP) MBROPT(*ADD)
16.00      OVRDBF   QADSPOBJ TOFILE(DSPOBJD.QTEMP)
17.00      OVRPRTF  QPDCLINE HOLD(*YES)
18.00      OVRPRTF  QPDCCTLU HOLD(*YES)
19.00      OVRPRTF  QPDCDEVD HOLD(*YES)
20.00 READ:      RCVF      /* Read an object */
21.00      MONMSG   MSGID(CPF0864) EXEC(GOTO ENDPGM) /* EOF */
22.00      IF       (&ODOBTP *EQ '*LIND') DO /* Line */
23.00      DSPLIND   LIND(&ODOBNM) OUTPUT(*LIST)
24.00      CPYSPLF  FILE(QPDCLINE) TOFILE(DEVCFG.QTEMP) +
25.00              SPLNBR(*LAST) MBROPT(*ADD)
26.00      CNLSPLF  FILE(QPDCLINE)
27.00      ENDDO    /* Line */
28.00      IF       (&ODOBTP *EQ '*CUD ') DO /* Control unit */
29.00      DSPCUD    CUD(&ODOBNM) OUTPUT(*LIST)
30.00      CPYSPLF  FILE(QPDCCTLU) TOFILE(DEVCFG.QTEMP) +
31.00              SPLNBR(*LAST) MBROPT(*ADD)
32.00      CNLSPLF  FILE(QPDCCTLU)
33.00      ENDDO    /* Control unit */
34.00      IF       (&ODOBTP *EQ '*DEVD') DO /* Device */
35.00      DSPDEVD   DEVD(&ODOBNM) OUTPUT(*LIST)
36.00      CPYSPLF  FILE(QPDCDEVD) TOFILE(DEVCFG.QTEMP) +
37.00              SPLNBR(*LAST) MBROPT(*ADD)
38.00      CNLSPLF  FILE(QPDCDEVD)
39.00      ENDDO    /* Device */
40.00      GOTO     READ
41.00 ENDPGM:
42.00      CPYF     FROMFILE(DEVCFG) TOFILE(DEVCFG) +
43.00              MBROPT(*ADD) FMTOPT(*CVTSRC)
44.00      ENDPGM

```

2. Moving User Objects from One Library to Another

The Move Library Objects (MOVLIBOBJ) command moves some or all of the objects from one library to another. This is useful for mass migration of objects.

The typical command would be:

```
MOVLIBOBJ FROMLIB(xxx) TOLIB(yyy)
```

This command operates on either the System/38 or in the System/38 environment.

Some object types like *JRN and *JRNRCV cannot be moved. You must also be authorized to move an object.

At the completion of the command, a completion message is sent describing the number of objects moved, the number bypassed, and the number where failures (for example, not authorized) occurred.

Options exist on the command to move only:

- A specific object type (for example, *FILE).
- Generically named objects.
- Objects that start with a character other than Q. This can be of value when moving user objects from QGPL.

Combinations of specifications can be specified, such as move all the file objects beginning with ABC:

```
MOVLIBOBJ FROMLIB(xxx) TOLIB(yyy)  
OBJTYPE(*FILE) GENNAME(ABC)
```

To move all the objects from QGPL that do not start with Q you would specify:

```
MOVLIBOBJ FROMLIB(QGPL) TOLIB(yyy)  
EXCLUDE(*QNames)
```

The command supports the following parameters:

FROMLIB	The library to move from.
TOLIB	The library to move to.
OBJTYPE	The object type to move. The default is *ALL. Any object type that can be specified on MOV OBJ can be named.
GENNAME	A generic name. The default is *NONE. The generic name should be entered without an *.
EXCLUDE	Exclude object. The default is *NONE. *QNames can be entered to exclude any objects that begin with Q.

An OS/400 version of the command is also included in the QUSRTOOL library. See the tool MOVLIBOBJ.

To create the command, perform the following steps:

1. Enter the following command definition for the MOVLIBOBJ command.

```

1.00 /*PARMS PGM(MOVLIBOBJ) */
2.00 /* */
3.00 /* Moves objects from one library to another. Options exist to */
4.00 /* move only a generic name, only a specific type or those */
5.00 /* that do not begin with a Q. */
6.00 /* */
7.00 /* CPP is MOVLIBOBJ */
8.00 /* */
9.00 CMD PROMPT('Move Library Objects')
10.00 PARM KWD(FROMLIB) TYPE(*NAME) LEN(10) MIN(1) +
11.00 EXPR(*YES) PROMPT('From library:')
12.00 PARM KWD(TOLIB) TYPE(*NAME) LEN(10) MIN(1) +
13.00 EXPR(*YES) PROMPT('To library:')
14.00 PARM KWD(OBJTYPE) TYPE(*CHAR) LEN(8) DFT(*ALL) +
15.00 EXPR(*YES) RSTD(*YES) +
16.00 VALUES(*CHTFMT *CLS *CMD *DTAARA +
17.00 *DTAQ *FCT *FILE *GSS *JOBQ *JOBQ +
18.00 *MSGF *MSGQ *OUTQ *PGM *PRTIMG +
19.00 *SBSD *SPADCT *SSND *TBL *ALL) +
20.00 PROMPT('Object type:')
21.00 PARM KWD(GENNAME) TYPE(*NAME) LEN(10) DFT(*NONE) +
22.00 SPCVAL(*NONE) EXPR(*YES) +
23.00 PROMPT('Generic name (no *) or *NONE:')
24.00 PARM KWD(EXCLUDE) TYPE(*CHAR) LEN(10) DFT(*NONE) +
25.00 RSTD(*YES) EXPR(*YES) +
26.00 VALUES(*NONE *QNAMES) +
27.00 PROMPT('Exclude *NONE or *QNAMES:')

```

2. Create the MOVLIBOBJ command and specify:

```
PGM(MOVLIBOBJ)
```

3. Enter the source and create the CL program
MOVLIBOBJC.

```

1.00 /* Moves objects from one library to another - CPP for MOVLIBOBJC */
2.00      PGM      PARM(&FROMLIB &TOLIB &OBJTYPE &GENNAME +
3.00          &EXCLUDE)
4.00      DCLF     QADSPOBJ
5.00      DCL      &FROMLIB *CHAR LEN(10)
6.00      DCL      &TOLIB *CHAR LEN(10)
7.00      DCL      &OBJTYPE *CHAR LEN(8)
8.00      DCL      &GENNAME *CHAR LEN(10)
9.00      DCL      &EXCLUDE *CHAR LEN(10)
10.00     DCL      &GOODCNT *DEC LEN(5 0)
11.00     DCL      &BADCNT *DEC LEN(5 0)
12.00     DCL      &BYPCNT *DEC LEN(5 0)
13.00     DCL      &GOODCNTA *CHAR LEN(5)
14.00     DCL      &BADCNTA *CHAR LEN(5)
15.00     DCL      &BYPCNTA *CHAR LEN(5)
16.00     DCL      &GENCNT *DEC LEN(3 0) VALUE(10)
17.00     DCL      &GENCOMP *CHAR LEN(10)
18.00     DCL      &GENCOMP2 *CHAR LEN(10)
19.00     DCL      &TYPE *CHAR LEN(1)
20.00     DCL      &MSGID *CHAR LEN(7)
21.00     DCL      &MSGDTA *CHAR LEN(100)
22.00     DCL      &MSGF *CHAR LEN(10)
23.00     DCL      &MSGFLIB *CHAR LEN(10)
24.00     DCL      &ERRORSW *LGL
25.00     MONMSG   MSGID(CPF0000) EXEC(GOTO ERROR)
26.00     RTVJOBA  TYPE(&TYPE)
27.00     IF      (&TYPE *EQ '0') DO /* Batch job */
28.00          /* Ensure job log if in batch */
29.00     CHGJOB   LOG(4 0 *MSG)
30.00     ENDDO   /* Batch job */
31.00     IF      (&GENNAME *NE '*NONE') DO /* Generic name */
32.00     CHGVAR   &GENCOMP &GENNAME
33.00     GENLOOP: IF      (%SST(&GENNAME &GENCNT 1) *EQ ' ') DO /* Chr */
34.00     CHGVAR   &GENCNT (&GENCNT - 1)
35.00     GOTO    GENLOOP
36.00     ENDDO   /* Char exists */
37.00     ENDDO   /* Generic name */
38.00     DSPOBJD  OBJ(*ALL.&FROMLIB) OBJTYPE(*ALL) +
39.00          OUTPUT(*NONE) OUTFILE(DSPOBJP.QTEMP)
40.00     OVRDBF  QADSPOBJ TOFILE(DSPOBJP.QTEMP)
41.00     RMVMSG  CLEAR(*ALL)
42.00     READ:   RCVF   /* Read a record from DSPOBJD out file */
43.00     MONMSG  MSGID(CPF0864) EXEC(GOTO EOF)
44.00     IF      (&OBJTYPE *NE '*ALL') DO /* Not all types */
45.00     IF      (&ODOBTP *NE &OBJTYPE) DO /* Wrong type */
46.00     CHGVAR   &BYPCNT (&BYPCNT + 1)
47.00     GOTO    READ
48.00     ENDDO   /* Wrong type */
49.00     ENDDO   /* Not all types */
50.00     IF      (&GENNAME *NE '*NONE') DO /* Generic name */
51.00     CHGVAR   &GENCOMP2 %SST(&ODOBNM 1 &GENCNT) /* Gen len */
52.00     IF      (&GENCOMP *NE &GENCOMP2) DO /* Not gen val */
53.00     CHGVAR   &BYPCNT (&BYPCNT + 1)
54.00     GOTO    READ

```

```

55.00      ENDDO      /* Not generic value */
56.00      ENDDO      /* Generic name */
57.00      IF        (&EXCLUDE *EQ '*QNames') DO /* Exclude Qs */
58.00      IF        (%SST(&ODOBNM 1 1) *EQ 'Q') DO /* Q obj */
59.00      CHGVAR    &BYPCNT (&BYPCNT + 1)
60.00      GOTO      READ
61.00      ENDDO      /* Q obj */
62.00      ENDDO      /* Exclude Q names */
63.00      MOV OBJ   OBJ(&ODOBNM.&FROMLIB) OBJTYPE(&ODOBTP) +
64.00      TOLIB(&TOLIB)
65.00      MONMSG    MSGID(CPF0000) EXEC(DO) /* MOV OBJ failed */
66.00      /* Resend any messages */
67.00  OBJDIAG:  RCVMSG  MSGTYPE(*DIAG) MSGDTA(&MSGDTA) MSGID(&MSGID) +
68.00      MSGF(&MSGF) MSGFLIB(&MSGFLIB)
69.00      IF        (&MSGID *EQ '      ') GOTO OBJESCAPE
70.00      SNDPGMMSG  MSGID(&MSGID) MSGF(&MSGF.&MSGFLIB) +
71.00      MSGDTA(&MSGDTA) MSGTYPE(*DIAG)
72.00      GOTO      OBJDIAG /* Loop back for addl diagnostics */
73.00  OBJESCAPE:  RCVMSG  MSGTYPE(*EXCP) MSGDTA(&MSGDTA) MSGID(&MSGID) +
74.00      MSGF(&MSGF) MSGFLIB(&MSGFLIB)
75.00      SNDPGMMSG  MSGID(&MSGID) MSGF(&MSGF.&MSGFLIB) +
76.00      MSGDTA(&MSGDTA) MSGTYPE(*DIAG)
77.00      CHGVAR    &BADCNT (&BADCNT + 1)
78.00      GOTO      READ
79.00      ENDDO      /* MOV OBJ failed */
80.00      CHGVAR    &GOODCNT (&GOODCNT + 1) /* MOV OBJ successful */
81.00      GOTO      READ
82.00  EOF:        /* Send completion message with counts */
83.00      RCVMSG    MSGTYPE(*EXCP) /* Remove EOF from job log */
84.00      CHGVAR    &GOODCNTA &GOODCNT
85.00      CHGVAR    &BADCNTA &BADCNT
86.00      CHGVAR    &BYPCNTA &BYPCNT
87.00      SNDPGMMSG  MSG('Objs moved-' *CAT &GOODCNTA *CAT +
88.00      '      Objs bypassed-' *CAT &BYPCNTA *CAT +
89.00      '      Objs failed-' *CAT &BADCNTA) +
90.00      MSGTYPE(*COMP)
91.00      RETURN    /* Normal end of program */
92.00  ERROR:      /* Standard error handling routine */
93.00      IF        &ERRORSW SNDPGMMSG MSGID(CPF9999) +
94.00      MSGF(QCPFMSG) MSGTYPE(*ESCAPE) /* Func chk */
95.00      CHGVAR    &ERRORSW '1'
96.00  ERROR1:    RCVMSG  MSGTYPE(*DIAG) MSGDTA(&MSGDTA) MSGID(&MSGID) +
97.00      MSGF(&MSGF) MSGFLIB(&MSGFLIB)
98.00      IF        (&MSGID *EQ '      ') GOTO ESCAPE
99.00      SNDPGMMSG  MSGID(&MSGID) MSGF(&MSGF.&MSGFLIB) +
100.00      MSGDTA(&MSGDTA) MSGTYPE(*DIAG)
101.00      GOTO      ERROR1 /* Loop back for addl diagnostics */
102.00  ESCAPE:    RCVMSG  MSGTYPE(*EXCP) MSGDTA(&MSGDTA) MSGID(&MSGID) +
103.00      MSGF(&MSGF) MSGFLIB(&MSGFLIB)
104.00      SNDPGMMSG  MSGID(&MSGID) MSGF(&MSGF.&MSGFLIB) +
105.00      MSGDTA(&MSGDTA) MSGTYPE(*ESCAPE)
106.00      ENDPGM

```

3. Check for a Library Owner

The Check Library Owner (CHKLIBOWN) command checks the objects in a library and prints job log messages for all objects that are not owned by a specific owner. This is intended for those cases where:

- You are trying to ensure that all objects in a library are owned by the same user. A typical command would be:

```
CHKLIBOWN LIB(xxx) EXCLUDE(QPGMR)
```

You would receive a message for each object in the library that was not owned by QPGMR.

- You are trying to ensure that no user objects exist in QSYS. A special value *IBM is used in this case and you should submit the command as the security officer.

```
CHKLIBOWN LIB(QSYS) EXCLUDE(*IBM)
```

It is normal for some objects to appear in the job log that are not owned by QSYS such as message files used by high-level languages.

The completion message includes the number of objects bypassed and the number owned by other than the specified user.

This command operates on System/38 or in the System/38 environment.

The command supports the following parameters:

LIB	The library to be checked.
EXCLUDE	The owner name to be excluded. The special value *IBM may be used to bypass any IBM objects. This includes those objects marked as changed by the user or those owned by QSYS.

Objects such as *LIB and *LIND are always bypassed (only found in the QSYS library.)

The intent of this command is to check the libraries on System/38 before you migrate. However, the command does have general purpose usage, and on the OS/400 version is included in the QUSRTOOL library. See the tool CHKLIBOWN.

To create the command, perform the following steps:

1. Enter the following command definition for the CHKLIBOWN command.

```

SEQNBR *... .. 1 ... .. 2 ... .. 3 ... .. 4 ... .. 5 ... .. 6 ... .. 7
1.00 /*PARMS PGM(CHKLIBOWNC) */
2.00 /* */
3.00 /* Check Library owner checks all objects in a library to see */
4.00 /* if they are owned by the profile named. If not, a message */
5.00 /* is sent to the job log. The object types that are only in */
6.00 /* QSYS (eg *LIND) are bypassed. If the library is QSYS, */
7.00 /* message queue objects are bypassed if the name is the same */
8.00 /* as a device description. The special value *IBM excludes */
9.00 /* QSYS and other names beginning with Q except for QSECOFR, */
10.00 /* QPGMR, QCE, QPSR, and QSYSOPR. */
11.00 /* */
12.00 /* The CPP is CHKLIBOWNC */
13.00 /* */
14.00 CMD PROMPT('Check Library Owner')
15.00 PARM KWD(LIB) TYPE(*NAME) LEN(10) MIN(1) +
16.00 EXPR(*YES) +
17.00 PROMPT('Library to check:')
18.00 PARM KWD(EXCLUDE) TYPE(*NAME) LEN(10) MIN(1) +
19.00 EXPR(*YES) SPCVAL(*IBM) +
20.00 PROMPT('Exclude owner name or *IBM:')

```

2. Create the CHKLIBOWN command and specify:

```
PGM(CHKLIBOWNC)
```

3. Enter the source and create the CL program CHKLIBOWNC.

```

SEQNBR *... .. 1 ... .. 2 ... .. 3 ... .. 4 ... .. 5 ... .. 6 ... .. 7
1.00 /* CHKLIBOWNC - Check library owner - CPP for CHKLIBOWN */
2.00 PGM PARM(&LIB &EXCLUDE)
3.00 DCLF QADSPOBJ
4.00 DCL &LIB *CHAR LEN(10)
5.00 DCL &EXCLUDE *CHAR LEN(10)
6.00 DCL &OWNCNT *DEC LEN(5 0)
7.00 DCL &OWNCNTA *CHAR LEN(5)
8.00 DCL &OTHER *DEC LEN(5 0)
9.00 DCL &OTHERA *CHAR LEN(5)
10.00 DCL &BYPCNT *DEC LEN(5 0)
11.00 DCL &BYPCNTA *CHAR LEN(5)
12.00 DCL &TYPE *CHAR LEN(1)
13.00 RTVJOBA TYPE(&TYPE)
14.00 IF (&TYPE *EQ '0') DO /* Batch job */
15.00 /* Ensure job log if in batch */
16.00 CHGJOB LOG(4 0 *MSG)
17.00 ENDDO /* Batch job */
18.00 DSPOBJD OBJ(*ALL.&LIB) OBJTYPE(*ALL) DETAIL(*SERVICE) +
19.00 OUTPUT(*NONE) OUTFILE(DSPOBJP.QTEMP)
20.00 OVRDBF QADSPOBJ TOFILE(DSPOBJP.QTEMP)
21.00 RMVMSG CLEAR(*ALL)
22.00 LOOP: RCVF
23.00 MONMSG MSGID(CPF0864) EXEC(GOTO ENDPGM)
24.00 IF ((&ODOBTP *EQ '*LIB') *OR +
25.00 (&ODOBTP *EQ '*USRPRF') *OR +
26.00 (&ODOBTP *EQ '*LIND') *OR +
27.00 (&ODOBTP *EQ '*CTLD') *OR +
28.00 (&ODOBTP *EQ '*CUD') *OR +
29.00 (&ODOBTP *EQ '*DEVD')) DO /* Bypass */
30.00 CHGVAR &BYPCNT (&BYPCNT + 1)
31.00 GOTO LOOP
32.00 ENDDO /* Bypass */
33.00 IF (&ODOBOW *EQ &EXCLUDE) DO /* Owner excluded */
34.00 CHGVAR &OWNCNT (&OWNCNT + 1)
35.00 GOTO LOOP
36.00 ENDDO /* Owner excluded */
37.00 IF (&EXCLUDE *EQ '*IBM') DO /* EXCLUDE(*IBM) */
38.00 IF ((&ODUMOD *NE '1') *OR +
39.00 (&ODOBOW *EQ 'QSYS')) DO /* IBM obj/QSYS */
40.00 CHGVAR &OWNCNT (&OWNCNT + 1)
41.00 GOTO LOOP
42.00 ENDDO /* IBM object or owned by QSYS */
43.00 ENDDO /* OWNER(*IBM) */
44.00 CHKQSYS: IF ((&LIB *EQ 'QSYS') *AND +
45.00 (&ODOBTP *EQ '*MSGQ')) DO /* Chk WS MSGQ */
46.00 CHKOBJ OBJ(&ODOBNM.QSYS) OBJTYPE(*DEVD)
47.00 MONMSG MSGID(CPF9801) EXEC(GOTO RMVMSG) /* Not fnd */
48.00 CHGVAR &OWNCNT (&OWNCNT + 1)
49.00 GOTO LOOP
50.00 ENDDO /* Chk WS MSGQ */

```

```

51.00 RMVMSG:   RCVMSG      MSGTYPE(*EXCP) /* Remove from job log */
52.00          SNDPGMMSG  MSG('Object ' *CAT &ODOBNM *TCAT '.' *CAT +
53.00          &ODLBNM *TCAT ' type ' *CAT &ODOBTP *TCAT ' +
54.00          owned by ' *CAT &ODOBOW)
55.00          CHGVAR     &OTHER (&OTHER + 1)
56.00          GOTO      LOOP
57.00 ENDPGM:
58.00          RCVMSG      MSGTYPE(*EXCP) /* Remove EOF from job log */
59.00          CHGVAR     &OWNCNTA &OWNCNT
60.00          CHGVAR     &OTHERA &OTHER
61.00          CHGVAR     &BYPCNTA &BYPCNT
62.00          SNDPGMMSG  MSG('Owned by ' *CAT &EXCLUDE *BCAT &OWNCNTA +
63.00          *CAT ' Not owned by ' *CAT &EXCLUDE *BCAT +
64.00          &OTHERA *CAT ' Bypassed objects ' *CAT +
65.00          &BYPCNTA) MSGTYPE(*COMP)
66.00          ENDPGM

```

Appendix E. Converting RPG from System/38 to the AS/400 System

This appendix provides information about converting RPG from System/38 to the AS/400 System.

RPG/400 features that will not run on System/38 include:

- System/38 does not support the AS/400 naming convention for file names. The AS/400 object naming convention is library-name/object-name. The RPG/400 compiler will accept the System/38 naming convention (OBJECT.LIBRARY) only when the compiler is called under the System/38 environment. Any run time messages issued by the System/38 environment will display the library, file, member, and program names in the AS/400 naming convention (LIBRARY/OBJECT). The /COPY statement and the CALL and FREE operation codes require AS/400 naming convention when used in the AS/400 system, the System/38 naming convention when used in the System/38 environment.
- RPG/400 supports ICF files in the AS/400 system AS/400 system.
- The RPG/400 POST feedback area has increased to cover bytes 241 to 528 in the AS/400 system.
- AS/400 system supports numeric variables up to and including 30 digits. The maximum number of decimal digits allowed remains 9.
- AS/400 system supports numerics for the operation code MOVEA.
- AS/400 system has three built-in subroutines: SUBR23R3, SUBR40R3, and SUBR41R3 that are not available on System/38.
- AS/400 system has additional *STATUS values in the AS/400 system.
- AS/400 system places a limit of three on the number of parameter values that you may enter on the command line without specifying the parameter keyword in the AS/400 system.

Converting to AS/400 System

The following table presents the differences between the compiler options for System/38 RPG III and AS/400 RPG/400. Each option is a parameter value for the parameter keyword that immediately precedes it.

RPG/400 Parameter	System/38 Parameter	RPG/400 Options	System/38 Options	Comments
REPLACE	N/A			New parameter
		*YES	N/A	New option
		*NO	N/A	New option
AUT	PUBAUT			AUT replaces PUBAUT
		*CHANGE	*NORMAL	*CHANGE replaces *NORMAL
		*EXCLUDE	*NONE	*EXCLUDE replaces *NONE
		*USE	N/A	New option
		authorization- list-name	N/A	New option
PGM	PGM			Existing parameter
		*CURLIB	N/A	New option/new default
SRCFILE	SRCFILE			Existing parameter
		*CURLIB	N/A	New option
PRTFILE	PRTFILE			Existing parameter
		*CURLIB	N/A	New option
OPTION	OPTION			Existing parameter
		*SECLVL	N/A	New option
		*NOSECLVL	N/A	New option

Glossary

access path. (1) The order in which records in a database file are organized for processing by a program. See *arrival sequence access path* and *keyed sequence access path*. (2) (SQL) The path used to locate data specified in SQL statements. An access path can be indexed, sequential, or a combination of both.

advanced peer-to-peer networking (APPN). Data communications support that routes data in a network between two or more APPC systems that do not need to be adjacent.

advanced printer function. A function of the AS/400 Application Development Tools licensed program that allows a user to design symbols, logos, special characters, large characters, and forms tailored to a business or data processing application, and supports printing of any design on the 5224 or 5225 dot matrix printer.

advanced program-to-program communications (APPC). Data communications support that allows programs on an AS/400 system to communicate with programs on other systems having compatible communications support. APPC is the AS/400 method of using the SNA LU session type 6.2 protocol.

alert. A record sent to a focal point to identify a problem or an impending problem.

alert controller description. A controller description that defines the system to which alerts will be sent on an alert controller session.

alert controller session. A type of SSCP-PU session on which alerts can be sent to a system that is designated as an alert focal point.

all authority. An object authority that allows the user to perform all operations on the object except those limited to the owner or controlled by authorization list management authority. The user can control the object's existence, specify the security for the object, and change the object. Contrast with *exclude authority*.

all object authority. A special authority that allows users to use all system resources without having specific authority to the resources. See also *save system authority*, *job control authority*, *security administrator authority*, *service authority*, and *spool control authority*.

American National Standard Code for Information Interchange (ASCII). The code developed by American National Standards Institute for information exchange among data processing systems, data com-

munications systems, and associated equipment. The ASCII character set consists of 7-bit control characters and symbolic characters, plus one parity-check bit.

API. See *application program interface (API)*.

APPC. See *advanced program-to-program communications (APPC)*.

application program. A program used to perform a particular data processing task such as inventory control or payroll.

application program interface (API). A functional interface supplied by the operating system or a separately orderable licensed program that allows an application program written in a high-level language to use specific data or functions of the operating system or the licensed program.

APPN. See *advanced peer-to-peer networking (APPN)*.

area-specific help. In an application program, help information supplied by the programmer for the area of the screen where the cursor is located when the person using the program presses the Help key.

arrival sequence access path. An access path to a database file that is arranged according to the order in which records are stored in the physical file. See also *keyed sequence access path* and *access path*.

ASCII. See *American National Standard Code for Information Interchange (ASCII)*.

ASP. See *auxiliary storage pool (ASP)*.

attribute. (1) A characteristic or property of one or more objects. (2) (SQL) In database design, a characteristic of an entity; for example, the telephone number of an employee is one of that employee's attributes. (3) (BGU) The characteristics that make up the chart format.

attribute character. A character associated with a field in a display file record format that defines how the field is displayed.

automatically started job entry. A work entry in a subsystem description that specifies a job to be automatically started each time the subsystem is started.

auxiliary storage. All addressable disk storage other than main storage.

auxiliary storage pool (ASP). A grouping of disk units. See also *system ASP* and *user ASP*.

basic data exchange. A file format for exchanging data on diskettes or tape between systems or devices.

binary synchronous communications (BSC). A data communications line protocol that uses a standard set of transmission control characters and control character sequences to send binary-coded data over a communications line. See also *synchronous data link control (SDLC)*.

BSC. See *binary synchronous communications (BSC)*.

character generator utility (CGU). A function of the AS/400 Application Development Tools licensed program that is used to define and maintain user-defined double-byte characters and related sort information.

checksum protection. A function that protects data stored in the system auxiliary storage pool from being lost because of the failure of a single disk. When checksum protection is in effect and a disk failure occurs, the system automatically reconstructs the data when the system program is loaded after the device is repaired.

checksum set. Units of auxiliary storage defined in groups to provide a way for the system to recover data if a disk failure occurs when checksum protection is in effect.

CL. See *control language (CL)*.

class attributes. The values in the Change Job (CHGJOB) command that control the processing of routing steps in a job. These values include the run priority, time slice, delete, and default wait time-out parameters.

command definition. An object that contains the definition of a command (including the command name, parameter descriptions, and validity checking information) and identifies the program that performs the function requested by the command. The system-recognized identifier for the object type is *CMD.

command file. A remote job input stream that can contain host system commands and job control language (JCL), data, and RJE control statements (READFILE or EOF). Contrast with *data file*.

commit. (1) To make all changes permanent that were made to one or more database files since the last commit or rollback operation, and make the changed records available to other users. (2) (SQL) The process that allows data changed by one application or user to be used by other applications or users. When a commit operation occurs, the locks are released to allow other applications to use the changed data.

commitment control. A means of grouping file operations that allows the processing of a group of database changes as a single unit through the Commit command or the removal of a group of database changes as a single unit through the Rollback command.

control language (CL). The set of all commands with which a user requests system functions.

control language (CL) program. A program that is created from source statements consisting entirely of control language commands.

controller configuration. The process of creating configuration descriptions for the local (device configuration) and remote (communications configuration) controllers that make up a data processing system.

cross-reference listing. The part of the compiler listing that tells where files, fields, and indicators are defined, referred to, and changed in a program.

cryptography. The transformation of data to conceal its meaning; secret code.

current library. The library that is specified to be the first user library searched for objects requested by a user. The name for the current library can be specified on the Sign-On display or in a user profile. When you specify an object name (such as the name of a file or program) on a command, but do not specify a library name, the system searches the libraries in the system part of the library list, then searches the current library before searching the user part of the library list. The current library is also the library that the system uses when you create a new object, if you do not specify a library name.

data area. A storage area used to communicate data such as CL variable values between the programs within a job and between jobs. The system-recognized identifier for the data area is *DTAARA.

data description specifications (DDS). A description of the user's database or device files that is entered into the system in a fixed form. The description is then used to create files.

data file. (1) A collection of related data records organized in a specific order. (2) A file created by the specification of FILETYPE(*DATA) on the create commands. Contrast with *source file*. (3) (BASIC) The table containing the values from the DATA statements of a program. (4) (RJE) A remote job input stream that can contain host system commands and job control language as well as data. Contrast with *command file*.

data queue. An object that is used to communicate and store data used by several programs in a job or

between jobs. The system-recognized identifier is *DTAQ.

DDM. See *distributed data management (DDM)*.

DDS. See *data description specifications (DDS)*.

dedicated service tools (DST). The part of the service function used to service the system when the operating system is not working.

device configuration. The physical placement of display stations, printers, and so forth; and the configuration descriptions that describe the physical configuration to the system and describe how the configuration will be used by the system. See also *line configuration* and *controller configuration*.

device file. A file that contains a description of how data is to be presented to a program from a device or how data is to be presented to the device from the program. Devices can be display stations, printers, a diskette unit, tape units, or a remote system.

display station pass-through. A communications function that allows a user to sign on to one system (either an AS/400 system, System/38, or System/36) from another system (either an AS/400 system, System/38, or System/36) and use that system's programs and data. Sometimes called pass-through.

distributed data management (DDM). A function of the operating system that allows an application program or user on one system to use database files stored on remote systems. The systems must be connected by a communications network, and the remote systems must also be using DDM.

document library. The system library named QDOC that contains all documents and folders.

DST. See *dedicated service tools (DST)*.

end node. A node in an APPN network that can be a source or target node, but does not provide any routing or session services to any other node.

exclude authority. An object authority that prevents the user from using the object or its contents. Contrast with *all authority*.

folder. A directory for documents. A folder is used to group related documents and to find documents by name. The system-recognized identifier for the object type is *FLR. Compare with *library*.

formatted diskette. A diskette on which the control information is written but which may or may not contain any data.

GDDM. See *graphical data display manager (GDDM)*.

general-purpose library. The library shipped with the system that contains IBM-provided objects required

for many system functions and user-created objects that are not explicitly placed in a different library when they are created. Named QGPL.

graphic character set. A set of graphic characters in a code page.

graphical data display manager (GDDM). A function of the operating system that processes both text and graphics for output on a display, printer, or plotter.

graphics symbol set. An object that can contain either lines or images. The system-recognized identifier for the object type is *GSS.

group job. One of up to sixteen interactive jobs that are associated in a group with the same work station device and user.

independent work station. A work station that is programmable and operates independently of a host system, but can communicate with a host system and use selected system services. A Personal System/2 is an example of an independent work station.

initial program load (IPL). The process that loads the system programs from the system auxiliary storage, checks the system hardware, and prepares the system for user operations.

IPL. See *initial program load (IPL)*.

job accounting. A system function that collects information about a job's use of system resources and records that information in a journal.

job control authority. A special authority that allows a user to: change, delete, display, hold, and release all files on output queues; hold, release, and clear job queues and output queues; start writers to output queues; hold, release, change, and end other users' jobs; change the class attributes of a job; end subsystems; and start (IPL) the system. See also *all object authority*, *save system authority*, *security administrator authority*, *service authority*, and *spool control authority*.

job description. A system object that defines how a job is to be processed. The object name is *JOBQ.

job name. The name of the job as identified to the system. For an interactive job, the job is assigned the name of the work station at which the job was started; for a batch job, the name is specified in the command used to submit the job. Contrast with *qualified job name*.

job queue. A list of batch jobs waiting to be started or processed by the system. The system-recognized identifier for the object type is *JOBQ.

journal. A system object used to record entries in a journal receiver when a change is made to the data-

base files associated with the journal. The object type is *JRN. See also *journal receiver*.

journal receiver. A system object that contains journal entries recorded when changes are made to the data in database files or the access paths associated with the database files. The object type is *JRNRV. See also *journal*.

K. 1024 bytes of storage.

keyed sequence access path. An access path to a database file that is arranged according to the contents of key fields contained in the individual records. See also *arrival sequence access path* and *access path*.

library. (1) An object on disk that serves as a directory to other objects. A library groups related objects, and allows the user to find objects by name. Compare with *folder*. (2) The set of publications for a system.

licensed program. An IBM-written program that performs functions related to processing user data.

line configuration. The process of creating configuration descriptions for the lines that make up a data processing system. See also *controller configuration* and *device configuration*.

local work station. A work station that is connected directly to the system without a need for data transmission functions. Contrast with *remote work station*.

logical unit (LU). One of three types of network addressable units that serve as a port through which a user accesses the communications network. See also *physical unit*, and *system services control point (SSCP)*.

LU. See *logical unit (LU)*.

mode. The session limits and common characteristics of the sessions associated with advanced-program-to-program communications (APPC) devices managed as a unit with a remote location.

mode description. A system object created for advanced-program-to-program communications (APPC) devices that describe the session limits and the characteristics of the session, such as the maximum number of sessions allowed, maximum number of conversations allowed, the pacing value for incoming and outgoing request/response units, and other controlling information for the session.

network. A collection of data processing products connected by communications lines for exchanging information between stations.

network node. A node that can define the paths or routes, control route selection, and handle directory services for APPN.

node. (1) One of the systems or devices in a network. (2) A location in a communications network that provides host processing services. (3) (X.25) A point where packets are received, stored, and forwarded to another location (or data terminal equipment) according to a routing method defined for the network. (4) (APPN) See *network node* and *end node*.

normal queue. A list of distribution items for a next system (queue for each next system) with a low priority for sending. There is one normal queue for each next system. When send times and queue depths are satisfied for both the priority and normal queues at the same time, the priority queue is sent first. Contrast with *priority queue*.

object. (1) A named storage space that consists of a set of characteristics that describe itself and, in some cases, data. An object is anything that exists in and occupies space in storage and on which operations can be performed. Some examples of objects are programs, files, libraries, and folders. (2) (SQL) Anything that can be created or manipulated with SQL statements, such as databases, tables, views, or indexes.

object authority. A specific authority that controls what a system user can do with an entire object. For example, object authority includes deleting, moving, or renaming an object. There are three types of object authorities: object operational, object management, and object existence.

object distribution. A function that allows a user to send source and data files, save files, job streams, spooled files, and messages to another user, either locally or on a SNADS network.

object existence authority. An object authority that allows the user to delete the object, free storage of the object, save and restore the object, transfer ownership of the object, and create an object that was named by an authority holder.

object management authority. An object authority that allows the user to specify the authority for the object, move or rename the object, and add members to database files.

object name. The name of an object. Contrast with *qualified name*.

output queue. An object that contains a list of spooled files to be written to an output device, such as a printer.

override. A value that replaces a previous value.

pass-through. See *display station pass-through*.

physical unit. One of three types of network addressable units. A physical unit exists in each node of an

SNA network to manage and monitor the resources (such as attached links and adjacent link stations) of a node, as requested by an system services control point logical unit (SSCP-LU) session.

presentation graphics routines (PGR). A group of routines within the operating system that allows business charts to be defined and displayed procedurally through function routines. Contrast with *graphical data display manager (GDDM)*.

priority queue. A queue that contains distribution queue entries for distributions with a service level of fast, status, or data high. When send times and queue depths are satisfied for both the priority and normal queues, the priority queue is serviced first. Contrast with *normal queue*.

problem analysis. The process of finding the cause of a problem. For example, a program error, device error, or user error.

problem log. A record of problems and of the status of the analysis of those problems.

program message queue. An object used to hold messages that are sent between program calls of a routing step. The program message queue is part of the job message queue.

program temporary fix (PTF). A temporary solution to, or bypass of, a defect in a current release of a licensed program.

PTF. See *program temporary fix (PTF)*.

QGPL. See *general-purpose library*.

qualified job name. A job name and its associated user name and a system-assigned job number. Contrast with *job name*.

qualified name. The name of the library containing the object and the name of the object. Contrast with *object name*.

remote job entry (RJE). A function of the AS/400 Communications Utilities licensed program that allows a user to submit a job from a display station on the AS/400 system to a System/370-type host system.

remote work station. A work station that is connected to the system by data communications. Contrast with *local work station*.

return code. In data communications, a value sent by the system to a program to indicate the results of an operation by that program.

RJE. See *remote job entry (RJE)*.

RPG. Report Program Generator. A programming language designed for writing application programs for business data processing requirements. The

application programs range from report writing and inquiry programs to applications such as payroll, order entry, and production planning.

save system authority. A special authority that allows the user to save and restore all objects on the system and free storage of all objects on the system. See also *all object authority, job control authority, security administrator authority, service authority, and spool control authority*.

SDLC. See *synchronous data link control (SDLC)*.

security administrator authority. A special authority that allows a user to add users to the system distribution directory, to create and change user profiles, to add and remove access codes, and to perform office tasks, such as delete documents, folders, and document lists, and change distribution lists for other users. See also *all object authority, save system authority, job control authority, service authority, and spool control authority*.

service authority. A special authority that allows the user to perform the alter function in the service functions. See also *all object authority, save system authority, job control authority, security administrator authority, and spool control authority*.

SEU. See *source entry utility (SEU)*.

SNA. See *Systems Network Architecture (SNA)*.

SNA distribution services (SNADS). An IBM asynchronous distribution service that defines a set of rules to receive, route, and send electronic mail in a network of systems.

SNADS. See *SNA distribution services (SNADS)*.

source entry utility (SEU). A function of the AS/400 Application Development Tools licensed program that is used to create and change source members.

source file. (1) A file of programming code that is not compiled into machine language. Contrast with *data file*. (2) A file created by the specification of FILETYPE(*SRC) on the Create command. A source file can contain source statements for such items as high-level language programs and data description specifications.

source system. The system that issues a request to establish communications with another system. (DDM) The system on which an application program issues a request to use a remote file. Contrast with *target system*.

spool. The system function of putting jobs into a storage area to wait to be printed or processed.

spool control authority. A special authority that allows the user to perform spooling functions, such as

display, delete, hold, and release spooled files on the output queue for himself and other users. This authority also allows the user to change the spooled file attributes, such as the printer used to print the file. See also *all object authority*, *save system authority*, *job control authority*, *security administrator authority*, and *service authority*.

Structured Query Language/400 (SQL/400). An IBM licensed program that is the SAA* version of SQL.

SSCP. See *system services control point (SSCP)*.

synchronous data link control (SDLC). (1) A form of communications line control that uses commands to control the transfer of data over a communications line. (2) A communications discipline conforming to subsets of the Advanced Data Communication Control Procedures (ADCCP) of the American National Standards Institute (ANSI) and High-Level Data Link Control (HDLC) of the International Standards Organization (ISO), for transferring synchronous, code-transparent, serial-by-bit information over a communications line. Transmission exchanges may be duplex or half-duplex over switched or nonswitched lines. The configuration of the connection may be point-to-point, multipoint, or loop. Compare with *binary synchronous communications (BSC)*.

system ASP. The auxiliary storage pool where system programs and data reside. It is the storage pool used if a storage pool is not defined by the user. See also *auxiliary storage pool* and *user ASP*.

system configuration list. A list of devices that are provided with the system.

system distribution directory. A list of user IDs and identifying information, such as network addresses, used to send distributions.

system services control point (SSCP). A focal point within an SNA network for managing the other systems and devices, coordinating network operator requests and problem analysis requests, and providing directory routing and other session services for network users.

system time. The elapsed time from the point where the system was started to the current time. If the system time is changed to the local time when the system is started, the current system time is the local time of day.

System/36 environment. A function of the operating system that processes most of the System/36 operator control language (OCL) statements and procedure statements to run System/36 application programs and allows the user to process the control language (CL) commands. Contrast with *System/38 environment*.

System/38 environment. A function of the operating system that processes most of the System/38 control language (CL) statements and programs to run System/38 application programs. Contrast with *System/36 environment*.

Systems Network Architecture (SNA). The description of the logical structure, formats, protocols, and operational sequences that are used for transmitting information units through networks, as well as controlling the configuration and operation of networks.

Systems Network Architecture distribution services. See *SNA distribution services (SNADS)*.

target system. In a distributed data management (DDM) network, the system that receives a request from an application program on another system to use one or more files located on the target system. Contrast with *source system*.

temporary library. A library that is automatically created for each job to contain temporary objects that are created by the system for that job. The objects in the temporary library are deleted when the job ends. Named QTEMP.

uninterruptible power supply. A source of power from a battery installed between the commercial power and the system that keeps the system running, if a commercial power failure occurs, until it can complete an orderly end to system processing.

user ASP. One or more auxiliary storage pools used to isolate journals, journal receivers, and save files from the other system objects stored in the system ASP. See also *auxiliary storage pool* and *system ASP*.

user profile. An object with a unique name that contains the user's password, the list of special authorities assigned to a user, and the objects the user owns.

vector symbol set (VSS). A set of characters each of which is treated as a small picture and is described by a sequence of lines and arcs. Characters in a vector symbol set can be drawn to scale, rotated, and positioned precisely. Contrast with *image symbol set (ISS)*; see also *graphics symbol set*.

work station. A device used to transmit information to or receive information from a computer; for example, a display station or printer.

work station user profile. The system-supplied user profile that has the authority required by work station operators. Named QUSER.

X.25. In data communications, a specification of the CCITT that defines the interface to an X.25 (packet-switching) network.

Bibliography

This manual is also referred to as *System/38 Environment Programmer's Guide/Reference*.

The manuals below are listed with their full title, base order number, and short title. When these manuals are referred to in this manual, the short title is used.

- *Communications and Systems Management Guide (Alerts and Distributed Systems Node Executive)*, SC41-9661. **Short Title:** *Alerts and DSNX Guide*. Provides information for configuring AS/400 systems to use the remote management support (distributed host command facility), the change management support (distributed systems node executive), and the problem management support (alerts).
- *Distributed Data Management Guide*, SC41-9600. **Short Title:** *DDM Guide*. Provides the application programmer or system programmer with information about remote file processing.
- *Communications: Distribution Services Network Guide*, SC41-9588. **Short Title:** *Distribution Services Network Guide*. Provides the system operator or system administrator with information about administering data communications applications on an AS/400 system.
- *Communications: Intersystem Communications Function Programmer's Guide*, SC41-9590. **Short Title:** *ICF Programmer's Guide*. Provides information to write application programs that use AS/400 communications and the OS/400-ICF file.
- *Service: AS/400* 9402 Problem Isolation Guide*, SY44-0001. **Short Title:** *AS/400* 9402 Problem Isolation Guide*. Supplies communications configurations reference material, such as the discussion of specific commands and parameters.
- *Communications: Operating System/400* Communications Configuration Reference*, SC41-0001. **Short Title:** *OS/400* Communications Configuration Reference*. Supplies communication configuration examples.
- *Communications: Management Guide*, SC41-0024. **Short Title:** *Communications Management Guide*. Supplies management information relating to communications, specific work management, communications error handling, and performance.
- *Device Configuration Guide*, SC41-8106. **Short Title:** *Device Configuration Guide*. Provides the system operator or system administrator with information on how to do an initial configuration and how to change that configuration. It also contains conceptual information about device configuration.
- *Languages: Systems Application Architecture* AD/Cycle* RPG/400* Reference*, SC09-1349. **Short Title:** *RPG/400* Reference*. Provides the application programmer with the information needed to write programs for the AS/400 system using the RPG/400 programming language.
- *Migrating from System/38 Planning Guide*, GC41-9624. **Short Title:** *Migrating from System/38 Planning Guide*. Provides the application programmer, system administrator, or data processing manager with information to help them migrate their products and applications with the System/38 Migration Aid.
- *Systems Application Architecture* OfficeVision/400*: Using OfficeVision/400*, SC41-9616. **Short Title:** *Using OfficeVision/400**. Provides the office user with detailed information on how to use OfficeVision/400. It contains procedural as well as reference information and can be used with the Office online information.
- *Systems Application Architecture* OfficeVision/400*: Learning about OfficeVision/400 Word Processing*, SC41-9617. **Short Title:** *Learning about OfficeVision/400* Word Processing*. Provides office users with information to help them learn how to use the word processing functions of OfficeVision/400.
- *Systems Application Architecture* OfficeVision/400*: Using OfficeVision/400 Word Processing*, SC41-9618. **Short Title:** *Using OfficeVision/400* Word Processing*. Provides the office user with detailed information on how to use the word processing functions of OfficeVision/400.
- *Backup and Recovery Guide*, SC41-8079. **Short Title:** *Backup and Recovery Guide*. Provides the system programmer with information about the different media available to save and protect system data, as well as a description of how to record changes made to database files and how that information can be used for system recovery and activity report information.
- *Programming: Reference Summary*, SX41-0028. **Short Title:** *Programming Reference Summary*. Provides the system operator, system programmer, or system administrator with quick reference information about the structure of the AS/400 commands.
- *Programming: Control Language Programmer's Guide*, SC41-8077. **Short Title:** *CL Programmer's Guide*. Provides the application programmer or system programmer with a wide-ranging discussion of AS/400 programming topics.
- *Programming: Control Language Reference*, SC41-0030. **Short Title:** *CL Reference*. Provides the application programmer or system programmer with a description of the AS/400 control language (CL) and its commands.

- *Cryptographic Support/400 User's Guide*, SC41-8080. **Short Title:** *Cryptographic Support/400 User's Guide*. Provides the system operator or system programmer with a description of the data security capabilities of the AS/400 Cryptographic Support.
- *Database Guide*, SC41-9659. **Short Title:** *Database Guide*. Provides the application programmer or system programmer with a detailed discussion of the AS/400 database structure, including information on how to create, describe, and manipulate database files on the system.
- *Data Description Specifications Reference*, SC41-9620. **Short Title:** *DDS Reference*. Gives descriptions of the entries and keywords needed to describe database files (both logical and physical) and certain device files (for displays and printers) external to the user's programs on the AS/400 DDS Coding Form.
- *Data Management Guide*, SC41-9658. **Short Title:** *Data Management Guide*. Provides the application programmer or system programmer with information about managing key aspects of the system.
- *Programming: Performance Tools/400 Guide*, SC41-8084. **Short Title:** *Performance Tools/400 Guide*. Provides the system programmer with an overview of AS/400 performance tools and explains how the tools can be used to help manage system performance.
- *Programming: Work Management Guide*, SC41-8078. **Short Title:** *Work Management Guide*. Provides the system programmer with information about how to create an initial work management environment and how to change it.
- *System/38 Uninterruptible Power Supply Planning Guide*, GA21-9421, provides information about the basic uninterruptible power supply (UPS).
- *System/38 Compatibility: Data File Utility/38 User's Guide and Reference*, SC09-1217. **Short Title:** *DFU/38 User's Guide and Reference*. Provides the work station operator, application programmer, system programmer, and data processing manager with information about using the DFU/38 on the AS/400 system.
- *System/38 Compatibility: Query/38 User's Guide and Reference*, SC09-1218. **Short Title:** *Query/38 User's Guide and Reference*. Provides the work station operator, application programmer, system programmer, and data processing manager with information about using Query/38 on the AS/400 system.
- *System/38 Compatibility: Text Management/38 User's Guide and Reference*, SC41-9759. **Short Title:** *Text Management/38 User's Guide and Reference*. Provides the work station operator, application programmer, system programmer, and data processing manager with information about using Text Management/38 on the AS/400 system.
- *Question-and-Answer Database Coordinator's Guide*, SC41-8086. **Short Title:** *Q & A Database Coordinator's Guide*. Describes how to use the question-and-answer (Q & A) function to search through questions and answers stored in a Q & A database on your system.
- *System/38 to AS/400 Migration Aid User's Guide and Reference*, SC09-1165. **Short Title:** *System/38 to AS/400 Migration Aid User's Guide and Reference*. Provides the system operator, application programmer, system programmer, and data processing manager with information about using the System/38 Migration Aid to move System/38 objects to the AS/400 system using menus and displays, or commands.
- *System Operator's Guide*, SC41-8082. **Short Title:** *Operator's Guide*. Provides the system operator or system administrator with information about how to use the system unit operator panel, send and receive messages, respond to error messages, start and stop the system, use the display station function keys, control devices, and also process and manage jobs on the system.

Index

A

access path

- definition G-1
- from System/38 2-1
- rebuild 4-1
- restoration 1-3
- selection specifications 4-4
- sharing 4-4

address regeneration 2-1

advanced peer-to-peer networking (APPN) 2-31, G-1

advanced printer function (APF)

- definition G-1

advanced program-to-program communications (APPC)

- AS/400 system 4-5
- coexistence 5-2
- comparing to advanced peer-to-peer networking (APPN) 2-29
- definition G-1
- device configuration 4-2
- device configuration objects 2-2
- establishing 2-29
- local names 2-30

alerts

- controller description
 - definition G-1
- controller session
 - definition G-1
- definition G-1
- format 2-1
- network attributes 7-8
- new commands 4-2

all authority G-1

all object authority G-1

ALTSEQ keyword B-1

American National Standard Code for Information Interchange (ASCII) G-1

APF (advanced printer function)

- definition G-1

API (application program interface) G-1

APPC (advanced program-to-program communications)

- AS/400 system 4-5
- coexistence 5-2
- comparing to advanced peer-to-peer networking (APPN) 2-29
- definition G-1
- device configuration 4-2
- device configuration objects 2-2
- establishing 2-29
- local names 2-30

Application Development Tools 1-13, 2-62

application program G-1

application program interface (API) G-1

APPN (advanced peer-to-peer networking) 2-31, G-1

area-specific help G-1

arrival sequence access path G-1

ASCII (American National Standard Code for Information Interchange) G-1

ASP (auxiliary storage pool)

- dedicated service tools (DST) 2-2
- definition G-1
- migration 7-4
- specifications 4-2

attribute G-1

attribute character G-1

authority

- group 2-40
- private 2-40
- program adopt 2-40
- public 2-40, 2-43
- restore function (RSTAUT) 2-44
- *EXCLUDE keyword 2-41
- *SPLCTL keyword 2-52

authorization list 2-44

automatic start job

- attended IPL 2-13
- configuration menu 2-14
- controlling subsystem 2-13
- initial program load (IPL) 2-54
- job description 2-53
- system configuration 7-4

automatically started job entry G-1

auxiliary storage G-1

auxiliary storage pool (ASP)

- dedicated service tools (DST) 2-2
- definition G-1
- migration 7-4
- specifications 4-2

B

BASIC 2-65, 4-17

basic data exchange G-2

BGU (business graphics utility) 2-61

Bibliography H-1

binary synchronous communications (BSC)

- definition G-2
- return codes used 2-35
- support on Operating System/400 program 2-2, 4-2

BSC (binary synchronous communications)

- definition G-2
- return codes used 2-35
- support on Operating System/400 program 2-2, 4-2

BSCF38 file type 4-5

business graphics utility (BGU) 2-61

C

card 2-2, 4-2

cascading vary

definition 2-10

CGU (character generator utility) 2-62, G-2

changes

hardware 1-3

operational 1-4

programming 1-4

character generator utility (CGU) 2-62, G-2

check library owner command (CHKLIBOWN) D-7

checksum protection G-2

checksum set G-2

checksums

dedicated service tools (DST) 4-2

migration 2-2, 7-4

CL (control language) G-2

CL (control language) program

changes 4-2

conversion 3-1

definition G-2

migration 2-3

new format 2-35

OS/400 program 6-4

qualified names 4-2

syntax 2-3, 6-4

class attributes G-2

class object

changes 2-2, 4-3

QGPL 7-6

class of service 2-32

CLNPRT command 1-4

CMNF38 file type 4-5

COBOL

ANSI 74 3-5, 4-17

ANSI 85 3-5, 4-17

conversion 6-5

differences 4-17

licensed program 2-66

coexistence

advanced program-to-program communications
(APPC) 5-2

alerts 5-5

communication 5-2

distributed data management (DDM) 5-2

exchange ID 5-1

journal objects 5-6

media 5-1

mixed files 5-2

pass-through 5-2

PC data 5-5

save file data 5-1

source, testing 1-10

systems network architecture distribution services
(SNADS) 5-2

command

analyzer 1-7

default 1-1, 1-4

definition 4-3

display 1-4

library qualified 1-9

library qualifier 1-9

library search 1-7

name conversion 1-1, 3-1

parameter 2-2

prompter 1-13

public 7-7

syntax 1-6

System/38

ENDJOB C-1

ENDSBS C-1

command definition G-2

command file G-2

commit G-2

commitment control

definition G-2

communications

device configuration 2-4

files 3-4

references 4-3

configuration

menu 2-14

SNA distribution services (SNADS) 7-8

configuration list

local location 2-31

remote location 2-31

console 2-4

control language (CL) G-2

control language (CL) program G-2

controller configuration G-2

conversion

details 4-1

environments 3-1

keyword name 3-1

valid comments 3-1

copy file 2-4

CPYF command 2-4

CPYSPLF command 1-4

cross-reference

DSPFD command 2-5

cross-reference listing G-2

CRP (Cryptographic Facility) 2-61

CRT commands 1-14, 4-12

CRTCLPGM command 1-9

CRTDEVD command 6-3

Cryptographic Facility (CRP) 2-61

cryptography G-2

CSNAP commands 1-4

current library

create commands default

changed from QGPL 4-9

new support 1-14

replace QGPL 3-3

current library (*continued*)
definition G-2
product
duration of command 4-9

CVTCLSRC command
defaults 3-2
limits 6-3
use 3-1

D

data area 2-5, G-2

data description specifications (DDS)
definition G-2
display files 2-6
files 6-4
keyword changes B-1
keywords 2-6, 4-5
qualified names 4-4
source types 2-6
spooled file 2-7
syntax 4-3

data file utility (DFU)
converting 3-5
functions 4-16
in System/38 environment 1-1, 3-3
interactive data utility (IDU) 2-62
parameters 2-27
source 6-3

data interchange 1-10, 6-1

data management changes 3-3

data queue
definition G-2

database
function 2-5, 6-4
syntax 2-5, 6-4

DDM (distributed data management)
coexistence 5-2
communications 4-6
definition G-3
distributed data management (DDM) 2-11
file name 5-3
licensed program 2-61
migration 5-3
qualified name 5-4
RMTLOCNAME parameter defaults 4-6

DDS (data description specifications)
definition G-2
display files 2-6
files 6-4
keyword changes B-1
keywords 2-6, 4-5
qualified names 4-4
source types 2-6
spooled file 2-7
syntax 4-3

debug authority 2-7, 4-6

dedicated service tools (DST)
auxiliary storage pool (ASP) 2-2

dedicated service tools (DST) (*continued*)
checksums 4-2
definition G-3
initial program load (IPL) 2-7
OS/400 operating system 4-6
service function 2-44

DEV parameter value 2-51

device configuration
ADDWSE command 2-9
automatic configuration 2-8
commands 1-4
CRTCLUD command 2-8
CRTDEVD command 2-7
CRTLIND command 2-8
default 2-9
definition G-3
different commands 2-7
objects 1-2
OS/400 program 4-6
QAUTOCFG parameter 2-8
system configuration 7-4
work station allocation 2-9

device description 2-31

device files
definition G-3

DFU (data file utility)
converting 3-5
functions 4-16
in System/38 environment 1-1, 3-3
interactive data utility (IDU) 2-62
parameters 2-27
source 6-3

dictionary 2-62
differences
hardware 1-3
operational 1-4
programming 1-4

disk devices 1-3

diskette
default 2-10
migration aid 1-2
spooling 2-52

display commands
DSPLIB command 2-10
new commands 2-11
prevent user changes 2-10

display files 2-11, 3-4

display formatting
function keys 2-11
help 2-11
option numbers 2-11
qualified name 2-11

display station pass-through G-3
distributed data management (DDM)
coexistence 5-2
communications 4-6
definition G-3
distributed data management (DDM) 2-11

distributed data management (DDM) (continued)

- file name 5-3
- licensed program 2-61
- migration 5-3
- qualified name 5-4
- RMTLOCNAME parameter defaults 4-6

document library G-3

document password 2-38

DSPF keyword 2-35

DSPFD command

- mapping function 2-6
- outfile support 2-5
- source 2-5

DSPOBJAUT command 2-41, 2-42

DSPSIZ keyword B-1

DST (dedicated service tools)

- auxiliary storage pool (ASP) 2-2
- checksums 4-2
- definition G-3
- initial program load (IPL) 2-7
- OS/400 operating system 4-6
- service function 2-44

E

edit descriptions 2-11

emulation (3270)

- attention key 2-11
- KBDTYP entries 2-11
- pass-through 4-7
- 3274 control unit 2-11

end node G-3

ENTCBLDBG command A-28

ERRMSGID keyword B-1

error handling 2-11

EVOKE keyword B-1

exchange ID

- coexistence 5-1
- prefix 2-12

exclude authority G-3

F

FIFO (first in, first out) 4-4

file changes 3-3

finance 2-12

folder G-3

FORMAT keyword B-1

formatted diskette G-3

FROMFILE parameter

- as default for TORCDLEN parameter A-9
- distributed data management (DDM) file specified as 2-4, A-8

function keys 2-11

G

GDDM (graphical data display manager)

- definition G-3

general-purpose library

- definition G-3

graphic character set

- definition G-3

graphical data display manager (GDDM)

- definition G-3

graphics symbol set

- definition G-3

group job

- definition G-3

group profile authority 2-40

H

hardware differences 1-3

help

- data description specifications (DDS)
 - functions 2-12, 4-5
 - display formats 4-6
 - IBM displays 2-11
 - QHLPSYS library 2-12
 - text 4-7

I

IBM-supplied programs

- AS/400 system 4-7
- not supported 2-13
- objects changes 7-5
- supported 2-13

ICF (intersystem communications function)

- format name 4-5
- new commands 4-7

ICFF keyword

- definition 2-6
- file 4-5

IDU (interactive data utility)

- data file utility (DFU) 2-62
- independent work station support 2-63
 - Query 2-63
- screen design aid (SDA) 2-63
- source entry utility (SEU) 2-63

independent work station

- See *also* PC Support
- definition G-3

initial program load (IPL)

- address regeneration 2-1
- console device 2-56
- dedicated service tools (DST) 2-44
- default 2-13
- definition G-3
- diskette 2-35
- OS/400 4-8
- system objects 7-5
- system value 2-53

install function

- OS/400 4-8
- restore device configuration 2-15
- tape install 2-14

interactive data utility (IDU)
data file utility (DFU) 2-62
independent work station support 2-63
Query 2-63
screen design aid (SDA) 2-63
source entry utility (SEU) 2-63

interchanging
communication 5-2
DDM 5-2
journal objects 5-6
media 5-1
mixed files 5-2
PC data 5-5
save file data 5-1

intersystem communications function (ICF)
format name 4-5
new commands 4-7

IPL (initial program load)
address regeneration 2-1
console device 2-56
dedicated service tools (DST) 2-44
default 2-13
definition G-3
diskette 2-35
OS/400 4-8
system objects 7-5
system value 2-53

J

JFILE keyword B-1

job

accounting
changes 4-8
creating journal 7-1
journal 2-15
attribute values 2-49
changing queues 2-37
CHGJOBQE command 2-16
defaults 2-15
descriptions 4-8
DSPJOBQ command 2-15
DSPSBSD command 2-15
naming 2-15
processing 4-8
QGPL description objects 7-6
QGPL queue objects 7-7
QSYSJOBQ keyword 2-15
queue 2-15, 4-9
streams 3-1, 6-3
user profiles 2-55

job accounting G-3

job control authority G-3

job description G-3

job name G-3

job queue G-3

JOIN keyword B-1

journal

definition G-3

journal receiver G-4

JREF keyword B-1

K

K (units) G-4

keyed sequence access path G-4

keywords

ALTSEQ B-1
ERRMSGID B-1
EVOKE B-1
FORMAT B-1
JFILE B-1
JOIN B-1
JREF B-1
MSGCON B-1
PFILE B-1
PRINT B-1
RCVCFM B-1
RCVCONFIRM B-1
RCVTRNRND B-1
REF B-1
REFFLD B-1
SFLMSGID B-1
TRNRND B-1
TRNTBL B-1

L

languages

BASIC 4-17
COBOL 4-17
conversion 3-5
new functions 4-17
PASCAL 4-18
PL/I 4-18
RPG 4-18
syntax 6-5

library

command 1-7
CURLIB parameter 2-16
current 4-9
current, new functions 2-43
definition G-4
DSPLIB command 2-18
DSPOBJD command 2-18
library list 2-18
PRDLIB parameter 2-16
product
installation 2-16
new functions 2-43
product library 2-18
QGPL 2-16, 7-2
QSYS 2-16
QSYSLIBL 2-57
QSYS38 1-7
QUSER38 1-7
restoration 1-3
search 1-7, 2-16

library (continued)
 shipped 2-16

licensed programs
 definition G-4
 migration 1-2, 7-2
 syntax 1-6

line configuration G-4

local names 2-30

local work station G-4

logical files 3-4

logical unit (LU) G-4

logical unit-1 (LU-1)
 return codes 2-35
 support 2-18
 using intersystem communications function (ICF) 4-10

logs
 distribution 2-18
 OS/400 4-10
 problem 2-27

LU (logical unit) G-4

LU-1 (logical unit-1)
 return codes 2-35
 support 2-18
 using intersystem communications function (ICF) 4-10

M

menu
 DSPMNU command 2-18
 GO command 2-18
 message 2-21
 OS/400 4-10
 QCALLMENU 2-19
 QOPRMENU 2-19
 QUSER profile 2-19
 security 2-19

message handling
 break mode 2-20
 changes 4-10
 DSPMSG command 2-20
 IDs 2-19
 message help 2-21
 message queue 2-19
 OS/400 4-10
 PCS 2-22
 problem analysis function 2-21
 problem determination (PDP) codes 2-21
 QSYSOPR message queue 2-20
 severity setting 2-20
 SNDPGMMSG command 2-20
 support on the AS/400 system 6-4
 user profile defaults 2-20

message queue 2-39

migration
 aid 1-2
 authorities information 1-3
 device configuration 1-3

migration (continued)
 media compatibility 7-1
 multiple systems 1-15
 release requirements 7-1
 system objects 7-5
 system values 7-4

mixed file 2-22

mode G-4

mode description G-4

move library objects command (MOVLIBOBJ) D-3

MSGCON keyword B-1

multiple systems, migrating 1-15

MXDF38 file type 4-5

N

naming 2-22, 4-10

network G-4

network attributes
 alerts 2-22
 changes 1-5, 2-22
 migration 2-22, 7-1

network node G-4

node G-4

normal queue G-4

O

object
 definition G-4
 migration D-3
 saved and restored 1-12
 shipped 2-45
 syntax 1-1

object attributes
 create command 1-10, 1-11
 DSPLIB command 1-11
 DSPOBJD command 1-11
 source types
 description 2-24
 OS/400 4-11
 restored from System/38 onto the AS/400 system 2-23
 source entry utility (SEU) 2-23

object authority 2-42, G-4

object distribution
 commands 6-1
 definition G-4
 function 6-2

object existence authority G-4

object management authority G-4

object name G-4

object types 2-25

Operating System/400
 access paths 4-1
 advanced program-to-program communications (APPC) 4-2
 alert 4-2
 approach example 1-14

Operating System/400 (continued)

- ASP (auxiliary storage pool) 4-2
- binary synchronous communications (BSC) 4-2
- card 4-2
- chart format 4-2
- checksums 4-2
- CL (control language) programs 4-2
- class object 4-3
- command definition 4-3
- commitment control 4-3
- communications 4-3
- CRT commands 4-1
- CVTCLSRC command 4-2
- data description specifications (DDS) 4-4
- data queue 4-6
- database 4-3
- debug 4-6
- dedicated service tools (DST) 4-6
- device configuration 4-6
- device files 4-6
- diskette 4-6
- distributed data management (DDM) 4-6
- emulation (3270) 4-7
- finance 4-7
- graphical data display manager (GDDM) 4-7
- graphics symbol set 4-7
- group jobs 4-7
- help 4-7
- HELP key 4-5
- IBM-supplied programs 4-7
- ICFF file type 4-5
- initial program load (IPL) 4-8
- install 4-8
- intersystem communications function (ICF) 4-7
- job accounting 4-8
- job descriptions 4-8
- job queue 4-9
- jobs 4-8
- journal 4-9
- library 4-9
- logical unit-1 (LU-1) 4-10
- logs 4-10
- menu 4-10
- message handling 4-10
- naming 4-10
- object attributes and source types 4-11
- overrides 4-11
- pass-through 4-11
- PC Support 4-8, 4-11
- printers 4-11
- problem analysis function 4-12
- product library 4-9
- programmer menu 4-13
- programming temporary fix (PTF) 4-13
- programs 4-12
- remote location name 4-13
- return codes 4-13
- routing keywords 4-5

Operating System/400 (continued)

- save and restore 4-14
- security 4-14
- SNA distribution services (SNADS) 4-14
- source attribute 4-14
- pool 4-14
- syntax of a valid comment 4-2
- syntax of the parameters 4-1
- System Service Tools (SST) 4-15
- System/38 verbs 4-1
- user profile 4-15
- work management 4-15
- work station 4-16
- X.25 parameter 4-16
- operational changes 1-4**
- operational differences 1-1**
- OPNQRYP command syntax 4-4**
- OS/400 new commands**
 - System/38 commands A-2–A-40
- OS/400-ICF**
 - create file 2-31
 - logical unit-1 (LU-1) 4-10
 - source types 2-13
- out files 2-25**
- output queue**
 - definition G-4
- override**
 - command (OVRPRTF) 4-11
 - definition G-4

P

PASCAL 2-66, 4-18

pass-through

- advanced peer-to-peer networking (APPN) 4-11
- coexistence 5-2
- definition G-4
- mode 2-25
- RMTLOCNAME parameter 4-11
- sign-on 6-3
- testing on System/38 6-4
- 3270 4-11
- 5250 4-11

password

- encryption 2-37
- security levels 2-37
- sign-on 1-4

PC support

- AS/400 system 4-11
- compatible products 1-4
- utility 5-5
- work station 4-8

PCS (personal computer support) 2-13

PDM (programming development manager) 1-6

PDM (programming development manager) 1-13

performance information 2-26

performance tools 2-64

personal computer support (PCS) 2-13

- personal services 2-64
- PFILE keyword B-1
- PGR (presentation graphics routines) G-5
- physical files 3-4
- physical unit G-4
- PL/I 2-66, 4-18
- presentation graphics routines (PGR) G-5
- PRINT keyword B-1
- printers
 - file attributes 2-51
 - files 2-26, 3-4
 - image 2-26
 - output queue 2-49
 - QGPL file 7-7
 - specify with user profile 2-48
 - supported 2-26
- priority queue G-5
- private authority 2-40
- problem analysis G-5
- problem analysis function 2-26, 4-12
- problem determination 2-26
- problem log
 - definition G-5
- profiles 2-43, 7-2
- program
 - create option 1-13, 4-12
 - functions 6-4
 - message queue G-5
 - print device configuration D-1
 - QSYS38/CRTCLPGM command, create option 1-14
 - references 2-27
 - REPLACE(*YES) parameter 4-12
 - syntax rules 1-5
 - template 2-35
 - Migration Aid 1-2
 - restoring program objects 1-3
- program temporary fix (PTF)
 - definition G-5
 - licensed internal code 2-36
 - new commands 2-28
- Programmer Menu
 - alternatives 1-14
 - attributes, designate 1-13
 - data file utility (DFU) 2-27
 - default 2-27
 - query 2-27
- programming changes 4-13
- programming development manager (PDM) 1-6, 1-13
- programming differences 1-1
- prompter keywords 2-5
 - DSPFD command 2-5
- PTF (program temporary fix)
 - definition G-5
- PUBAUT keyword 2-39
- public authorities 2-39, 2-40

Q

- QBASE subsystem 4-16
- QCAEXEC program
 - OS/400 program 3-2, 3-5
 - QCMDXC program 3-5
 - syntax 3-2
- QCL program 1-9, 1-10
- QGPL library
 - data files 7-6
 - definition G-5
 - objects 7-6
 - IBM-supplied 7-6
 - job description 7-6
 - job queue 7-7
 - output queue 7-7
 - subsystem description 7-7
 - system 7-5
 - printer device file 7-7
 - QGPL38 differences 7-6
 - user profile 3-3
- QGPL38 library
 - printer device file 7-7
- QPRTEDEV parameter 2-48, 2-49
- QSYS library 1-6, 7-7
- QSYS38 library 1-6, 1-7
- qualified job name G-5
- qualified name
 - command definition 1-7
 - conversion 3-1
 - definition G-5
 - example 2-11
 - OS/400 syntax 4-2
 - program 2-54
 - RMTFILE parameter 5-3
 - syntax 3-5, 4-10
- query
 - AS/400 system 4-17
 - converting 3-5
 - distributed data management (DDM) support 4-17
 - functions 4-16
 - in System/38 environment 1-1, 3-3
 - OS/400 program 2-27
 - source 6-3
- QUSER38 library 1-7
- QUSRTOOL library 4-10

R

- RA/DHCF 2-28
- RCVCFM keyword B-1
- RCVCONFIRM keyword B-1
- RCVTRNRND keyword B-1
- recovery 2-28
- REF keyword B-1
- REFFLD keyword B-1
- related printed information H-1
- remote job entry (RJE)
 - definition G-5

remote work station G-5
 REPLACE(*NO) parameter 4-13
 REPLACE(*YES) parameter 4-12
 report program generator 2-66
 report program generator (RPG)
 definition G-5
 return code
 AS/400 system 4-13
 changes 6-5
 definition G-5
 display C-1
 file types 2-35, 4-13
 print files C-1
 RJE (remote job entry)
 definition G-5
 RMTLOCNAME parameter
 advanced program-to-program communications
 (APPC)
 link 2-29
 names 2-30
 advanced program-to-program communications)
 APPC
 approach 2-29
 configuration list 2-30
 defaults 2-29
 device description objects 2-30
 directory 2-33
 distributed data management (DDM) 4-6
 internal directory 2-31
 non-advanced program-to-program communica-
 tions (APPC) devices 2-34
 OS/400 program 4-13
 parameters 2-30
 pass-through 4-11
 routing keywords
 RTGAID B-1
 RTGCON B-1
 RTGDEV B-1
 RTGDEVCLS B-1
 RTGFIRST B-1
 RTGFLD B-1
 RTGFMT B-1
 RTGPOS B-1
 RPG (report program generator)
 See also report program generator
 definition G-5
 RTGAID keyword B-1
 RTGCON keyword B-1
 RTGDEV keyword B-1
 RTGDEVCLS keyword B-1
 RTGFIRST keyword B-1
 RTGFLD keyword B-1
 RTGFMT keyword B-1
 RTGPOS keyword B-1

S
 sample programs D-1
 save and restore
 changes 4-14
 data interchange 2-36
 Release 5 2-35
 SAVSYS command 2-36
 space utilization 2-36
 tape devices 2-35
 save files 2-35
 save system authority G-5
 SAVOBJ command 6-3
 SAVSYS command 2-36
 SBMJOB command 3-3, 4-15
 SDLC (synchronous data link control)
 definition G-6
 security
 authorization list 2-44
 commands 2-41
 data authorities 2-42
 default passwords 2-43
 keywords 2-37
 levels 2-36
 object authority 2-42
 OS/400 program 4-14
 parameter 2-41
 password 2-36
 profiles 2-43
 profile, user 2-37
 program changes 1-5
 public authorization 2-43
 sign-on attempts 7-4
 sign-on display 2-46
 single level sign-on 2-37
 *EXCLUDE authority 2-42
 security administrator authority G-5
 SECURITY keyword B-1
 service authority G-5
 service functions
 dedicated service tools (DST) 2-44
 Non-supported System/38 2-45
 system service tools (SST) 2-44
 session description 2-45
 SEU (source entry utility)
 definition G-5
 functions 1-13
 product, support in command definition 2-3
 prompting 1-7
 scan 3-4
 source type 2-2, 2-23
 source, recreated 3-2
 System/38 commands in System/38
 environment 6-3
 type 1-13
 SFLMSGID keyword B-1
 sign-off 2-46
 sign-on
 display 2-47

- sign-on** (*continued*)
 - optional values 2-45
 - password protection 1-4
 - routing entry 2-47
 - routing program 2-45
 - two level 2-45
 - user profiles 2-45
- SNA distribution services (SNADS)**
 - coexistence 5-2
 - configuration 7-8
 - database file formats 2-47
 - definition G-5
 - distribution log 2-47
 - migration 7-3
 - objects 2-47
- SNA (Systems Network Architecture) G-6**
- SNA (Systems Network Architecture) environment, exchange ID 5-1**
- SNADS (SNA distribution services)**
 - coexistence 5-2
 - configuration 7-8
 - database file formats 2-47
 - definition G-5
 - distribution log 2-47
 - migration 7-3
 - objects 2-47
- sort utility 2-64**
- source**
 - attribute 1-13, 2-47
 - files 2-47
 - multiple versions 6-3
 - saved and restored 1-12
 - syntax 1-13
- source entry utility (SEU)**
 - definition G-5
 - functions 1-13
 - product, support in command definition 2-3
 - prompting 1-7
 - scan 3-4
 - source type 2-2, 2-23
 - source, recreated 3-2
 - System/38 commands in System/38 environment 6-3
 - type 1-13
- source file G-5**
- source file member**
 - DSPFD TYPE(*MBRLIST) statement 1-12
 - type 1-12
- source system G-5**
- SPCAUT keyword 2-38**
- special authorities 2-38**
- spelling aid dictionary 2-47**
- spool**
 - defaults 2-39, 2-48, 2-49
 - definition G-5
 - file names 2-48, 2-52
 - job description 2-49
 - parameters 2-48, 4-14
- spool** (*continued*)
 - print file attributes 2-51
 - printer device 2-49
 - queue 2-48
 - user profile 2-48
- spool control authority G-5**
- SQL/400 (Structured Query Language/400) G-6**
- SSCP (system services control point) G-6**
 - definition G-6
- SST (system service tools) 2-44, 2-52**
- STRCBLDBG command A-28**
- Structured Query Language/400 (SQL/400) G-6**
- subsystem**
 - activity level 2-55
 - controlling subsystem 2-54
 - defaults 2-53
 - multiple subsystem approach 2-53
 - performance adjustment 2-53
 - QCTL subsystem 7-7
 - QGPL description objects 7-7
 - simple subsystem approach 2-53
 - user profile 2-54
- synchronous data link control (SDLC)**
 - definition G-6
- syntax**
 - differences 2-3
 - licensed programs 1-6
 - rules 1-6
 - unqualified name 5-5
 - (of a) valid comment 4-2
 - (of the) parameters 4-1
- system ASP (auxiliary storage pool)**
 - definition G-6
- system configuration**
 - auto start job 7-4
 - customized 7-3
 - devices 7-4
 - security setting 7-3
 - Total System Package 7-3
- system configuration list G-6**
- system distribution directory G-6**
- system reply list 2-55**
- system request 2-55**
- system service tools (SST) 2-44, 2-52**
- system services control point (SSCP) G-6**
- system support 2-56**
- system time G-6**
- system values**
 - changed 2-57
 - CHGSYSVAL command 7-3
 - date and time 2-58
 - default 2-57
 - device automatic configuration 2-56
 - migration 1-5, 7-4
 - no longer supported 2-57
 - not migrated 2-57
- Systems Network Architecture distribution services (SNADS)**

Systems Network Architecture distribution services

(SNADS) (*continued*)

definition G-6

Systems Network Architecture (SNA) G-6

System/36 environment G-6

System/38 commands

OS/400 new commands A-2—A-40

System/38 environment

approach example 1-14, 1-15

CL (control language) source in the OS/400

program 1-13

defined 1-5, 1-6

definition G-6

differences (or changes)

hardware 1-3

operational 1-1, 1-4

programming 1-4

licensed programs 2-35

source 1-13

verbs 4-1

vector symbol set (VSS) G-6

VSS (vector symbol set) G-6

W

work management 2-60, 4-15

work station 2-60, G-6

work station user profile G-6

WRKJOB command 4-16

X

X.25 parameter

definition G-6

Special Characters

***EXCLUDE keyword 2-42**

***PUBLIC keyword 2-41**

***SIGNOFF keyword 2-46**

***SPLCTL keyword 2-38**

T

table 2-58

tape

devices 2-35, 2-58

SAVSYS command 1-3

target system

definition G-6

temporary library

definition G-6

test 2-59

text management 1-4, 2-65

TOFILE parameter

values A-8

TRNRND keyword B-1

TRNTBL keyword B-1

U

uninterruptible power supply

definition G-6

user ASP (auxiliary storage pool) G-6

user profile

authorities 2-40

authority 2-40

considerations 3-3

definition G-6

migration 2-37

printer, specify 2-48

QPGMR 2-54

sign-on 2-45

V

vary

cascading 2-10

DSPDEVCFG command 2-10

VRYCFG command 2-10



Fold and Tape

Please do not staple

Fold and Tape



NO POSTAGE
NECESSARY
IF MAILED IN THE
UNITED STATES



BUSINESS REPLY MAIL

FIRST CLASS MAIL PERMIT NO. 40 ARMONK, NEW YORK

POSTAGE WILL BE PAID BY ADDRESSEE

ATTN DEPT 245
IBM CORPORATION
3605 HWY 52 N
ROCHESTER MN 55901-7899



Fold and Tape

Please do not staple

Fold and Tape



Program Number: 5738-SS1

PRINTED IN DENMARK BY VANG RASMUSSEN LTD.

SC41-9755-00

